

Standard Bidding Document

REPAIR RENOVATION AND REFURBISHMENT OF ADMIN BLOCK,
MEDICAL CENTER, PARADE GROUND, SPORTS COMPLEX,
SWIMMING POOL & EXAMINATION HALL AT PAKISTAN MARINE
ACADEMY
(Works)

National

Single Stage-Two Envelope



May 17, 2026

*PNSC (CSR), Actg. General Manager Finance
FINANCE DEPARTMENT, 12TH FLOOR, PNSC BUILDING, M.T KHAN ROAD, KARACHI
Phone: +92-333-326-2196, Email: shoais.pervaiz@pns.com.pk*

Table of Contents

Instructions to Bidders	3
Bid Data Sheet	31
Bids Data Sheet (BDS)	32
Eligibility Criteria	36
Evaluation Criteria	37
Jobs/Lots	40
Related Services :	41
Work Specifications and Market Rates	41
Scope of Work	65
SCOPE OF WORKS	65
TECHNICAL SPECIFICATIONS	65
Price Schedule	67
General Conditions of Contract	69
Special Conditions of Contract	79
Bid Securing Declaration	85
Contract Form	87
Integrity Pact	90
Performance Guarantee Form	92
Annexure	94
Drawings	95
Technical Specification	95

BOQ of Works	95
Procurement Forms	96
Past Experience and Completed Contracts	1
Historical Contract Non-Performance, and Pending Litigation and Litigation History	1
Current Contracts and Their Progress	1
Financial Capacity and Net Worth Evaluation Form	1
Average Annual Turnover	1
Additional Forms and Documents	99

REQUEST FOR BIDS
PROCUREMENT OF CIVIL WORKS

1. The **PNSC (CSR)** has reserved Funds for the procurement planned for FY **2025-26**. The **PNSC (CSR)** intends to apply part of the proceeds of this Fund to cover eligible payments under the contract for the "**REPAIR RENOVATION AND REFURBISHMENT OF ADMIN BLOCK, MEDICAL CENTER, PARADE GROUND, SPORTS COMPLEX, SWIMMING POOL & EXAMINATION HALL AT PAKISTAN MARINE ACADEMY**".
2. The **PNSC (CSR)** invites sealed Bids from eligible Bidders for procurement of Works (**REPAIR RENOVATION AND REFURBISHMENT OF ADMIN BLOCK, MEDICAL CENTER, PARADE GROUND, SPORTS COMPLEX, SWIMMING POOL & EXAMINATION HALL AT PAKISTAN MARINE ACADEMY**) described in the bidding documents on **EPADS v2.0**.
3. **Single Stage-Two Envelope** will be used by adopting **Least Cost Based Selection (LCBS)** Technique for the subject procurement, in line with the Public Procurement Rules, 2004 and any Regulations, Regulatory Guides, Procurement Guidelines or Instructions issued by the Authority from time to time.
4. All Bids must be accompanied by a Bid Security amounting described in Bid Security Section in Bidding Document in the form of **Pay Order, Bank Guarantee**. Or all bids must be accompanied by bid securing declaration in the format specified in the Bidding documents
5. E-Bidding documents, containing detailed terms & conditions, specifications and requirements etc. are available on **e-Pak Acquisition and Disposal System (EPADS)** at <https://vendors.epads.gov.pk/> for all the interested bidders registered on **EPADS v2.0**. Bidders are required to get themselves registered on **EPADS v2.0** to participate in Bidding process.
6. The e-bids, prepared in accordance with the instructions in the e-Bidding documents, must be submitted through **EPADS v2.0** on or before **Monday, June 8, 2026 11:00 AM**. E-bids will be opened by using **EPADS v2.0** on the same day at **Monday, June 8, 2026 11:30 AM**. Manual submission of Bids shall not be entertained. Those vendor who have not yet registered on the new version of **EPADS v2.0**, may register themselves on

<https://pa.epads.gov.pk/>. A tutorial to explain the registration process is available at <https://www.youtube.com/watch?v=MNW6T38v7tc>.

In terms of Rules 48 of Public Procurement Rules, 2004 Grievance Redressal Committee (GRC) is notified for the subject procurement and notification copy is available on the procuring agency's website and on Authority's website at (www.ppra.org.pk).

PNSC (CSR), Actg. General Manager Finance
FINANCE DEPARTMENT, 12TH FLOOR, PNSC BUILDING, M.T KHAN ROAD,
KARACHI
+92-333-326-2196
shoais.pervaiz@pns.com.pk



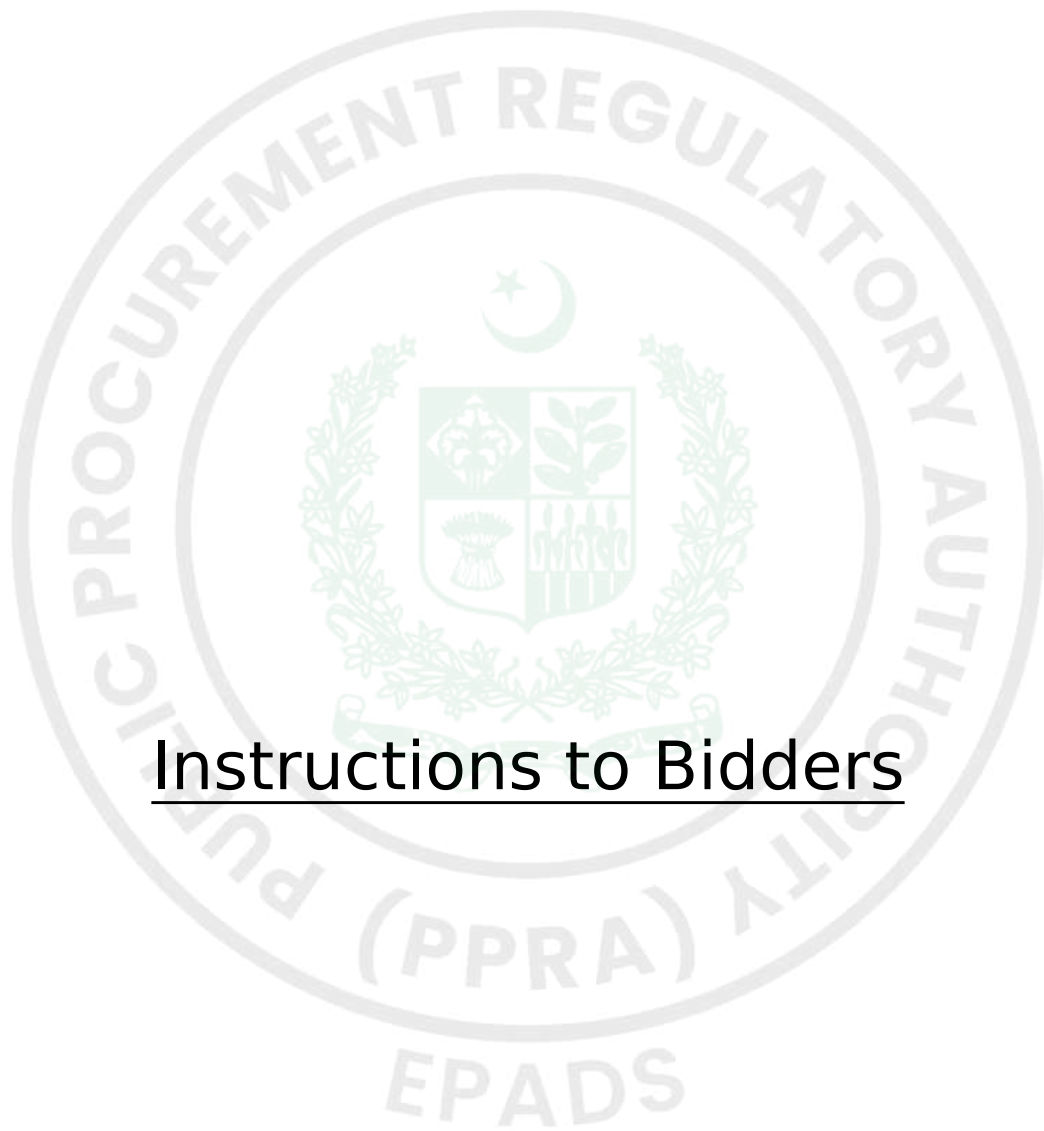

Instructions to Bidders

A. INTRODUCTION

1. Scope of Bid

1.1. The Procuring agency/Employer (PA), as indicated in the Bid Data Sheet (BDS) invites Bids for the execution of Works as specified in the BDS and Section V- Works Requirements. The name, identification, and number of lots (contracts) of this National/ International Competitive Bidding process are specified in the BDS.

2. Source of Funds

2.1. Source of funds as referred in Clause 2 of Bid Data Sheet.

3. Eligible Bidders

3.1. A bidder may be natural person, company or firm or public or semi-public agency of Pakistan or any foreign country, or any combination of them with a formal existing agreement (on Judicial Papers) in the form of a joint venture or consortium. In the case of a joint venture or consortium, all members shall be jointly and severally liable for the execution of the Contract in accordance with the terms and conditions of the Contract. The joint venture or consortium shall nominate a Lead Member as nominated in the BDS, who shall have the authority to conduct all business for and on behalf of any and all the members of the joint venture or consortium during the Bidding process, and in case of award of contract, during the execution of contract. Verifiable copy of the agreement that forms a joint venture, consortium or association shall be required to be submitted as part of the Bid.

Any bid submitted by the joint venture, consortium or association shall indicate the part of proposed contract to be performed by each party and each party shall be evaluated (or post qualified if required) with respect to its contribution only, and the responsibilities of each party shall not be substantially altered without prior written approval of the Procuring Agency and in line with any instructions issued by the Authority.

(The limit on the number of members of JV or Consortium may be prescribed

in BDS, in accordance with the guidelines issued by the PPRA).

3.2. The invitation for bids is open to all prospective bidders subject to any provisions of incorporation or licensing by the respective national/international incorporating agency or statutory body established for that particular trade or business. Procuring agencies shall specify the registration/licensing requirements for the foreign bidder keeping in view the requirement of that business.

3.3. A Bidder shall not have a conflict of interest. All Bidders found to have a conflict of interest shall be disqualified. A Bidders may be considered to have a conflict of interest with one or more parties in this Bidding process, if they:

3.3.1. are associated or have been associated in the past, directly or indirectly with a firm or any of its affiliates which have been engaged by the Procuring agency/Employer to provide consulting services for the preparation of design or technical specifications of the works that are the subject of the bid; or

3.3.2. have controlling shareholders in common; or

3.3.3. receive or have received any direct or indirect subsidy from any of them; or

3.3.4. have the same legal representative for purposes of this Bid; or

3.3.5. have a relationship with each other, directly or through common third parties, that puts them in a position to have access to information about or influence on the bid of another bidder, or influence the decisions of the Procuring agency/Employer regarding this Bidding process; or

3.3.6. Submit more than one bid in this bidding process.

3.4. A Bidder may be ineligible if -

3.4.1. he is declared bankrupt or, in the case of company or firm, insolvent;

3.4.2. payments in favor of the bidder is suspended in accordance with the judgment of a court of law other than a judgment declaring bankruptcy and resulting (in accordance with the national laws) in the total or partial loss of the right to administer and dispose of its property;

3.4.3. the bidder is convicted, by a final judgment of a Court of Law or relevant Professional Statuary Body, of any offence involving professional conduct;

3.4.4. The bidder is debarred/ blacklisted by a national level Procuring agency/Employer and hence debarred due to involvement in corrupt and fraudulent practices, or performance failure or due to breach of bid securing declaration.

3.5. As and when required, bidders shall provide to the Procuring agency/Employer evidence of their eligibility, proof of compliance with the necessary legal requirements to carry out the contract effectively.

3.6. Bidders shall submit proposal relating to the nature, conditions and modalities of sub-contracting wherever the sub-contracting of any elements of the contract is envisaged.

4. Eligible Material and Equipment

4.1. All the material and equipment to be mobilized under the contract shall have their origin in eligible source countries, and all expenditures made under the contract will be limited to such materials and equipment. For this purpose, ineligible countries are stated in the section-IV titled as "Eligible Countries".

B. BIDDING DOCUMENTS

1. Contents of Bidding Documents

1.1. The scope of Works, bidding procedures, and terms and conditions of the contract are prescribed in the bidding documents. In addition to the Invitation for Bids, the bidding documents which should be read in

conjunction with any addenda issued in accordance with ITB 7.1 include:

- Section I -Invitation for Bids
- Section II Instructions to Bidders (ITBs)
- Section III Bid Data Sheet (BDS)
- Section IV Eligible Countries
- Section V Evaluation and Qualification Criteria
- Section VI Works Requirements Technical Specifications & Schedule of Requirements
- Section VII Standard Bidding Forms
- Section VIII General Conditions of Contract (GCC)
- Section IX Particular Conditions of Contract (PCC)
- Section X Contract Forms

1.2. The bidder is expected to examine all instructions, forms, specifications, terms and conditions prescribed in the bidding documents. Failure to furnish all the information required in the bidding documents will be at the bidder's risk and may result in the rejection of his bid.

2. Clarification of Bidding Document, Pre-bid Meeting

2.1. A prospective bidder requiring any clarification of the bidding document may notify the Procuring agency/Employer through EPADS.

2.2. The Procuring agency/Employer shall respond to the request for clarification in accordance with Rule 31 of the Public Procurement Rules 2004.

2.3. Should the Procuring Agency deem it necessary to amend the BIDDING document as a result of a clarification, it shall do so following the procedure under ITB 7.

2.4. If indicated in the BDS, the bidder's designated representative is invited at the bidder's cost to attend a pre-bid meeting at the place, date and time mentioned in the BDS. During this pre-bid meeting, prospective bidders may request clarification of the schedule of requirement, the evaluation criteria or any other aspects of the bidding documents.

2.5. Minutes of the pre-bid meeting, if applicable, including the text of the questions asked by bidders, including those during the meeting (without identifying the source) and the responses given, together with any responses prepared after the meeting will be uploaded on EPADS. Any modification to the bidding documents that may become necessary as a result of the pre-bid meeting shall be made by the Procuring agency/Employer exclusively through the use of an Addendum pursuant to ITB 7. Non-attendance at the pre-bid meeting will not be a cause for disqualification of a bidder.

2.6. The bidder is advised to visit and examine the Site of Works and its surroundings and obtain for itself on its own responsibility all information that may be necessary for preparing the bid and entering into a contract for construction of the Works. The costs of visiting the Site shall be at the bidder's own expense.

2.7. The bidder and any of its authorized personnel will be granted permission by the Procuring agency/Employer to enter upon its premises and lands for the purpose of such visit, but only upon the express condition that the bidder and its personnel will release and indemnify the Procuring agency/Employer from and against all liability in respect thereof, and will be responsible for death or personal injury, loss or damage to property, and any other loss, damage, costs, and expenses incurred as a result of the inspection.

3. Amendment of Bidding Documents

3.1. The procuring agency may issue notification of any change, addition, modification or deletion in accordance with Rule 23 of the Public Procurement Rules 2004 i.e. Bidding Documents.

3.2. To give prospective bidders reasonable time in which to take an addendum/corrigendum into account in preparing their bids, the Procuring agency/Employer may, at its discretion, extend the deadline for the submission of bids:

Provided that the Procuring agency/Employer shall extend the deadline for submission of bid in pursuance of Rule 27 of the Public Procurement Rules 2004, i.e. Extension of time for submission of bids, if such an addendum is

issued within last three (03) days of the bid submission deadline.

C. PREPARATION OF BIDS

1. Language of Bid

1.1. The bid prepared by the bidder, as well as all correspondence and documents relating to the bid exchanged by the bidder and the Procuring agency/Employer shall be written in the English language unless specified in the BDS. Supporting documents and printed literature furnished by the bidder may be in another language provided they are accompanied by an accurate translation of the relevant pages in the English language unless specified in the BDS, in which case, for purposes of interpretation of the bidder, the translation shall govern.

2. Documents Constituting the Bids

2.1. The Bids prepared by the Bidder shall constitute of all the documents required in the BDS.

3. Documents Establishing Eligibility of Material, Equipment and Works, their Conformity to Bidding Documents

3.1. The bid prepared by the bidder shall constitute the following components: -

3.1.1. Documentary evidence established in accordance with ITB 10 that the material and equipment to be utilized by the Bidder for the executions of works are eligible material and equipment and conform to the Bidding Documents;

3.1.2. Documentary evidence established in accordance with ITB 11 that the bidder has been authorized to carry out the Construction works;

3.1.3. Documentary evidence established in accordance with ITB 11 that the bidder is eligible and/or qualified for the subject bidding process;

3.1.4. Form of Bid and Bid Prices completed in accordance with ITB 12 and 13;

3.1.5. Completed schedules as required, including priced Bill of Quantities in accordance with ITB 13.

3.1.6. Technical Proposal completed in all aspects in accordance with ITB-15.

3.1.7. Bid security or Bid Securing Declaration furnished in accordance with ITB 17;

3.1.8. Any other document required in the BDS.

3.2. In addition to the requirements, bids submitted by a JV shall include a copy of the Joint Venture Agreement entered into by all members. Alternatively, a letter of intent to execute a Joint Venture Agreement in the event of a successful bid shall be signed by all members and submitted with the bid, together with a copy of the proposed Agreement.

3.3. The bidder shall furnish, as part of its bid, all those documents establishing the eligibility in conformity to the terms and conditions specified in the bidding documents for all material, equipment and works which the bidder proposes to execute.

3.4. The documentary evidence of conformity of the material, equipment and works to the Bidding Documents may be in the form of literature, drawings, and data, and shall consist of:

3.4.1. a detailed description of the work methodology, approach, schedule and resources to be mobilized at site;

3.4.2. an item-by-item commentary on the Procuring agency/Employer's Technical Specifications demonstrating substantial responsiveness of the material, equipment and works to those specifications, or a statement of deviations and exceptions to the provisions of the Technical Specifications;

3.4.3. any other procurement specific documentation requirement as stated in the BDS.

3.5. The required documents and other accompanying documents must be in English. In case any other language than English is used the pertinent translation into English shall be attached to the original version.

4. Documents Establishing Eligibility and Qualification of the Bidder

4.1. The bidder shall furnish, as part of its bid, all those documents establishing the bidder's eligibility to participate in the bidding process and/or its qualification to perform the contract if its bid is accepted.

4.2. The documentary evidence of the bidder's eligibility to bid shall establish to the satisfaction of the Procuring agency/Employer that the bidder, at the time of submission of its bid, is from an eligible country as defined in Section-IV titled as "Eligible Countries".

4.3. The documentary evidence of the bidder's qualification to perform the contract if its bid is accepted shall establish to the satisfaction of Procuring agency/Employer that:

4.3.1. The bidder has the financial and technical capability necessary to perform the Contract, meets the qualification criteria specified in Section-V, Evaluation and Qualification Criteria and BDS.

4.3.2. In the case of a bidder not doing business within Pakistan, the bidder is or will be (if awarded the contract) represented by a local bidder (Joint Venture) in accordance with the PEC works bylaws, and in case of award of works such foreign firm is required to participate in the execution of works to carry out its obligations as prescribed in the Conditions of Contract and /or Technical Specifications.

4.3.3. That the bidder meets the qualification criteria listed in Section-V, Evaluation and Qualification Criteria and BDS.

5. Forms of Bid

5.1. The Bidder shall fill the Form of Bids furnished in the bidding documents. The Bids Form must be completed without any alterations to its format and no substitute shall be accepted.

6. Bid Prices

6.1. The bid prices quoted by the bidder in the Standard bid Forms, Bill of Quantities and in the Price Schedules shall conform to the requirements specified below or exclusively mentioned hereafter in the bidding documents.

6.2. The bidder shall fill in rates and prices for all items of the Works described in the Bill of Quantities. If a Price Schedule shows items listed but not priced, their prices shall be construed to be included in the prices of other items in the Bill of Quantities and will not be paid for separately by the Procuring agency/Employer.

6.3. Items not listed in the Price Schedule shall be assumed not to be included in the bid, and provided that the bid is still substantially responsive in their absence or due to their nominal nature, the corresponding average price of the respective item(s) of the remaining substantially responsive bidder(s) shall be construed to be the price of those missing item(s):

Provided that:

6.3.1. where there is only one (substantially) responsive bidder, or

6.3.2. where there is provision for alternate proposals and the respective items are not listed in the other bids,

The Procuring agency/Employer may fix the price of missing items in accordance with market survey, and the same shall be considered as final price.

6.4. The Bid price to be quoted in the Form of Bid in accordance with ITB 12 shall be the total price of the bid.

6.5. Unless otherwise specified in the BDS and the Contract, the rates and prices quoted by the bidder are subject to adjustment during the performance of the Contract in accordance with the provisions of the

Conditions of Contract.

6.6. If so specified in ITB 1.1, bids may be invited for individual lots (contracts) or for any combination of lots (packages).

6.7. Prices quoted by the Bidder shall be fixed during the bidder's performance of the contract and not subject to variation on any account. A bid submitted with an adjustable price will be treated as non-responsive and shall be rejected, pursuant to ITB 27, unless otherwise price adjustment is permissible under Conditions of the Contract.

6.8. All duties, taxes, and other levies payable by the Contractor under the Contract, or for any other cause, as of the date twenty-eight (28) days prior to the deadline for submission of bids, shall be included in the rates and prices and the total bid price submitted by the bidder.

7. Currencies of Bid and Payment

7.1. Prices shall be quoted in Pakistani Rupees unless otherwise specified in the BDS. Comparison of bids and tie of bid shall be treated in accordance with the Rule 30(2) of Public Procurement Rules, 2004.

8. Documents Comprising the Technical Proposal

8.1. The bidder shall furnish a Technical Proposal including a statement of work methods, equipment, personnel, schedule and any other information as stipulated in Section VII - Standard Bid Forms, in sufficient detail to demonstrate the adequacy of the bidder's proposal to meet the work requirements and the completion time.

9. Bid Validity Period

9.1. Bids shall remain valid for the period specified in the BDS after the bid submission deadline prescribed by the Procuring agency/Employer. A bid valid for a shorter period shall be rejected by the Procuring agency/Employer as non-responsive. The period of bid validity will be determined from the complementary bid securing instrument i.e. the expiry period of bid security or bid securing declaration as the case may be.

9.2. Under exceptional circumstances, prior to the expiration of the initial Bids/Bid validity period, the Procuring Agency may request the Bidders' consent to an extension of the period of validity of their Bids/Bid. Such request for extension of the period of bid validity shall be carried out in accordance with Rule 26 of the Public Procurement Rules, 2004.

10. Bid Security or Bid Securing Declaration

10.1. Pursuant to ITB 11.1 unless otherwise specified in the BDS, the bidder shall furnish as part of its bid, a Bid Security in accordance with Rule 25 of the Public Procurement Rules, 2004 in the amount and currency specified in the BDS or Bid Securing Declaration as specified in the BDS in the format provided in Section VII (Standard Bidding Forms).

In case Procuring agency/Employer is inviting bids in lots / packages, the bidder shall be required to submit his bid security against the respective lot/package for which he is submitting his bid.

Until the development of functionality of auto verification of financial instrument in EPADS, the scanned copy of bid security or bid securing declaration, as the case may be, shall be uploaded on E-PADS whereas the original instrument to be submitted to the procuring agency before closing of bid submission deadline,

10.2. The Bid Security shall be denominated in the local currency or in another freely convertible currency, and it shall be in the form specified in the **BDS** which shall be in any of the following:

10.2.1. A bank guarantee, an irrevocable letter of credit issued by a Scheduled bank in the form provided in the Bidding Documents or another form acceptable to the Procuring agency/Employer and valid for twenty-eight (28) days beyond the end of the validity of the Bid. This shall also apply if the period for Bid Validity is extended. In either case, the form must include the complete name of the bidder;

10.2.2. A cashier's or certified cheque; or

10.2.3. Another security as indicated in the **BDS**.

10.3. The Bid Security or Bid Securing Declaration shall be in accordance with the Form of the Bid Security or Bid Securing Declaration included in Section VII (Standard Bidding Forms) or another form approved by the Procuring agency/Employer prior to the bid submission.

10.4. The Bid Security shall be payable promptly upon written demand by the Procuring agency/Employer in case any of the conditions listed in ITB 17.9 are invoked.

10.5. Any bid not accompanied by a Bid Security or Bid Securing Declaration in accordance with ITB 17.1 or 17.3 shall be rejected by the Procuring agency/Employer and shall be declared as non-responsive bid, pursuant to ITB 27.

10.6. Unsuccessful bidders' Bid Security will be discharged or returned as promptly as possible, however in no case later than thirty (30) days after the expiration of the period of Bid Validity prescribed by the Procuring agency/Employer pursuant to ITB 16. The Procuring agency/Employer shall make no claim to the amount of the Bid Security, and shall promptly return the Bid Security document, after whichever of the following that occurs earliest:

10.6.1. The expiry of the Bid Security;

10.6.2. The entry into force of a procurement contract and the provision of a performance security (or guarantee), for the performance of the contract if such a security (or guarantee), is required by the Bidding documents;

10.6.3. The rejection by the Procuring agency/Employer of all Bids;

10.6.4. The withdrawal of the bid prior to the deadline for the submission of bids, unless the bidding documents stipulate that no such withdrawal is permitted.

10.7. The successful bidder's Bid Security will be discharged upon the bidder signing the contract pursuant to ITB 40, or furnishing the performance security (or guarantee), pursuant to ITB 41.

10.8. The Bid Security may be forfeited or the Bid Securing Declaration executed:

10.8.1. if a Bidder:

10.8.1.1. Withdraws its Bid during the period of Bid Validity as specified by the Procuring agency/Employer, and referred by the bidder on the Form of Bid except as provided for in ITB 16.2; or

10.8.2. In the case of a successful bidder, if the bidder fails:

10.8.2.1. to sign the contract in accordance with ITB 40; or

10.8.2.2. to furnish performance security (or guarantee) in accordance with ITB 41.

10.9. In case of Bid Security issued by the foreign bank is allowed by the Procuring agency/Employer, the same should be counter guaranteed by a corresponding bank in Pakistan. Furthermore, in case of joint venture, it should be in the name of Joint venture to ensure joint responsibility. In case the JV is not legally constituted at the time of bid submission, the bid security or bid securing declaration shall be in the names of all future members as named in the letter of bid.

11. Withdrawal of Bids

11.1. Before bid submission deadline, any bidder may withdraw, substitute, or modify its bid after it has been submitted by sending a written notice, duly signed by an authorized representative, and the corresponding must accompany the respective written notice.

12. Format and Signing of Bid

12.1. The Bidder shall prepare and submit Bids through EPADS with due diligence after carefully reading all the terms and condition before bid submission deadline.

D. SUBMISSION OF BIDS

1. **Submission of Bids through EPADS v2.0**

1.1. All bids shall be submitted through EPADS v2.0.

2. **Deadline for Submission of Bids**

2.1. All bids shall be received through **EPADS v2.0** not later than bid submission deadline as specified in the **BDS**.

2.2. The Procuring agency/Employer may, under exceptional circumstances and at its discretion, extend the deadline for the submission of bids, pursuant to Rule 27 of the Public Procurement Rules, 2004. Extension of Time for submission of bid, by amending the Bidding Documents in accordance with ITB 7, in which case all rights and obligations of the Procuring agency/Employer and bidders previously subject to the deadline will thereafter be subject to the new deadline.

3. **Substitution and Modification of bids**

3.1. A bidder may substitute or modify his bid after it has been submitted, provided that written notice of the substitution or modification of the bid, is received by the Procuring agency/Employer prior to the deadline for submission of bids.

3.2. Revised bid may be submitted after the substitution or modification made in the original bid in accordance with the provisions referred in **ITB 18**.

E. **OPENING AND EVALUATION OF BIDS**

1. **Opening of Bids**

1.1. The Procuring Agency will open bids in accordance with Rule 28 of the Public Procurement Rules, 2004 and as specified in the BDS.

2. **Confidentiality**

2.1. Information relating to the examination, clarification, evaluation and comparison of bids and recommendation of contract award shall not be disclosed to bidders or any other persons not officially concerned with such process until the time of the announcement of the respective evaluation report.

3. Clarification of Bids

3.1. Clarification of Bidding Documents shall be carried out in accordance with Rule 31 of the Public Procurement Rules, 2004.

3.2. The alteration or modification in the bid which in any case affect the following parameters will be considered as a change in the substance of a bid:

- 3.2.1. evaluation & qualification criteria;
- 3.2.2. required scope of work;
- 3.2.3. contract price;
- 3.2.4. all securities requirements;
- 3.2.5. tax requirements;
- 3.2.6. terms and conditions of bidding documents.
- 3.2.7. change in the ranking of the bidder

4. Preliminary Examination of Bids

4.1. Prior to the detailed evaluation of bids, the Procuring agency/Employer will determine whether each bid:

- 4.1.1. meets the eligibility criteria defined in **ITB 3** and **ITB 4**;
- 4.1.2. has been prepared as per the format and contents defined by the Procuring agency/Employer in the bidding documents;
- 4.1.3. has been properly signed;

4.1.4. is accompanied by the required securities; and

4.1.5. is substantially responsive to the requirements of the bidding documents.

The Procuring agency/Employer's determination of a bid's substantial responsiveness will be based on the contents of the bid itself.

4.2. A substantially responsive Bid is one which conforms to all the terms, conditions, and specifications of the Bidding Documents, without material deviation or reservation. A material deviation or reservation is one that: -

4.2.1. affects in any substantial way the scope, quality, or performance of the Works;

4.2.2. limits in any substantial way, inconsistent with the bidding documents, the Procuring agency/Employer's rights or the bidders' obligations under the Contract; or

4.2.3. if rectified, would affect unfairly the competitive position of other bidders presenting substantially responsive bids.

4.3. The Procuring agency/Employer will confirm that the documents and information specified under ITB 9, 10 and 11 have been provided in the bid. If any of these documents or information is missing, or is not provided in accordance with the Instructions to Bidders, the bid shall be rejected.

4.4. The Procuring agency/Employer may waive-off any minor informality, nonconformity, or irregularity in a bid which does not constitute a material deviation, provided such waiver does not prejudice or affect the relative ranking of any Bidder.

Explanation: A minor informality, non-conformity or irregularity is one that is merely a matter of form and not of substance. It also pertains to some immaterial defect in a Bid or variation of a bid from the exact requirements of the invitation that can be corrected or waived without being prejudicial to other bidders. The defect or variation is immaterial when the effect on quantity, quality, or delivery is negligible when contrasted with the total cost or scope of the works. The Procuring agency/Employer either shall give the bidder an opportunity to cure any deficiency resulting from a minor

informality or irregularity in a bid or waive the deficiency, whichever is advantageous to the Procuring agency/Employer. Examples of minor informalities or irregularities include failure of a bidder to –

4.4.1. Submit the number of copies of signed bids required by the invitation;

4.4.2. Furnish required information concerning the number of its employees;

4.4.3. the firm submitting a bid has formally adopted or authorized, before the date set for opening of bids, the execution of documents by typewritten, printed, or stamped signature and submits evidence of such authorization and the bid carries such a signature.

4.5. Provided that a Technical Bid is substantially responsive, the Procuring agency/Employer may request the bidder to submit the necessary information or documentation, within a reasonable period of time, to rectify nonmaterial nonconformities or omissions in the Technical Bid related to documentation requirements. Requesting information or documentation on such nonconformities shall not be related to any such aspect of the technical Proposal linked with the ranking of the bidders. Failure of the bidder to comply with the request may result in the rejection of its bid.

4.6. Provided that a Technical Bid is substantially responsive, the Procuring agency/Employer shall rectify quantifiable nonmaterial nonconformities or omissions related to the Financial Proposal. To this effect, the Bid Price shall be adjusted, for comparison purposes only, to reflect the price of the missing or nonconforming item or component.

4.7. If a bid is not substantially responsive, it will be rejected by the Procuring agency/Employer and may not subsequently be evaluated for complete technical responsiveness.

5. Examination of Terms and Conditions; Technical Evaluation

5.1. The Procuring agency/Employer shall examine the bid to confirm that all terms and conditions specified in the **GCC** and the **PCC** have been accepted

by the bidder without any material deviation or reservation.

For this purpose:

“Deviation” means departure from the requirements specified in the Bidding Document.

“Reservation” means setting of limiting conditions or withholding from complete acceptance of the requirements specified in the Bidding Document.

5.2. The Procuring agency/Employer shall evaluate the technical aspects of the bid submitted in accordance with ITB 30, to confirm that all requirements specified in Section VI – Works Requirement, Technical Specifications of the Bidding Documents have been met without material deviation or reservation.

5.3. If after the examination of the terms and conditions and the technical evaluation, the Procuring agency/Employer determines that the bid is not substantially responsive in accordance with ITB 27, it shall reject the bid.

6. Correction of Arithmetic Errors

6.1. Bids determined to be substantially responsive will be checked for any arithmetic errors. Errors will be corrected as follows: -

6.1.1. if there is a discrepancy between unit prices and the sub-total price that is obtained by multiplying the unit price and quantity, the unit price shall prevail, and the sub-total price shall be corrected, unless in the opinion of the Procuring agency/Employer there is an obvious misplacement of the decimal point in the unit price, in which the total price as quoted shall govern and the unit price shall be corrected;

6.1.2. if there is an error in a total corresponding to the addition or subtraction of sub-totals, the sub-totals shall prevail, and the total shall be corrected; and

6.1.3. where there is a discrepancy between the amounts in figures and in words, the amount in words will govern.

6.1.4. Where there is discrepancy between grand total of price schedule and amount mentioned on the Form of Bid, the amount referred in Price Schedule shall be treated as correct subject to elimination of other errors.

6.2. The amount stated in the Bid will, be rectified by the Procuring agency/Employer in accordance with the above procedure for the correction of errors and, with, the concurrence of the bidder, shall be considered as binding upon the bidder. If the bidder does not accept the corrected amount, its bid shall be rejected after forfeiture of Bid Security or execution of the Bid Securing Declaration, as the case may be, in accordance with **ITB 41.3**.

7. Conversion to Single Currency

7.1. The unit rates and the prices shall be quoted by the bidder entirely in Pak rupees. A bidder expecting to incur expenditures in other currencies for inputs to the Works from outside the Procuring agency/Employer's country (referred to as the "Foreign Currency Requirements") shall indicate the same in the letter of bid-financial proposal. The proportion of the Bid Price (excluding Provisional Sums) needed by him for the payment of such Foreign Currency Requirements either (i) entirely in the currency of the Bidder's home country or, (ii) at the bidder's option, entirely in Pak rupees provided always that a bidder expecting to incur expenditures in a currency or currencies other than those stated in (i) and (ii) above for a portion of the foreign currency requirements, and wishing to be paid accordingly, shall indicate the respective portions in his bid. Comparison of bids quoted in different currencies and conversion of bids into a single currency shall be carried out in accordance with Rule 30(2) of the Public Procurement Rules, 2004.

8. Evaluation of Bids

8.1. The Procuring agency/Employer shall evaluate and compare only the bids determined to be substantially responsive, pursuant to **ITB 27**.

8.2. In evaluating the Technical Proposal of each Bid, the Procuring agency/Employer shall use the criteria and methodologies listed in the BDS

and in terms of works requirement. No other evaluation criteria or methodologies shall be permitted.

8.3. The Procuring agency/Employer's evaluation of a bid will take into account:

8.3.1. the bid price, excluding provisional sums and the provision, if any, for contingencies in the summary bill of quantities, but including day work items, where priced competitively;

8.3.2. converting the amount resulting from applying above, if relevant, to a single currency in accordance with ITB 29;

8.4. The estimated effect of the price adjustment provisions of the Conditions of Contract, applied over the period of execution of the Contract, shall not be taken into account in bid evaluation.

8.5. If these bidding documents allow bidders to quote separate prices for different lots, and the award to a single bidder of multiple lots, the methodology of evaluation to determine the lowest evaluated lot combinations in the Form of Bid, is specified in the **BDS**.

8.6. If the bid, which results in the Evaluated Bid Price (Successful Bid), is seriously unbalanced or front loaded in the opinion of the Employer, the Employer may require the Bidder to produce detailed price analyses for any or all items of the Bill of Quantities, to demonstrate the internal consistency of those prices with the construction methods and schedule proposed. After evaluation of the price analyses, taking into consideration the schedule of estimated Contract payments, the Employer may require that the amount of the performance security be increased at the expense of the Bidder to a level sufficient to protect the Employer against financial loss in the event of default of the successful Bidder under the Contract.

Explanation:

"Unbalanced" or "front-loaded" bids consist of deliberately submitting bids with artificially high prices or unit rates for the early stages of a construction project, offset by artificially low prices or unit rates for the later stages of the project, to improve the contractor's cash flow.

9. Domestic Preference

9.1. If the **BDS** so specifies, the Procuring agency/Employer will grant a margin of preference to the domestic contractor in line with the rules, regulations, regulatory guides or instructions issued by the Authority from time to time.

10. **Determination of Successful Bid**

10.1. The Procuring agency/Employer shall compare the evaluated bids in accordance with the predefined bidding procedure, of all substantially responsive bids to determine the Successful bidder.

11. **Qualification of Bidder**

11.1. The Procuring agency/Employer shall determine to its satisfaction whether the bidder is substantially responsive and whose bid is declared as Successful bid either continues to meet (if prequalification applies) or meets (if post-qualification applies) the qualifying criteria specified in Evaluation and Qualification Criteria.

Note: In case of international bidding, the parameters for incorporation or licensing within Pakistan may be fulfilled as part of post qualification.

11.2. The determination shall be based upon an examination of the documentary evidence of the bidder's qualifications submitted by the bidder, pursuant to **ITB 11**.

11.3. Prior to contract award, the Procuring agency/Employer will verify that the successful bidder (including each member of a JV) is not blacklisted/debarred. The Procuring agency/Employer will conduct the same verification for each sub-contractor proposed by the successful bidder.

12. **Sub-Contractors**

12.1. The bidder shall provide details regarding any specialized sub-contractor to the Procuring agency/Employer. In case change of sub-contractors, the bidder shall promptly notify the Procuring agency/Employer and obtain approval for replacement of sub-contractors.

12.2. Bidders may propose sub-contracting up to the percentage of total value of contracts or the volume of works as specified in the **BDS**.

13. **Abnormally Low Financial Bid**

13.1. A procuring Agency may reject abnormally low bids. The decision of the Procuring agency/Employer to reject a bid and reasons for the decision shall be recorded in the procurement proceedings and promptly communicated to the bidder concerned. Moreover, the Procuring agency/Employer shall not incur any liability solely by rejecting abnormally bid

Guidance for Procuring agency/Employer:

An abnormally low bid means, in the light of the Procuring agency/Employer's estimate and of all the bids submitted, the bid appears to be abnormally low by not providing a margin for normal levels of profit. In order to identify the Abnormally Low Bid (ALB) following approaches can be considered to minimize the scope of subjectivity:

13.1.1. Comparing the bid price with the cost estimate;

13.1.2. Comparing the bid price with the bids offered by other bidders submitting substantially responsive bids; and

13.1.3. Comparing the bid price with prices paid in similar contracts in the recent past either government- or development partner-funded.

13.2. The Procuring agency/Employer will determine to its satisfaction whether the bidder that is selected as having submitted the successful bid is qualified to perform the contract satisfactorily, in accordance with the criteria listed in **ITB 11**

13.3. The determination will take into account the bidder's financial and technical capabilities. It will be based upon an examination of the documentary evidence of the bidder's qualifications submitted by the bidder, pursuant to **ITB 11**, as well as such other information as the Procuring agency/Employer deems necessary and appropriate. Factors not included in these bidding documents shall not be used in the evaluation of the bidders' qualifications.

13.4. Procuring agency/Employer may seek “Certificate for Independent Price Determination” from the bidder and the results of reference checks may be used in determining award of contract.

Explanation: The Certificate shall be furnished by the bidder. The bidder shall certify that the price is determined keeping in view of all the essential aspects such as raw material, its processing, value addition, optimization of resources due to economy of scale, transportation, insurance and margin of profit etc.

13.5. An affirmative determination will be a prerequisite for award of the contract to the bidder. A negative determination will result in rejection of the bidder’s bid, in which event the Procuring agency/Employer will proceed to the next ranked bidder to make a similar determination of that bidder’s capabilities to perform satisfactorily.

F. AWARD OF CONTRACT

1. Criteria of Award

1.1. Subject to **ITB 36 and 37**, the Procuring agency/Employer will award the Contract to the bidder whose bid has been determined to be substantially responsive to the bidding documents and who has been declared as Successful Bidder, provided that such bidder has been determined to be:

1.1.1. eligible in accordance with the provisions of **ITB 3**;

1.1.2. is determined to be qualified to perform the Contract satisfactorily;
and

1.1.3. Successful negotiations have been concluded, if any.

2. Negotiations

2.1. The Committee of the Procuring agency/Employer may negotiate with the Most Advantageous Bidder relating to the following areas:

2.1.1. a minor alteration to the technical (drawings, design technical specifications) details of the statement of works;

2.1.2. Methodology, work plan, staffing in view to streamline the work;

2.1.3. a minor amendment to the Particular conditions of Contract;

2.1.4. finalizing payment arrangements;

2.1.5. clarifying details that were not apparent or could not be finalized at the time of Bidding;

2.2. Where negotiation fails to result into an agreement, the Procuring agency/Employer may invite the next ranked bidder for negotiations. Where negotiations are commenced with the next ranked bidder, the Procuring agency/Employer shall not reopen earlier negotiations.

3. Procuring agency's Right to reject All Bids

3.1. The procuring agency has the right to reject all bids in accordance with Rule 33 of the Public Procurement Rules, 2004. However, the Authority (i.e. **PPRA**) may call from the Procuring agency/Employer the justification of those grounds.

4. Notification of Award

4.1. The procuring agency shall announce and publish the evaluation result in accordance with Rule 35 of the Public Procurement Rules, 2004.

4.2. Where no complaints have been lodged, the bidder whose bid has been accepted will be notified of the award by the Procuring agency/Employer prior to expiration of the bid validity period through EPADS. However, the Procuring agency/Employer shall not award any procurement contract at least for five (05) days after the announcement of final evaluation report. The notification letter (herein after and in the condition of the contract and contract form called "Letter of Acceptance" will specify the sum that the Procuring agency/Employer will pay the successful bidder in consideration for the execution and completion of the works as prescribed by the Contract

(hereinafter and in the Contract called the "Contract Price).

4.3. The notification of award will constitute the formation of the Contract, subject to the bidder furnishing the Performance Security (or guarantee) in accordance with **ITB 41** and signing of the contract in accordance with **ITB 40**.

4.4. Upon the successful bidder's furnishing of the performance security (or guarantee) pursuant to **ITB 41**, the Procuring agency/Employer will promptly notify each unsuccessful bidder, the name of the successful bidder and the Contract amount and will discharge the Bid Security or Bid Securing Declaration of the bidder(s) pursuant to **ITB 17**.

5. Signing of Contract

5.1. Promptly after notification of award, Procuring agency/Employer shall send the successful bidder the draft agreement, incorporating all terms and conditions as agreed by the parties to the contract.

5.2. Immediately after the Redressal of grievance by the **GRC**, and after fulfillment of all conditions precedent of the Contract Form, the successful bidder and the Procuring agency/Employer shall sign the contract.

5.3. Where no formal signing of a contract is required, work order issued to the bidder shall be construed to be the contract.

6. Performance Security (or Guarantee)

6.1. After the receipt of the Letter of Acceptance, the successful bidder, within the specified time, shall deliver to the Procuring agency/Employer a Performance Guarantee in the amount and in the form stipulated in the BDS and PCC, denominated in the type and proportions of currencies in the Letter of Acceptance and in accordance with the Conditions of Contract.

6.2. If the Performance Guarantee is provided by the successful bidder and it shall be in the form specified in the BDS which shall be in any of the following:

6.2.1. certified cheque, cashier's or manager's cheque, or bank draft;

6.2.2. irrevocable letter of credit issued by a scheduled bank of Pakistan or in the case of an irrevocable letter of credit issued by a foreign bank, the letter shall be confirmed or authenticated by a scheduled bank of Pakistan;

6.2.3. bank guarantee confirmed by a reputable local bank or, in the case of a successful foreign bidder, bonded by a foreign bank; or

6.2.4. surety bond callable upon demand issued by any reputable surety or insurance company.

Any Performance Guarantee submitted shall be enforceable in Pakistan.

6.3. Failure of the Most Advantageous Bidder to comply with the requirement of **ITB 40** shall constitute sufficient grounds for the annulment of the award and forfeiture of the Bid Security or declare blacklisted (in case bid securing declaration is submitted) in which event the Procuring agency/Employer may make the award to the next most advantageous bidder or reinstate the procurement process afresh (as a case may be).

7. Advance Payment

7.1. Advance payment will be provided to the bidder in percentage and in the manner as agreed by the both parties in terms of Conditions of the Contract.

7.2. The Procuring agency/Employer will provide an advance payment as stipulated in the Conditions of Contract, subject to a maximum amount, as stated and/or Conditions of the Contract. The advance payment request shall be accompanied by an advance payment security (guarantee) in the form provided in Section X. For the purpose of receiving the advance payment, the bidder shall make and estimate of, and include in its bid, the expenses that will relate to the purchase of equipment, machinery, materials, and on the engagement of labor during the first month beginning with the date of the Procuring agency/Employer's "**Notice to Commence**" as specified in the **PCC**.

8. General Performance of the Bidders

8.1. The Procuring agency/Employer reserves the right to obtain information regarding performance of the bidders on their previously awarded contracts / works. The Procuring agency/Employer may seek information / report from the previous employer for consideration. However, the Procuring agency/Employer shall incorporate such parameters in the evaluation criteria and accordingly decide the fate of the bid submitted.

9. Corrupt & Fraudulent Practices

9.1. Procuring agencies (including beneficiaries of Government funded projects and procurement) as well as Bidders/Suppliers/Contractors under Government financed contracts, observe the highest standard of ethics during the procurement and execution of such contracts, and will avoid to engage in any corrupt and fraudulent practices.

G. GRIEVANCE REDRESSAL & COMPLAINT REVIEW MECHANISM

1. Grievance Redressal

1.1. Grievance Redressal shall be carried out in accordance with Rule 48 of the Public Procurement Rules, 2004 i.e. Redressal of grievances by the procuring agency and "Redressal of Grievances Regulations 2021".

H. MECHANISM OF BLACKLISTING

1. Mechanism of Blacklisting

1.1. The Procuring agency/Employer shall proceed Blacklisting of Bidders/Contractors in accordance with Rule 19 of the Public Procurement Rules, 2004 i.e. Blacklisting and "Blacklisting and Debarment of Bidders or Contractors Regulations 2024".

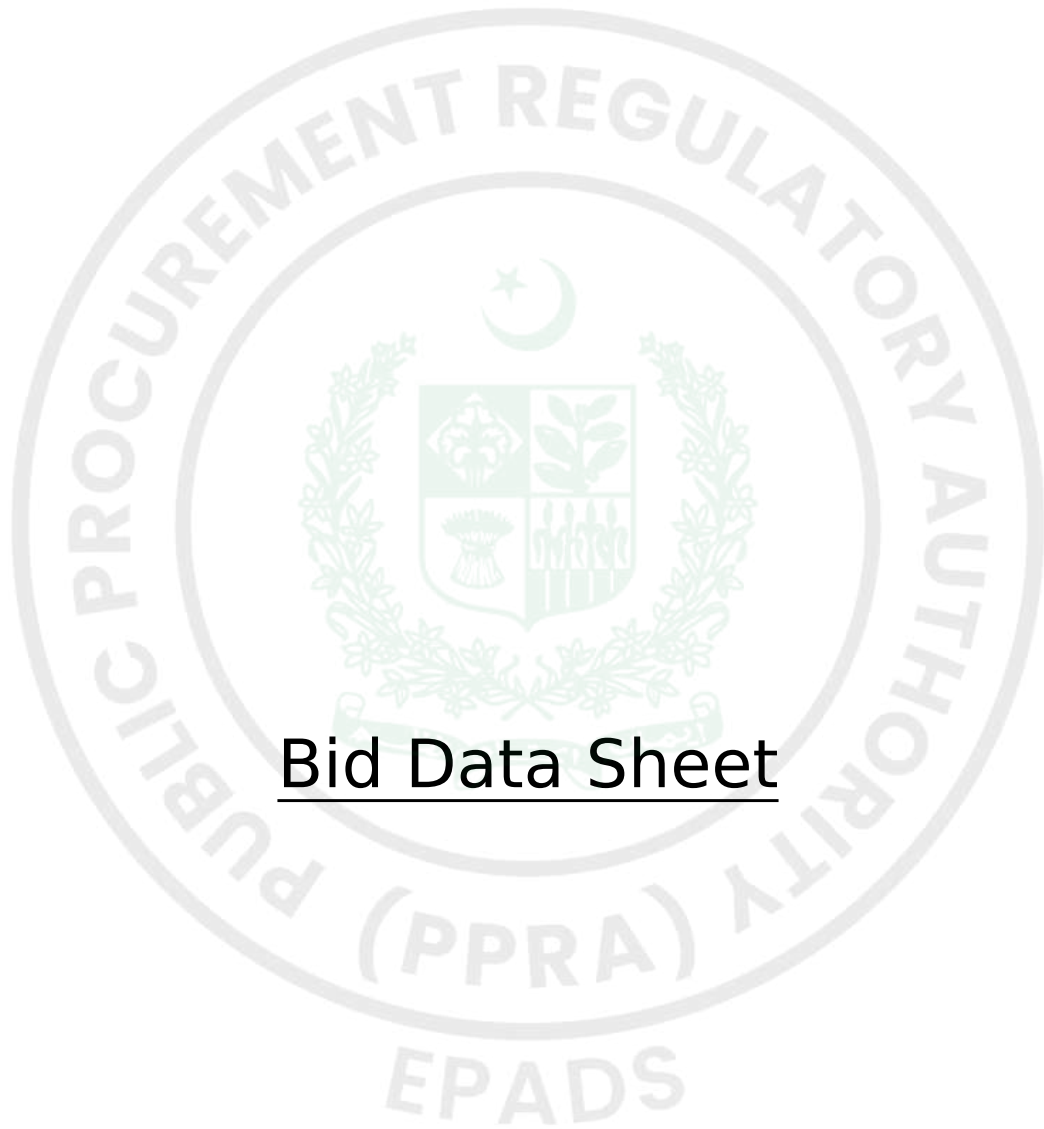

Bid Data Sheet

Bids Data Sheet (BDS)

The following specific data for the procurement of Goods to be procured shall complement, supplement, or amend the provisions in the Instructions to Bidders (ITB). Whenever there is a conflict, the provisions herein shall prevail over those in ITB.

BDS Clause Number	ITB Number	Amendments of, and Supplements to, Clauses in the Instruction to Bidders
A. Introduction		
1	1.1	<p>Name of Procuring Agency:PNSC (CSR)</p> <p>The subject of procurement is:REPAIR RENOVATION AND REFURBISHMENT OF ADMIN BLOCK, MEDICAL CENTER, PARADE GROUND, SPORTS COMPLEX, SWIMMING POOL & EXAMINATION HALL AT PAKISTAN MARINE ACADEMY</p> <p>Expected commencement date: Monday, July 20, 2026</p>
2.	2.1	<p>Financial year for the operations of the Procuring Agency:2025-26</p> <p>Name and identification number of the Contract: P36011</p>
3.	3.1	<p>JV/Consortium or Association Allowed: No</p> <p>Number of JV/Consortium Members: Nil</p>
B. Bidding Documents		

4.	6.2 & 6.4	The Bidders may seek clarifications through EPADS v2.0 : Clarification Date: Tuesday, June 2, 2026
5.	7.2	Any addendum, in case issued, shall be published on PNSC (CSR) website and on EPADS v2.0 .
C. Preparation of Bids		
6.	8.1	List of documents required along with the bid: No
7.	9.1	The qualification criteria to establish the supply / production capability of the bidder. <i>see Eligibility Criteria</i>
8.	11.2	Works and Their related documents: <i>See section Required Scope of Work</i>
9.	11.1	Price schedule will be provided according to the format defined and acquired. <i>see section price schedule.</i>
10.	11.4	Specifications: <i>see section of specifications.</i>
11.	11.5 & 13.5	The price shall be Fixed . The bid price shall be adjusted in accordance with Appendix provided - Formula for Price Adjustment.
12.	14.1	Currency of the Bids shall be : PKR

13.	16.1	The Bids/Bid Validity period shall be: 120 Days
14.	17.1	The amount of Bid Security shall be as defined in Bid Security Section for items and lots given in BDS 6
15.	17.2	The Bid Security shall be in the form of: Pay Order, Bank Guarantee
16.	15.1	Alternative Bids to the requirements of the bidding documents willnot be permitted.
D. Submission of Bids		
17.	18.1 & 21.1	<p>Bid shall be submitted online on EPADS v2.0 whereas hard copy of the bid security should be submitted to the following;</p> <p>FINANCE DEPARTMENT, 12TH FLOOR, PNSC BUILDING, M.T KHAN ROAD, KARACHI</p> <p>Bids that are not submitted on EPADS v2.0 shall be disqualified.</p> <p>The deadline for Bids submission is: Monday, June 8, 2026 11:00 AM</p>
E. Opening and Evaluation of Bids		
18.	24.1	<p>The Bids opening shall take place on EPADS v2.0.</p> <p>Day : Monday</p> <p>Date: June 08, 2026</p> <p>Time : 11:30 AM</p>

19.	30.2	Selection technique adopted will be: Least Cost Based Selection (LCBS) <i>see Evaluation Criteria</i>
F. Award of Contract		
20.	41.1 & 41.2	The Performance guarantee shall: 5.00% . The Performance Guarantee shall be acceptable in the form of: Pay Order, Bank Guarantee
21.	45.1	Arbitrator shall be appointed by mutual consent of the both parties.
G. Review of Procurement Decisions		
22.	37	Grievance against this procurement shall be submitted online on EPADS v2.0.

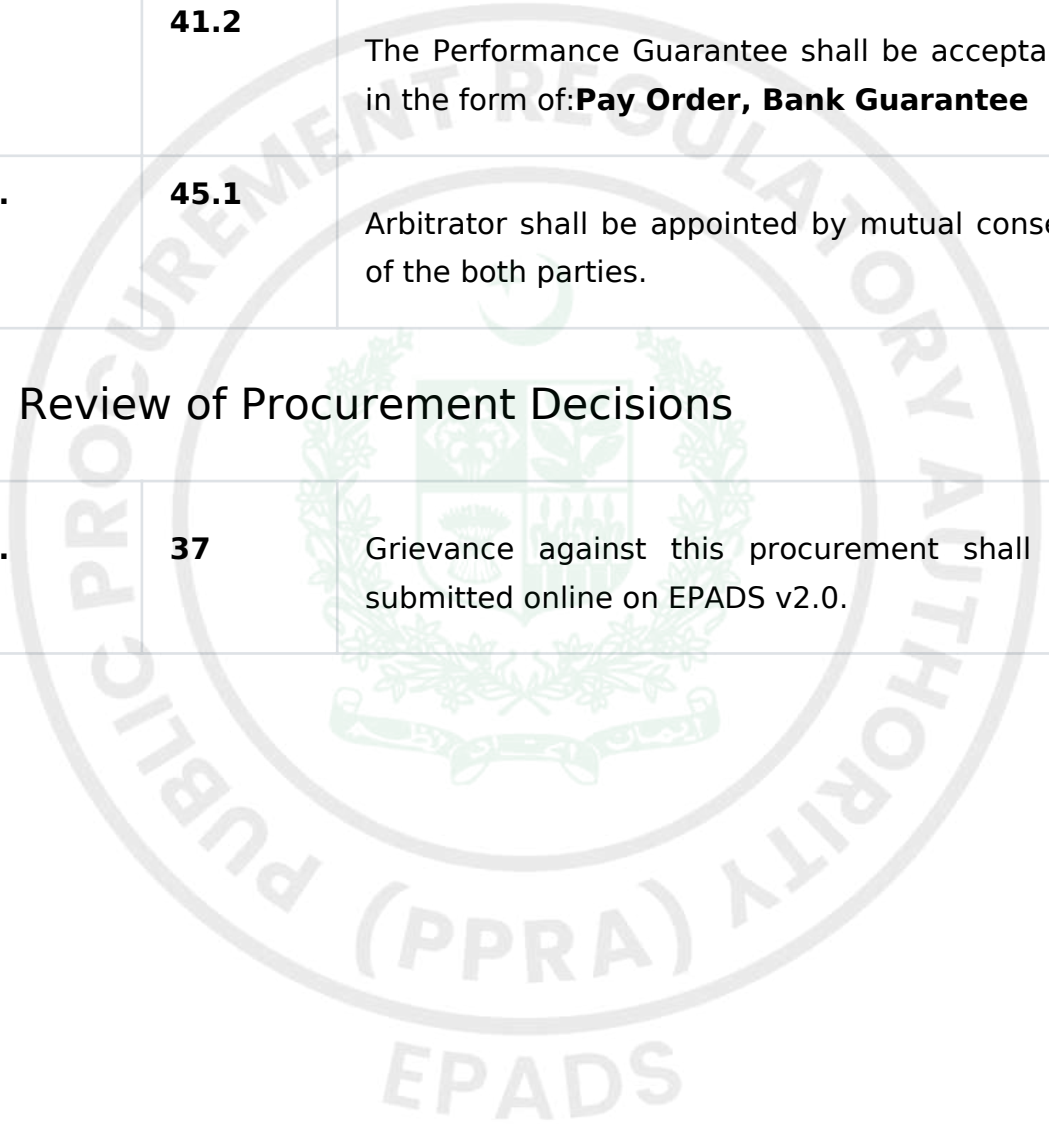

Eligibility Criteria

Bidder's Type	Required Registration
Individual / Individual Consultant Sole Proprietorship Partnership Firm Company (Private Limited) Company (Public Limited) Company (Holding Company) Company (Limited by Guarantee) State Owned Enterprise (Private Limited) State Owned Enterprise (Public Limited)	NADRA CITIZENSHIP (CNIC/NICOP) FBR (NTN) PEC

Eligibility Criteria	Document
Valid Pakistan Engineering Council (PEC) for the year 2026 in Category C-4 or above	Yes
Valid Sales Tax Certificate from Sales Tax Authorities (Sindh Revenue Board SRB).	Yes
The bidder/firms must be duly enlisted on the Active Taxpayer List (ATL) maintained by the Federal Board of Revenue, with an active status for Income Tax and an operative status for Sales Tax at the time of bid submission and throughout the procurement process.	Yes

<p>The bidder shall furnish an affidavit on a stamp paper of PKR 100/- duly notarized, affirming that the firm has not been blacklisted by any Procuring Agency, Government or Semi-Government Department, Autonomous Body, or International Organization operating in Pakistan. The bidder shall further declare that the firm has no history of litigation and has never engaged in any corrupt, fraudulent, collusive, or unethical practices. The bidder shall also undertake and certify that all information and</p>	<p>Yes</p>
--	------------

Evaluation Criteria

Least Cost Based Selection (LCBS)

<p>Technical Marks</p>	<p>100</p>
<p>Passing Marks</p>	<p>70</p>
<p>a. Work Experience</p>	
<p>i) Experience of Overall works of the firm as prime contractor (10 points for each project of Rs. 50 Million or above satisfactorily completed in last 12 years up to a maximum of 03 such projects). Documentary proof (i.e. work order & completion certificate) to be attached (Quantitative)(Doc Required)</p> <p>3 projects of Rs. 50 Million or above satisfactorily completed in last 12 years (30)</p> <p>2 projects of Rs. 50 Million or above satisfactorily completed in last 12 years (20)</p> <p>1 project of Rs. 50 Million or above satisfactorily completed in last 12 years (10)</p>	<p>30</p>

<p>ii) Experience of Similar/ Building of the firm as prime contractor (5 points for each project of Rs. 50 Million or above satisfactorily completed in last 05 years up to a maximum of 03 such projects). Documentary proof (i.e. work order & completion certificate) to be attached. (Quantitative)(Doc Required)</p> <p>3 projects of Rs. 50 Million or above satisfactorily completed in last 05 years (15)</p> <p>2 projects of Rs. 50 Million or above satisfactorily completed in last 05 years (10)</p> <p>1 project of Rs. 50 Million or above satisfactorily completed in last 05 years (5)</p>	15
<p>iii) Regional Experience of Similar/ Building works of the firm as prime contractor (5 points for each project of Rs. 50 Million or above satisfactorily completed in last 05 years up to a maximum of 03 such projects). Documentary proof (i.e. work order & completion certificate) to be attached. (Quantitative)(Doc Required)</p> <p>3 projects of Rs. 50 Million or above satisfactorily completed in last 05 years (15)</p> <p>2 projects of Rs. 50 Million or above satisfactorily completed in last 05 years (10)</p> <p>1 project of Rs. 50 Million or above satisfactorily completed in last 05 years (5)</p>	15
b. Personal Capability and Equipment	
<p>Project Manager (Must be a University Engineering Degree Holder in Civil) B.E./B.Sc. Civil or Master's Degree in Civil/ Construction Engineering (Quantitative)(Doc Required)</p>	1
<p>Project Manager Total Work Experience (Years) (Quantitative)(Doc Required)</p> <p>Total Work Experience (More Than 20 Years) (2)</p> <p>Total Work Experience (More Than 10 Years) (1)</p>	2

Project Manager Specific Work Experience (More than 10 Years) (Quantitative)(Doc Required)	1
Site Engineer (Must be a University Engineering Degree Holder in Civil) B.E. Civil (Quantitative)(Doc Required)	1
Site Engineer with Minimum Total experience of 4 years and Specific experience of 4 years (Quantitative)(Doc Required)	1
Lab Technician (At least holds Diploma of Associate Engineer in Civil) D.A.E. Civil with Total Work Experience of more than 4 Years and specific experience of 3 years (Quantitative)(Doc Required)	1
Quantity Surveyor (At least holds Diploma of Associate Engineer in Civil) with Total Work Experience of more than 4 Years and specific experience of 3 years (Quantitative)(Doc Required)	1
Surveyor (At least holds Diploma of Associate Engineer in Civil) with Total Work Experience of more than 4 Years and specific experience of 3 years (Quantitative)(Doc Required)	1
Site Supervisor (At least holds Diploma of Associate Engineer in Civil) with Total Work Experience of more than 4 Years and specific experience of 3 years (Quantitative)(Doc Required)	1
List of machinery and equipment intended to be used on the projects with proof of ownership. (Quantitative)(Doc Required)	5
c. Financial Position and Litigation History	
i. Audited Account Report for last 03 years (Quantitative)(Doc Required)	5

ii. Average Annual turnover of last 03 Years (to be ascertained from Audited Reports) (Quantitative)(Doc Required) More than Rs 400 M (15) Rs 260.1 M to Rs. 300 M (12) Rs 120.1 M to Rs. 260 M (9) Rs 80.1 M to Rs 120 M (6) Rs 40 M to Rs. 80 M (3)	15
iii. Banker’s certificate for financially soundness, issued in last 06 months, that the bidder has sufficient amount in particular. (Quantitative)(Doc Required)	5

Jobs/Lots

Jobs Without Lots :

Job	Delivery Schedule	Quantity	Bid Security
REPAIR RENOVATION AND REFURBISHMENT OF ADMIN BLOCK, MEDICAL CENTER, PARADE GROUND, SPORTS COMPLEX, SWIMMING POOL & EXAMINATION HALL AT PAKISTAN MARINE ACADEMY	Address: PAKISTAN MARINE ACADEMY Schedule: 160 Days Quantity: 1	1	2326397.4

Items Without Lots :

Item	UNSPSC	Delivery Schedule	Quantity	Bid Security	Related to Job/Lot
REPAIR RENOVATION AND REFURBISHMENT OF ADMIN BLOCK, MEDICAL CENTER, PARADE GROUND, SPORTS COMPLEX, SWIMMING POOL & EXAMINATION HALL AT PAKISTAN MARINE ACADEMY	Commercial and office building renovation and repair service	Address: PAKISTAN MARINE ACADEMY Schedule: 160 Days Quantity: 1	1	3	REPAIR RENOVATION AND REFURBISHMENT OF ADMIN BLOCK, MEDICAL CENTER, PARADE GROUND, SPORTS COMPLEX, SWIMMING POOL & EXAMINATION HALL AT PAKISTAN MARINE ACADEMY (Job)

Related Services :

No

Work Specifications and Market Rates

Jobs Without Lots :

Job: REPAIR RENOVATION AND REFURBISHMENT OF ADMIN BLOCK, MEDICAL CENTER, PARADE GROUND, SPORTS COMPLEX, SWIMMING POOL & EXAMINATION HALL AT PAKISTAN MARINE ACADEMY

Specifications / Requirements:

Sr. No	Ref. No.	Description	Unit	Qty	Rate	Amount
--------	----------	-------------	------	-----	------	--------

1	REWA/1	Dismantling R.C.C. including separating reinforcement from concrete including stacking at site and disposing of unserviceable material complete and as per instructions of Engineer in charge.	%Cft	9809	161.5	1,584,154
2	REWA/2	Dismantling Block masonry including disposing of surplus material and Providing & laying pre-cast solid blocks masonry using 6"x8"x12" size pre-cast blocks of min 1000 psi compressive strength set in cement mortar 1:5 in any floor superstructure including scaffolding, raking out joints & curing and plastering with 1/2" (13 mm) thick cement plaster 1:6 complete. complete and as per instructions of engineer in charge	%Cft	388	872.93	338,697
3	REWA/3	Clearing and grubbing the site by cutting, uprooting and removing all rubbish and shrubs including disposal to (outside limits) designated places.	%Sft	2291	1.8	4,124

4	REWA/4	Providing and laying Ready mix Reinforced concrete 4000 Psi cylindrical strength using stationary or any other pumps, as in roof, slabs, walls, landings, plinth beams,rafts and bands etc as specified requiring steel shuttering etc complete & as per instructions of engineer in charge. Reinforcement to be measured and paid separately.	%Cft	9291	891.4	8,281,997
5	REWA/5	Providing and laying deformed (minimum yield point 60,000 psi) reinforcement bars with & including the cost of straightening, cutting, bending, binding, placing in position in all kinds of RCC work in foundation, basement, plinth and any floor of building and as per direction of engineer in charge.	%Kg	16858	381.62	6,433,350
6	REWA/6	Providing loose concrete near the Corroded Exposed Rebars and adjacent to the corroded area, wire brushing of rebars,applying zinc Rich on Rebars,nailing the treated surface by concrete nails if 8 BWG, applying SBR all around the surface, placing 20 BWG Expanded Metal and laying with installed nails and plastering with 1:3 cement sand Mortar mixed with plasticizer and finishing the surface to fine and level the surrounding surface.	%Sft	948	2911.66	2,760,254

7	REWA/7	Rehabilitation of Columns By cutting the damaged surface and brushing of existing steel bars to remove the rust, and coating the bars with zinc rich primer to protect from rust, add new bars where required by drilling holes and filling the holes with chemical grout and concreting the column with 5000PSI Concrete as per drawings, site requirement and direction of engineer incharge.	%Sft	722	953.67	688,550
8	REWA/8	Rehabilitation of Plinth Beams by Cutting the damaged surface and brushing of existing steel bars to remove the rust, and coating the bars with zinch rich primer, excavate the area to add lean 1:2:4 below plinth beam, add new bars and concreting the beam with 5000 PSI concrete as per drawings, site requirement and direction of engineer incharge.	%Rft	42	3547.96	149,014
9	CPB/1	1/2" (13 mm) thick cement plaster 1:4 on walls and columns etc. making edges, comers, and curing etc., complete. (Internal Plaster)	%Sft	927	79.1	73,326
10	CPB/2	3/8" (10 mm) thick cement plaster 1:4 including making edges, corners, and curing etc. (Ceiling Plaster)	%Sft	11973	59.63	713,950

11	CPB/3	3/4" (19 mm) thick cement plaster 1:4 including making edges, corners, and curing etc. (External Plaster)	%Sft	4348	68.78	299,055
12	PC/1	Removal of old Paint and Painting three coats with weather shield paint (Each coat will be applied after 5 Days)	%Sft	5296	52.24	276,663
13	PC/2	Removal of old Paint and Distempering three coats with poly vinyl distemper (Each coat will be applied after 5 Days)	%Sft	11973	43.02	515,078
14	PC/3	Removal of old Paint and Preparing the surface and painting three coats with matt finish (Each coat will be applied after 5 Days)	%Sft	1843	56.76	104,609
15	PC/4	Providing and fixing angle section of L 6"x6"x1/4" for supporting of Existing Beam and making its connections with Rawal Bolts and using Welding work to attach Angle iron with another Angle iron	%Each	51	1624.45	82,847
16	FD/1	Providing & laying floor of mosaic marble chips tile 1" (25mm) thick of approved quality and shade laid in white cement and pigment over 3/4" (20mm) thick bedding in cement sand mortar 1:2 including finishing and polishing complete as per Approval of Client	%Sft	11510	222.88	2,565,349

17	FD/2	Laying floor of approved with glazed tiles 1/4" thick dado of approved color & size jointing in white cement and laid over 1:2 cement sand mortar 3/4" thick including grouting with matching color and finishing	%Sft	675	389.36	262,818
18	RTE/1	Providing water proofing roof treatment by Dismantling old Screeding and providing hot bitumen layer with Insulation Board and sand as slope after screeding provided for water drainage.	%Sft	11963	104.96	1,255,636
19	RTE/2	Providing and laying 3" thick topping of cement concrete (1:2:4) including Surface finishing and dividing into panels:	%Sft	11963	145	1,734,635
20	DWF/1	Providing and fixing Aluminium windows & Ventilator box section including the cost of glass pan, aluminium fittings, with all accessories cutting hole etc. and making good damages to walls etc. complete as required in any floor as per direction of engineer-in-charge	%Sft	558	1358.5	758,043
21	DWF/2	First Class deodar wood wrought joinery in doors and windows etc. panelled or panelled or glazed or fully glazed fixed in position including chowkhat, holdfast, hinges, tower bolt rubber stop cleats/G I clamp, handles and chord with hooks etc. complete (excluding sliding bolts or lock).	%Sft	460	3000	1,380,000

22	DWF/3	Supplying & fixing in position iron/steel grill of 3/4" x 1/4" size flat iron of approved design including painting 3 coats etc. complete (weight not to be less than 3.7 Lbs./Sq . Foot of finished grill)	%Sft	558	1125	627,750
23	PPG/1	Excavation for Plinth Protection about 1.5ft wide & 1.5ft Deep and Providing CC 1:4:8 Below Foundation with 6" Thick Block Masonry and laying 50mm Pavers, 2" Thick Sand Cushion,4" Thk Gravel Layer and 4" Thk 1:3:6 as Per Direction of Engineer-in-Charge.	%Rft	482	5617.82	2,707,789
24	PH/a/1	25mm 1" --PPRC pipe PN-20	%Rft	66	899.41	59,361
25	PH/b/1	50mm 2" --PPRC pipe PN-20	%Rft	20	3753.42	75,068
26	PH/c/1	1 inches (25mm) dia Ball Valve	%Each	2	212.26	425
27	PH/d/1	1-1/2 inches (40mm) dia Ball Valve	%Each	3	399.26	1,198
28	PH/e/1	2 inches (50mm) dia Ball Valve	%Each	2	652.26	1,305
29	PH/g/1	4 inches (100 mm) dia pipe. --(U.P.V.C) "E" class	%Rft	40	5354.32	214,173
30	PH/2	Supplying & fixing Fiber glass tank of approved quality and design and wall thickness as specified including cost of nuts, bolts and fixing in plat form of cement concrete 1:3:6 and making connection for inlet, outlet and over flow pipes etc. complete 350 gallons tank with wall thickness 4.0mm	%Each	2	50000	100,000

31	PH/3	Providing and fixing squatting type white glazed earthen ware W.C pan with front flush inlet & complete with including the cost of flushing cistern with internal fitting and flush pipe with bend and requisite number of holes in walls plinth & floor for pipe connection & making good in cement concrete 1:2:4 Far.(23 inch	%Each	2	10440.5	20,881
32	PH/4	Providing and fixing European type white glazed earthen ware wash down W.C. pan complete with & including the cost of white / black plastic seat (Best quality) and lid with C.P. brass hinges best quality and buffers 3 gallons white glazed earthen ware low level flushing cistem with siphon fitting 1½ " dia white porcelain enameled flush bend dia and making requisite number of holes in walls , plinth & floor for pipe connection & making good in cement concrete 1:2:4	%Each	2	24100	48,200

33	PH/5	Providing and fixing 24x18" lavatory basin in white glazed earthen ware complete with & including the cost of W.I. or C.I. cantilever bracket 6 inches built into wall, painted white in two coats after a primary coat of red lead paint, a pair of ½" dia chrome plated pillar taps, 1-1/2" rubber plug & chrome plated brass chain 1-1/4" dia malleable iron or C.P. brass traps malleable iron or brass unions and making requisite number of holes in walls, plinth & floor for pipe connection & making good in cement concrete 1:2:4	%Each	2	9495.14	18,990
34	PH/6	Supplying & Fixing wash basin mixture of superior quality with C.P head 1/2" dia with swan type pillar cock of Superior quality single c.p. head 1/2" dia. and Providing & fixing in position nylon connection complete with 1/2" dia brass stop cock with pair of brass nuts and lining joints to nylon connection .	%Each	2	3773.25	7,547
35	PH/7	Upvc rain water down pipe 4"	%Rft	75	399.12	29,934
36	MI/1	Installation of ON Grid Solar System 50 KW (Grade-I)	%Nos	1	4836428	4,836,428
37	MI/2	Providing & Fixing appropriate numbers of Air Conditioners of 4 Ton	%Nos	8	800000	6,400,000

38	MI/3	Providing "Expansion Joint" in concrete work of 9" wide corugated PVC waterstop (with bulb) i.c soldering cost of material and labour etc complete.	%Rft	68	1800	122,400
39	SJ/1	Rehabilitation of External Sewerage by Repair Or Dismantling R.C.C / pipe & providing and laying New Manhole or Gully Trap where required.	%Rft	532	1000	532,000
40	EK/a/1	Providing & laying 20mm dia PVC Conduit recessed / surface (For light & Fan point wiring)	%Rft	1400	40	56,000
41	EK/a/2	Providing & laying 25mm dia PVC Conduit recessed / surface (For power plug & circuit wiring)	%Rft	2800	50	140,000
42	GCK/b/1	Providing & fixing 12mm dia GI Conduit (For light & Fan extension rod)	%Rft	350	360	126,000
43	WK/c/1	Providing & laying 1.5sq mm PVC wire single core stranded copper conductor in given PVC Conduit recessed / surface (For light & Fan point wiring)	%Rft	17500	31	542,500
44	WK/c/2	Providing & laying 2.5sq mm PVC wire single core stranded copper conductor in given PVC Conduit recessed / surface (For power plug, circuit and highbay light wiring)	%Rft	5000	64	320,000
45	WK/c/3	Providing & laying 4sq mm PVC wire single core stranded copper conductor in given PVC Conduit recessed / surface (For industrial socket wiring)	%Rft	2200	84	184,800

46	WK/c/4	Providing & laying 6sq mm PVC wire single core stranded copper conductor in given PVC Conduit recessed / surface (For SPlit AC wiring)	%Rft	150	121	18,150
47	WK/c/5	Providing & laying 25sq mm PVC wire single core stranded copper conductor in given PVC Conduit recessed / surface (For DB wiring)	%Rft	700	465	325,500
48	FFK/d/1	Providing & fixing PVC box recessed / surface size 3"x3" (For gang switch and socket)	%Nos	60	250	15,000
49	FFK/d/2	Providing & fixing PVC box recessed / surface size 6"x3" (For gang switch and socket)	%Nos	12	360	4,320
50	FFK/d/3	Providing & fixing PVC box recessed / surface size 8"x6" (For gang switch and socket)	%Nos	15	550	8,250
51	FFK/d/4	Providing & fixing 4 gang switch on given junction box good quality	%Nos	8	1250	10,000
52	FFK/d/5	Providing & fixing 6 gang switch on given junction box good quality	%Nos	12	1500	18,000
53	FFK/d/6	Providing & fixing 10A three pin switch and socket on given junction box good quality	%Nos	22	1400	30,800
54	FFK/d/7	Providing & fixing 15A three pin switch and socket on given junction box good quality	%Nos	16	1850	29,600
55	FFK/d/8	Providing & fixing 20A industrial socket on given junction box good quality	%Nos	15	2600	39,000
56	FFK/d/9	Providing & fixing fan clamp box good quality	%Nos	64	700	44,800

57	FFK/d/10	Providing & fixing ceiling fan 56" sweep good quality	%Nos	64	8500	544,000
58	FFK/d/11	Providing & fixing Industrial Exhaust Fan 36" dia	%Nos	1	90000	90,000
59	FFK/d/12	Providing & fixing fan dimmer good quality	%Nos	64	250	16,000
60	FFK/d/13	Providing and fixing 18" sweep metallic body exhaust fan complete with blades, motor, shutter etc including making hole in the wall & connection with 14.0076 flexible wire complete as required.	%Nos	9	9000	81,000
61	FFK/d/14	Providing & fixing PVC batten holder good quality	%Nos	107	180	19,260
62	FFK/d/15	Providing & fixing PVC ceiling rose good quality	%Nos	9	120	1,080
63	FFK/d/16	Providing & fixing LED bulb 30w good quality	%Nos	107	600	64,200
64	FFK/d/17	Providing & fixing LED down light 9w good quality	%Nos	40	750	30,000
65	FFK/d/18	Providing & fixing LED High bay light 60-100w good quality	%Nos	18	12500	225,000
66	CWK/e/1	providing and Installation of CCTV System with Complete Acessories	%Rft	11500	200	2,300,000
67	DBK/f/1	Providing & Fixing, testing,commissioning cubical type metal sheet distribution board flush / surface type with locking arrangement duly powder quoted paint including all fastening material including wiring with suitable gauge PVC wire complete in all respect.	%Sft	6	4300	25,800

68	CBK/g/1	Providing & fixing 10A to 32A SP MCB circuit breaker in given DB Terasaki or Equalent	%Nos	90	1500	135,000
69	CBK/g/2	Providing & fixing 20A to 32A DP MCCB circuit breaker in given DB Terasaki or Equalent	%Nos	8	2200	17,600
70	CBK/g/3	Providing & fixing 100A TP MCCB circuit breaker in given DB Terasaki or Equalent	%Nos	4	11500	46,000
71	CBK/g/4	Providing & fixing 200A TP MCCB circuit breaker in given DB Terasaki or Equalent	%Nos	1	18000	18,000
72	CBK/g/5	Providing & fixing pilot lamp in given DB good quality	%Nos	9	600	5,400
73	CBK/g/6	Providing & fixing Ampere meter in given DB good quality	%Nos	2	3500	7,000
74	CBK/g/7	Providing & fixing Volt meter in given DB good quality	%Nos	2	3500	7,000
75	ESK/h/1	Providing and fixing Earthing set with 2'x2'x1/8" copper plate buried in the ground at a depth of 12 feet or less if water comes out from the ground level (salt & charcoal, or earthing chemical powder) etc. making the pit 12 feet deep by excavation of all type of soil (except soft or hard rock) including fixing of 2x8 SWG copper wire in 1/2" dia GI conduit complete in all respect as required.	%Job	2	70000	140,000

76	ESK/h/2	Providing & fixing earth connecting strip size 150mmx20mmx6mm as required.	%Each	4	1500	6,000
77	CWK/i/1	P/Laying (Main or Sub Main) Pvc insulated / Pvc sheathed with size 4 core 95sq mm ug cable copper conductor (From Supply Point to M.DB)	%Rft	100	5200	520,000
78	FL/1	Examination Hall Seats Good Quality	%Nos	220	6000	1,320,000
79	RWA/1	Dismantling Block masonry including disposing of surplus material and Providing & laying pre-cast solid blocks masonry using 6"x8"x12" size pre-cast blocks of min 1000 psi compressive strength set in cement mortar 1:5 in any floor superstructure including scaffolding, raking out joints & curing and plastering with 1/2" (13 mm) thick cement plaster 1:6 complete. complete and as per instructions of engineer in charge	%Cft	1460	872.93	1,274,478
80	RWA/2	Clearing and grubbing the site by cutting, uprooting and removing all rubbish and shrubs including disposal to (outside limits) designated places.	%Sft	9430	1.8	16,974

81	RWA/3	Providing loose concrete near the Corroded Exposed Rebars and adjacent to the corroded area, wire brushing of rebars, applying zinc Rich on Rebars, nailing the treated surface by concrete nails if 8 BWG, applying SBR all around the surface, placing 20 BWG Expanded Metal and laying with installed nails and plastering with 1:3 cement sand Mortar mixed with plasticizer and finishing the surface to fine and level the surrounding surface.	%Sft	953	2911.66	2,774,812
82	RWA/4	Rehabilitation of Columns By cutting the damaged surface and brushing of existing steel bars to remove the rust, and coating the bars with zinc rich primer to protect from rust, add new bars where required by drilling holes and filling the holes with chemical grout and concreting the column with 5000PSI Concrete as per drawings, site requirement and direction of engineer incharge.	%Sft	70	953.67	66,757
83	CPB/1	3/4" (19 mm) thick cement plaster 1:4 including making edges, corners, and curing etc. (External Plaster)	%Sft	1200	73	87,600
84	PC/1	Removal of old Paint and Painting three coats with weather shield paint (Each coat will be applied after 5 Days)	%Sft	20	52.24	1,045

85	PC/2	Removal of old Paint and Distempering three coats with poly vinyl distemper (Each coat will be applied after 5 Days)	%Sft	98	43.02	4,216
86	PC/3	Removal of old Paint and Preparing the surface and painting three coats with matt finish (Each coat will be applied after 5 Days)	%Sft	248	56.76	14,076
87	FD/1	Providing & laying floor of mosaic marble chips tile 1" (25mm) thick of approved quality and shade laid in white cement and pigment over 3/4" (20mm) thick bedding in cement sand mortar 1:2 including finishing and polishing complete as per Approval of Client	%Sft	4451	222.88	992,039
88	FD/2	Laying Verona marble flooring Size 24"x12"x1"/12"x12"x1" fine dressed on the surface without winding set in lime mortar 1:2 including rubbing and polishing of the joints b) 1" thick marble	%Sft	2806	381.88	1,071,555
89	FD/3	Laying floor of approved with glazed tiles 1/4" thick dado of approved color & size jointing in white cement and laid over 1:2 cement sand mortar 3/4" thick including grouting with matching color and finishing	%Sft	1302	389.36	506,947

90	FD/4	P/F Granite Strips (5"x1"x1") thick fixed over stair steps of required width set in cement sand mortar 1:2 in gray cement 1"thick in/c washing and filling etc complete.	%Sft	612	1500	918,000
91	FD/5	Providing & Laying Full Body Porcelain Tile in Flooring or Facing of Approved Design Set in Gry Cement Motor 1:2 or of 3/4" Thickinss I/C Washing & Joints With White Cement Slurry Using Colour Pigment for matching complete as per Spacification 16"x16"x5/16" thick flooring	%Sft	6697	389.36	2,607,544
92	FD/6	Providing and laying, CC Paving stone, 50 mm thick in natural colour, as in floors, ramps etc, any Reference and any shape, are fixed using 1:4 motar 3/4" thick and slurry of cement as the practice adopted in tiles ,granite or marble as per drawing and instruction engineer in charge.	%Sft	2670	230	614,100
93	FD/7	Stone cladding of required size on wall facing of approved design shape and pattern set in cement sand mortar ratio 1:2 in gray cement 3/4" thick in/c washing of joints with net white cement salary and pigment in desire shape in/c cutting and dressing the stone tile to proper profile in/c labour etc complete as per specification as directed by the Engineer / Incharge.	%Sft	1920	541.93	1,040,506

94	RTE/1	Providing water proofing roof treatment by Dismantling old Screeding and providing hot bitumen layer with Insulation Board and sand as slope after screeding provided for water drainage.	%Sft	45711	104.96	4,797,827
95	RTE/2	Providing and laying 3" thick topping of cement concrete (1:2:4) including Surface finishing and dividing into panels:	%Sft	45711	145	6,628,095
96	DWF/1	Providing and fixing fully glazed aluminium Sliding windows & Ventilator box section including the cost of glass pan, aluminium fittings, with all accessories cutting hole etc. and making good damages to walls etc. complete as required in any floor as per direction of engineer-in-charge	%Sft	20	1358.5	27,170
97	DWF/2	First Class deodar wood wrought joinery in doors and windows etc. panelled or panelled or glazed or fully glazed fixed in position including chowkhat, holdfast, hinges, tower bolt rubber stop cleats/G I clamp, handles and chord with hooks etc. complete (excluding sliding bolts or lock).	%Sft	124	3000	372,000
98	DWF/3	Supplying & fixing in position iron/steel grill of 3/4" x 1/4" size flat iron of approved design including painting 3 coats etc. complete (weight not to be less than 3.7 Lbs./Sq . Foot of finished grill)	%Sft	24	1125	27,000

99	PPG/1	Excavation for Plinth Protection about 1.5ft wide & 1.5ft Deep and Providing CC 1:4:8 Below Foundation with 6" Thick Block Masonry and laying 50mm Pavers, 2" Thick Sand Cushion, 4" Thk Gravel Layer and 4" Thk 1:3:6 as Per Direction of Engineer-in-Charge.	%Rft	1958	5617.82	10,999,692
100	PH/1/a	25mm 1" --PPRC pipe PN-20	%Rft	110	899.4	98,934
101	PH/1/b	50mm 2" --PPRC pipe PN-20	%Rft	70	3753.42	262,739
102	PH/1/c	1 inches (25mm) dia Ball Valve	%Each	9	212.256	1,910
103	PH/1/d	1-1/2 inches (40mm) dia Ball Valve	%Each	8	399.26	3,194
104	PH/1/e	2 inches (50mm) dia Ball Valve	%Each	5	652.26	3,261
105	PH/1/g	4 inches (100 mm) dia pipe. --(U.P.V.C) "E" class	%Rft	60	5354.32	321,259
106	PH/2	Supplying & fixing Fiber glass tank of approved quality and design and wall thickness as specified including cost of nuts, bolts and fixing in plat form of cement concrete 1:3:6 and making connection for inlet, outlet and over flow pipes etc. complete 350 gallons tank with wall thickness 4.0mm	%Each	3	50000	150,000

107	PH/3	Providing and fixing squatting type white glazed earthen ware W.C pan with front flush inlet & complete with including the cost of flushing cistern with internal fitting and flush pipe with bend and requisite number of holes in walls plinth & floor for pipe connection & making good in cement concrete 1:2:4 Far.(23 inch	%Each	9	10440.5	93,965
108	PH/4	Providing and fixing 24x18" lavatory basin in white glazed earthen ware complete with & including the cost of W.I. or C.I. cantilever bracket 6 inches built into wall, painted white in two coats after a primary coat of red lead paint, a pair of ½" dia chrome plated pillar taps, 1-1/2" rubber plug & chrome plated brass chain 1-1/4" dia malleable iron or C.P. brass traps malleable iron or brass unions and making requisite number of holes in walls, plinth & floor for pipe connection & making good in cement concrete 1:2:4	%Each	9	9495.14	85,456
109	PH/5	Supplying & Fixing wash basin mixture of superior quality with C.P head 1/2" dia with swan type pillar cock of Superior quality single c.p. head 1/2" dia. and Providing & fixing in position nylon connection complete with 1/2" dia brass stop cock with pair of brass nuts and lining joints to nylon connection .	%Each	9	3773.25	33,959

110	PH/6	Providing and fixing flat black lipped front urinal basin (of not less than 17 " in height) of white glazed earthen ware complete with & including the cost of ½ " dia gun metal gate valve with standard flush pipe , waste pipe (enameled iron) complete with fitting and making requisite number of holes in walls , plinth & floor for pipe connection & making good in cement concrete 1:2:4 . (Standard pattern)	%Each	5	4464.14	22,321
111	PH/7	Upvc rain water down pipe 4"	%Rft	320	399.12	127,718
112	MI/1	2" Thick Asphalt Concrete Wearing Course Mix Laying mechanically to proper Asphalt Concrete incharge rolling and finishing to design Proper grade line level and comber etc	%Sft	161900	70	11,333,000
113	MI/2	Providing & Fixing appropriate numbers of Air Conditioners of 4 Ton	%Nos	2	800000	1,600,000
114	MI/3	Making and fixing fiber glass sun shade standard size 3mm sheet (02 layer) molded in panel in/c M.S Pipe 6" dia 20' height at 20' center fixing C.C foundation with M.S Square pipe 1-1/2" x 1-1/2" double kanchi around from with internal M.S Square pipe 2x2 center to center in/c welding assembling etc complete in all respect	%Each	2400	1200	2,880,000
115	MI/4	Deodar wood counter including shutters and shelves complete with iron fitting.	%Sft	692	5000	3,460,000

116	MI/5	Providing "Expansiomn Joint" in concrete work of 9" wide corugated PVC waterstop (with bulb) i.c soldering cost of material and labour etc complete.	%Rft	805	1000	805,000
117	SJ/1	Rehabilitation of External Sewerage by Repair Or Dismantling R.C.C / pipe & providing and laying New Manhole or Gully Trap where required.	%Rft	1794	1000	1,794,000
118	SJ/2	Supplying and fixing Centrifugal Pumping set complete with AC, electric motor driven, 400 volts, 3 phase, 50 cycles, 1 hp, mounted on a common channel base, total head 25/30 M	%Each	1	112033	112,033
119	EK/a/1	Providing & laying 20mm dia PVC Conduit recessed / surface (For light & Fan point wiring)	%Rft	40	40	1,600
120	EK/a/2	Providing & laying 25mm dia PVC Conduit recessed / surface (For power plug & circuit wiring)	%Rft	15	50	750
121	EK/c/3	Providing & laying 1.5sq mm PVC wire single core stranded copper conductor in given PVC Conduit recessed / surface (For light & Fan point wiring)	%Rft	100	31	3,100
122	EK/c/4	Providing & laying 2.5sq mm PVC wire single core stranded copper conductor in given PVC Conduit recessed / surface (For power plug, circuit and highbay light wiring)	%Rft	40	64	2,560
123	EK/d/1	Providing & fixing PVC box recessed / surface size 3"x3" (For gang switch and socket)	%Nos	2	250	500

124	EK/d/2	Providing & fixing 4 gang switch on given junction box good quality	%Nos	1	1250	1,250
125	EK/d/3	Providing & fixing 10A three pin switch and socket on given junction box good quality	%Nos	1	1400	1,400
126	EK/d/4	Providing & fixing fan clamp box good quality	%Nos	1	700	700
127	EK/d/5	Providing & fixing ceiling fan 56" sweep good quality	%Nos	1	8500	8,500
128	EK/d/6	Providing & fixing fan dimmer good quality	%Nos	1	250	250
129	EK/d/7	Providing & fixing PVC batten holder good quality	%Nos	4	180	720
130	EK/d/8	Providing & fixing LED bulb 30w good quality	%Nos	29	600	17,400
131	EK/e/1	Providing & Fixing, testing, commissioning cubical type metal sheet distribution board flush / surface type with locking arrangement duly powder quoted paint including all fastening material including wiring with suitable gauge PVC wire complete in all respect.	%Sft	4	4300	17,200
132	EK/g/1	Providing & fixing 10A to 32A SP MCB circuit breaker in given DB Terasaki or Equalent	%Nos	38	1500	57,000
133	EK/g/2	Providing & fixing 20A to 32A DP MCCB circuit breaker in given DB Terasaki or Equalent	%Nos	2	2200	4,400
134	EK/g/3	Providing & fixing 100A TP MCCB circuit breaker in given DB Terasaki or Equalent	%Nos	1	11500	11,500

135	EK/g/4	Providing & fixing 200A TP MCCB circuit breaker in given DB Terasaki or Equalent	%Nos	1	18000	18,000
136	EK/g/5	Providing & fixing pilot lamp in given DB good quality	%Nos	3	600	1,800
137	EK/g/6	Providing & fixing Ampere meter in given DB good quality	%Nos	1	3500	3,500
138	EK/g/7	Providing & fixing Volt meter in given DB good quality	%Nos	1	3500	3,500
139	FABL/1	Chart Table	%Nos	80	8250	660,000
140	FABL/2	Table	%Nos	2	13200	26,400
141	FMCM/1	Clinical Couch	%Nos	6	30800	184,800
142	FMCM/2	Examination Trolley	%Nos	6	24750	148,500
143	FMCM/3	Bed	%Nos	15	33000	495,000
144	FMCM/4	Sofa Set	%Nos	25	23100	577,500
145	FMCM/5	Chairs	%Nos	25	20350	508,750
146	FMCM/6	Staff Table	%Nos	5	50160	250,800
147	FMCM/7	Office Table	%Nos	4	61380	245,520
148	FMCM/8	Bed, Patient, Electric	%Nos	2	302500	605,000
149	FMCM/9	Cabinet (Fixed/ Display Cabinet)	%Nos	4	75625	302,500
150	FMCM/10	Wheel Chair	%Nos	4	22000	88,000

151	FMCM/11	Workstation	%Nos	2	38500	77,000
152	FMCM/12	Waiting Chairs	%Nos	14	13200	184,800
153	FMCM/13	Ward Screen	%Nos	15	12122	181,830
					GRAND TOTAL:	Rs116,319,870.00

Scope of Work

SCOPE OF WORKS

Repair \ renovation and refurbishment of admin block, medical center, parade ground, sports complex, swimming pool & examination hall at Pakistan marine academy

TECHNICAL SPECIFICATIONS

Table of Contents

CIVIL WORKS

1. Section-1 General
2. Section-2 Site Clearing, Grubbing and Setting out of Works
3. Section-3 Excavation, Filling, Backfill and Disposal

4. Section-4 Termite Control
5. Section-5 Water
6. Section-6 Concrete
7. Section-7 Steel Reinforcement

ARCHITECTURAL AND FINISHES WORKS

8. Section-8 Block Masonry
9. Section-9 Plastering
10. Section-10 Flooring
11. Section-11 Wooden Doors and Windows
12. Section-12 Timber Joinery and Hardware
13. Section-13 Aluminum Anodized Doors/Windows and Ventilators
14. Section-14 False Ceiling
15. Section-15 Glass & Glazing
16. Section-16 Roof Treatment
17. Section-17 Painting / Distemping
18. Section-18 Color Creting

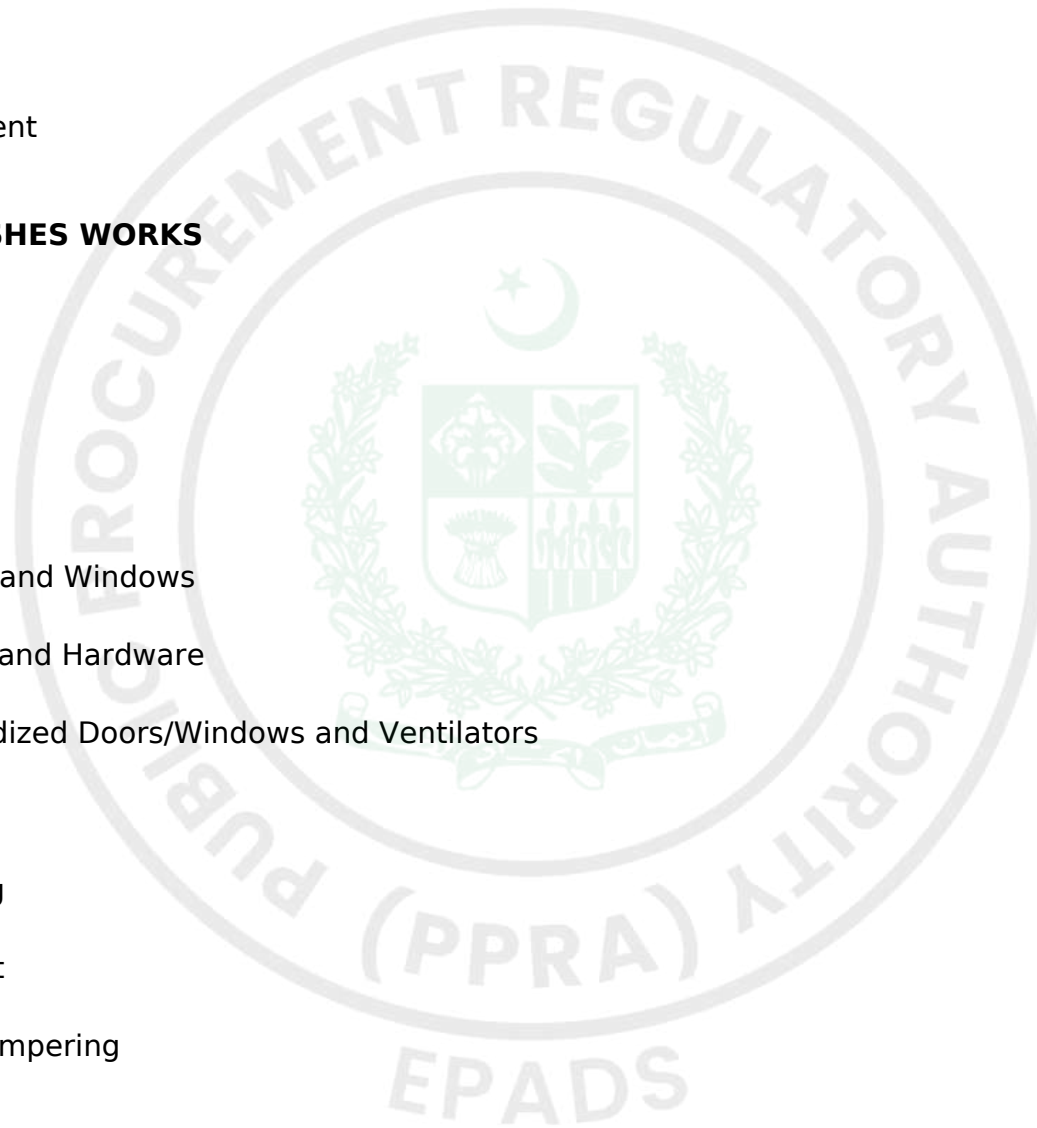

19. Section-19 Steel Windows, Ventilators, Gates and Grills

20. Section-20 Structural Steel Works

ELECTRICAL WORKS

PLUMBING WORKS

Price Schedule

For Individual Jobs

#	Job Title	Quantity	Unit Price (PKR)	Total Price (PKR)	Delivery Location	Delivery Period / Year	Country of Origin
1							
2							

For Lots

#	Lot Title	Total Lot Price (PKR)	Country of Origin
1	[Lot 1 Title]		





General Conditions of Contract

A. General

1. Definitions

1.1. Unless the context otherwise requires, the following terms whenever used in this Contract shall have the same meaning and shall be interpreted as indicated

1.1.1. "Applicable Law" means the laws and any other instruments having the force of law in the Government's Country, or in such other country as may be specified in the Special Conditions of the Contract (SC), as they may be issued and in force from time to time;

1.1.2. "The Contract" means an agreement enforceable by law;

1.1.3. "The Contract Price" means the price payable to the Contractor under the Contract for the full and proper performance of its contractual obligations;

1.1.4. "The Services" means the work to be performed by the Contractor pursuant to this Contract and as prescribed in the Specifications and Schedule of Activities included in the Contractor's Bid;

1.1.5. "Ancillary Services" means those services ancillary to the provision of Services, such as transportation and insurance, and any other incidental services, such as installation, commissioning, provision of technical assistance, training, and other such obligations of the Contractor covered under the Contract;

1.1.6. "GCC" means the General Conditions of Contract contained in this section;

1.1.7. "SCC" means the Special Conditions of Contract by which the GCC may be amended or supplemented;

1.1.8. "Day" means calendar day unless indicated otherwise;

1.1.9. "Effective Date" means the date on which this Contract comes into force and effect;

1.1.10. "The Contractor" means the individual or corporate body whose Bids to provide the Services has been accepted by the Procuring Agency;

1.1.11. "The Project Site," where applicable, means the place or places named in Bid Data Sheet and technical Specifications;

1.1.12. "Government" means the Government of Pakistan;

1.1.13. "Local Currency" means the currency of Pakistan;

1.1.14. "In Writing" means communicated in written form with proof of receipt;

1.1.15. "Completion Date" means the date of completion of the Services by the Contractor as certified by the Procuring Agency;

1.1.16. "Foreign Currency" means any currency other than the currency of the country of the Procuring Agency;

1.1.17. "Party" means the Procuring Agency or the Contractor, as the case may be, and "Parties" means both of them;

1.1.18. "Service" means any object of procurement other than goods or works;

1.1.19. "Subcontractor" means any entity to which the Bidder subcontracts any part of the Services.

2. Applicable Law

2.1. The contract shall be governed and interpreted in accordance with the laws of Pakistan, unless otherwise specified in SCC.

3. Language

3.1. The Contract as well as all correspondence and documents relating to the Contract exchanged between the Contractor and the Procuring Agency, shall be written in the **English language** unless otherwise stated in the SCC. Supporting documents and printed literature that are part of the Contract may be in another language provided these are accompanied by an accurate translation of the relevant passages in English, in which case, for purposes of interpretation of the Contract, this translation shall govern.

4. Notices

4.1. Any notice, request, or consent made pursuant to this Contract shall be in writing and shall be deemed to have been made when delivered in person to an authorized representative of the Party to whom the communication is addressed, or when sent by registered mail, telex, telegram, or facsimile to such Party at the address specified in the SCC.

5. Location

5.1. The Services shall be performed at such locations as the Procuring Agency may approve and as specified in SCC.

5.2. A {DOCUMENTS}

6. Authorized Representatives / Authority of Member in charge

6.1. Any action required or permitted to be taken, and any document required or permitted to be executed, under this Contract by the Procuring Agency or the Contractor may be taken or executed by the officials specified in the SCC.

B. Commencement, Completion, Modification, and Termination of Contract

1. Effectiveness of Contract

1.1. This Contract shall come into effect on the date the Contract is signed by both parties and such other later date as may be stated in the SCC.

2. Commencement of Services

2.1. The Contractor shall confirm availability of Key Experts and begin carrying out the Services not later than the number of days after the Effective Date specified in the SCC.

3. Program schedule

3.1. Before commencement of the Services, the Contractor shall submit to the Procuring Agency for approval a Program showing the general methods, arrangements, order and timing for all activities. The Services shall be carried out in accordance with the approved Program as updated.

4. Starting Date/Expiration Date

4.1. The Contractor shall start carrying out the Services Five (05) days after the date the Contract becomes effective, or at such other date as may be specified in the SCC.

4.2. Unless terminated earlier pursuant to Clause **GCC 14** hereof, this Contract shall expire at the end of such time period after the Effective Date as specified in the SCC.

5. Entire Agreement

5.1. This Contract contains all covenants, stipulations and provisions agreed by the Parties. No agent or representative of either Party has authority to make, and the Parties shall not be bound by or be liable for, any statement, representation, promise or agreement not set forth herein.

6. Modification

6.1. Any modification or variation of the terms and conditions of this Contract, including any modification or variation of the scope of the Services, may only be made by written agreement between the Parties. However, each Party shall give due consideration to any modification(s) or variation(s) made by the other Party.

6.2. In cases of any modification(s) or variation(s), the prior written consent of the Procuring Agency is required.

7. Force Majeure

7.1. Definition

For the purposes of this Contract, "Force Majeure" means an event which is beyond the reasonable control of a Contractor and which makes a Contractor's performance of its obligations under the Contract impossible or so impractical as to be considered impossible under the circumstances.

7.2. No Breach of Contract

The failure of a Party to fulfill any of its obligations under the contract shall not be considered to be a breach of, or default under, this Contract in so far as such inability arises from an event of Force Majeure, provided that the Party affected by such an event (a) has taken all reasonable precautions, due care and reasonable alternative

measures in order to carry out the terms and conditions of this Contract, and (b) has informed the other Party as soon as possible about the occurrence of such an event.

7.3. Extension of Time

Any period within which a Contractor shall, pursuant to this Contract, complete any action or task, shall be extended for a period equal to the time during which such Party was unable to perform such action as a result of Force Majeure.

7.4. Payments

During the period of their inability to perform the Services as a result of an event of Force Majeure, the Contractor shall be entitled to continue to be paid under the terms of this Contract, as well as to be reimbursed for additional costs reasonably and necessarily incurred by them during such period for the purposes of the Services and in reactivating the Service after the end of such period.

8. Termination

8.1. By the Procuring Agency

The Procuring Agency may terminate this Contract in case of the occurrence of any of the events specified in paragraphs (a) through (e) of this Clause. In such an occurrence the Procuring Agency shall give at least thirty (30) calendar days' written notice of termination to the Contractor in case of the events referred to in (a) through (d); at least sixty (60) calendar days' written notice in case of the event referred to in (e);

8.1.1. If the Contractor fails to remedy a failure in the performance of its obligations hereunder, as specified in a notice of suspension;

8.1.2. If the Contractor becomes (or, if the Contractor consists of more than one entity, if any of its members becomes) insolvent or bankrupt or enter into any agreements with their creditors for relief of debt or take advantage of any law for the benefit of debtors or go into liquidation or receivership whether compulsory or voluntary;

8.1.3. If the Contractor fails to comply with any final decision reached as a result of arbitration proceedings;

8.1.4. If, as the result of Force Majeure, the Contractor is unable to perform a material portion of the Services for a period of not less than sixty (60) calendar days;

8.1.5. If the Procuring Agency, in its sole discretion and for any reason whatsoever, decides to terminate this Contract;

8.2. By the Contractor

The Contractor may terminate this Contract, by not less than thirty (30) calendar days' written notice to the Procuring Agency, in case of the occurrence of any of the events specified in paragraphs (a) through (d) of this Clause.

8.2.1. If the Procuring Agency fails to pay any money due to the Contractor pursuant to this Contract and not subject to dispute within forty-five (45) calendar days after receiving written notice from the Contractor that such payment is overdue;

8.2.2. If, as the result of Force Majeure, the Contractor is unable to perform a material portion of the Services for a period of not less than sixty (60) calendar days;

8.2.3. If the Procuring Agency fails to comply with any final decision reached as a result of arbitration;

8.2.4. If the Procuring Agency is in material breach of its obligations pursuant to this Contract and has not remedied the same within forty-five (45) days (or such longer period as the Bidder may have subsequently approved in writing) following the receipt by the Procuring Agency of the Contractor's notice specifying such breach.

C. Obligations of the Contractor

1. General

1.1. Standard of Performance

1.1.1. The Contractor shall perform the Services and carry out the Services with all due diligence, efficiency and economy, in accordance with generally accepted professional standards and practices, and shall observe sound management practices, and employ appropriate technology and safe and effective equipment, machinery, materials and methods. The Contractor shall always act, in respect of any matter relating to this Contract or to the Services, as a faithful adviser to the Procuring Agency, and shall at all times support and safeguard the Procuring Agency's legitimate interests in any dealings with the third parties;

1.1.2. The Contractor shall employ and provide such qualified and experienced Experts and Sub-Contractors as are required to carry out the Services.

1.2. Law Applicable to Services

The Contractor shall perform the Services in accordance with the Contract and in accordance with the Law of Pakistan and shall take all practicable steps to ensure that any of its Experts and Sub-Bidders, comply with the Applicable Law.

2. Conflict of Interests

2.1. Contractor Not to Benefit from Commissions and Discounts

The remuneration of the Contractor shall constitute the Contractor's sole remuneration in connection with this Contract or the Services, and the Contractor shall not accept for their own benefit any trade commission, discount, or similar payment in connection with activities pursuant to this Contract or to the Services or in the discharge of their obligations under the Contract, and the Contractor shall use their best efforts to ensure that the Personnel, any Subcontractors, and agents of either of them similarly shall not receive any such additional remuneration.

2.2. Contractor and Affiliates Not to be Otherwise Interested in Project

The Contractor agree that, during the term of this Contract and after its termination, the Contractor and its affiliates, as well as any Subcontractor and any of its affiliates, shall be disqualified from providing Services (other than the Services and any continuation thereof) for any project resulting from or closely related to the Services.

2.3. Prohibition of Conflicting Activities

Neither the Bidder nor its Subcontractors nor the Personnel shall engage, either directly or indirectly, in any of the following activities:

- 2.3.1. during the term of this Contract, any business or professional activities in the Government's country which would conflict with the activities assigned to them under this Contract;
- 2.3.2. during the term of this Contract, neither the Contractor nor their Subcontractors shall hire public employees in active duty or on any type of leave, to perform any activity under this Contract;
- 2.3.3. after the termination of this Contract, such other activities as may be specified in the **SCC**.

3. Insurance to be Taken Out by the Contractor

3.1. The Contractor(a) shall take out and maintain, and shall cause any Subcontractors to take out and maintain, at its (or the Sub-contractors', as the case may be) own cost but on terms and conditions approved by the Procuring Agency, insurance against the risks, and for the coverage, as shall be specified in the **SCC**; and (b) at the Procuring Agency's request, shall provide evidence to the Procuring Agency showing that such insurance has been taken out and maintained and that the current premiums have been paid.

4. Contractor's Actions Requiring Procuring Agency's Prior Approval

4.1. The Contractor shall obtain the Procuring Agency's prior approval in writing before taking any of the following actions:

- 4.1.1. appointing such members of the Personnel not provided by the Contractor;
- 4.1.2. changing the Program of activities; and
- 4.1.3. any other action that may be specified in the **SCC**.

5. Reporting Obligations

5.1. The Contractor shall submit to the Procuring Agency the reports and documents in the numbers, and within the periods as prescribed by the Procuring Agency.

6. Liquidated Damages

6.1. Payments of Liquidated Damages

The Contractor shall pay liquidated damages to the Procuring Agency at the rate per day stated in the **SCC** for each day that the Completion Date is later than the Intended Completion Date. The total amount of liquidated damages shall not exceed the amount defined in the **SCC**. The Procuring Agency may deduct liquidated damages from payments due to the Contractor. Payment of liquidated damages shall not affect the Contractor's liabilities.

6.2. Correction for Over-payment

If the Intended Completion Date is extended after liquidated damages have been paid, the Procuring Agency shall correct any overpayment of liquidated damages by the Contractor by adjusting the next payment certificate. The

Contractor shall be paid interest on the overpayment, calculated from the date of payment to the date of repayment, at the rates specified in **SCC**.

6.3. Lack of performance penalty

If the Contractor has not corrected a Defect within the time specified in the Procuring Agency's notice, a penalty for Lack of performance will be paid by the Contractor. The amount to be paid will be calculated as a percentage of the cost of having the Defect corrected, assessed as specified in the Contractor

7. Performance Guarantee

7.1. Within the time stipulated in the acceptance letter from the Procuring Agency, the successful Bidder shall furnish the Performance Guarantee in shape and amount **specified in SCC**.

7.2. The proceeds of the Performance Guarantee shall be payable to the Procuring agency as compensation for any loss resulting from the Supplier's failure to complete its obligations under the Contract.

7.3. The Performance Guarantee shall be denominated in the currency of the Contract, or in a freely convertible currency acceptable to the Procuring agency and shall be in the acceptable form as specified in **SCC**.

7.4. The Performance Guarantee will be discharged by the Procuring agency and returned to the Supplier not later than thirty (30) days following the date of completion of the Supplier's performance obligations under the Contract, including any warranty obligations, unless otherwise **specified in SCC**.

8. Sustainable Procurement

8.1. The Contractor shall conform to the sustainable procurement contractual provisions, if and as specified in the **SCC**.

D. Contractor's Personnel

1. Description of Personnel

1.1. The titles, agreed job descriptions, minimum qualifications, and estimated periods of engagement in the carrying out of the Services of the Contractor's Key Personnel. The Key Personnel listed by title as well as by name are hereby approved by the Procuring Agency.

2. Removal and / or Replacement of Personnel

2.1. Except as the Procuring Agency may otherwise agree, no changes shall be made in the Key Personnel. If, for any reason beyond the reasonable control of the Contractor, it becomes necessary to replace any of the Key Personnel, the Contractor shall provide as a replacement a person of equivalent or better qualifications.

2.2. If the Procuring Agency finds that any of the Personnel have (i) committed serious misconduct or have been charged with having committed a criminal action, or (ii) have reasonable cause to be dissatisfied with the performance of any of the Personnel, then the Contractor shall, at the Procuring Agency's written request specifying the grounds thereof, provide as a replacement a person with qualifications and experience acceptable to the Procuring Agency.

2.3. The Contractor shall have no claim for additional costs arising out of or incidental to any removal and/or replacement of Personnel.

E. Obligations of the Procuring Agency

1. Change in the Applicable Law

1.1. If, after the date of this Contract, there is any change in the Applicable Law with respect to taxes and duties which increases or decreases the cost of the Services rendered by the Contractor, then the remuneration and reimbursable expenses otherwise payable to the Contractor under this Contract shall be increased or decreased accordingly by agreement between the Parties, and corresponding adjustments shall be made to the amounts referred in the **SCC**.

2. Services and Facilities

2.1. The Procuring Agency shall make available to the Contractor and the Experts, for the purposes of the Services and free of any charge, the services, facilities and property described in the Terms of Reference, at the times and in the manner specified in the Terms of Reference.

2.2. In case that such services, facilities and property shall not be made available to the Contractor, the Parties shall agree on (i) any time extension that it may be appropriate to grant to the Contractor for the performance of the Services, (ii) the manner in which the Contractor shall procure any such services, facilities and property from other sources, and (iii) the additional payments, if any, to be made to the Contractor as a result thereof.

F. Payments to the Contractor

1. Contract Price

1.1. The price payable shall be in Pakistani Rupees unless otherwise specified in the **SCC**.

2. Terms and Conditions of Payment

2.1. Payments will be made to the Contractor according to the payment schedule stated in the **SCC** and as per actual invoice submitted by the Contractor.

2.2. Unless otherwise stated in the **SCC**, the advance payment shall be made against the provision by the Contractor of a bank guarantee for the same amount, and shall be valid for the period stated in the **SCC**. Any other payment shall be made after the conditions listed in the **SCC** for such payment have been met, and the Contractor have submitted an invoice to the Procuring Agency specifying the amount due.

3. Quality Control Identifying Defects

3.1. The principle and modalities of Inspection of the Services by the Procuring Agency shall be as indicated in the **SCC**. The Procuring Agency shall check the Contractor's performance and notify him of any Defects that are

found. Such checking shall not affect the Contractor's responsibilities. The Procuring Agency may instruct the Contractor to search for a Defect and to uncover and test any service that the Procuring Agency considers may have a Defect. Defect Liability Period is as defined in the **SCC**.

3.2. A {INSPECTION}

4. Correction of Defects, and Lack of Performance Penalty

4.1. The Procuring Agency shall give notice to the contractor of any Defects before the end of the Contract. The Defects liability period shall be extended for as long as Defects remain to be corrected.

4.2. Every time notice a Defect is given; the contractor shall correct the notified Defect within the length of time specified by the Procuring Agency's notice.

4.3. If the contractor has not corrected a Defect within the time specified in the Procuring Agency's notice, the Procuring Agency will assess the cost of having the Defect corrected, the contractor will pay this amount, and a Penalty for Lack of Performance.

5. Settlement of Disputes Amicable Settlement

5.1. The Parties shall use their best efforts to settle amicably all disputes arising out of or in connection with this Contract or its interpretation.

6. Dispute Settlement

6.1. Arbitration

If any dispute of any kind whatsoever shall arise between the procuring agency and the contractor in connection with or arising out of the Contract, including without prejudice to the generality of the foregoing, any question regarding its existence, validity or termination, or the execution of the contract, the parties shall seek to resolve any such dispute or difference by mutual consultation. If the parties fail to resolve such a dispute or difference even after negotiations or mediation, then the dispute shall be referred within fourteen (14) days in writing by either party to the Arbitrator, with a copy to the other party.

Any dispute in respect of which a notice of intention to commence arbitration has been given, in accordance with **GCC sub-clause 32.1**, shall be finally settled by arbitration. Arbitration may be commenced prior to or after completion of the Contract. Arbitration proceedings shall be conducted in accordance with Arbitration Act 1940. Notwithstanding any reference to arbitration herein, the parties shall continue to perform their respective obligations under the Contract unless otherwise agreed. The Procuring Agency shall continue to pay the Contractor any undisputed amounts due under the Contract during the resolution of any dispute.



Special Conditions of Contract

SECTION VIII. SPECIAL CONDITIONS OF CONTRACT

The following Special Conditions of Contract shall supplement the General Conditions of Contract. Whenever there is a conflict, the provisions herein shall prevail over those in the Conditions of Contract. The corresponding clause number of the GCC is indicated in parentheses.

Number of GC Clause	Amendments of, and Supplements to, Clauses in the General Conditions of Contract
	<p>Definitions</p> <p>The Procuring Agency is:PNSC (CSR),Actg. General Manager FinanceFINANCE DEPARTMENT, 12TH FLOOR, PNSC BUILDING, M.T KHAN ROAD, KARACHI</p> <p>The Supplier is:</p> <p>The title of the subject procurement is:REPAIR RENOVATION AND REFURBISHMENT OF ADMIN BLOCK, MEDICAL CENTER, PARADE GROUND, SPORTS COMPLEX, SWIMMING POOL & EXAMINATION HALL AT PAKISTAN MARINE ACADEMY</p>
GCC 2	<p>Applicable/Governing Law:</p> <p>The Contract shall be interpreted in accordance with the laws of Islamic Republic of Pakistan</p>
GCC 3	<p>Language:</p> <p>The language of the Contract, all correspondence and communications to be given, and all other documentation to be prepared and supplied under the Contract shall be in English.</p>

<p>GCC 4</p>	<p>Notices:</p> <p>The addresses for the notices are:</p> <p>Procuring Agency:</p> <p>PNSC (CSR),Actg. General Manager Finance FINANCE DEPARTMENT, 12TH FLOOR, PNSC BUILDING, M.T KHAN ROAD, KARACHI +92-333-326-2196 shoais.pervaiz@pns.com.pk</p> <p>Contractor/ Bidder:</p> <p>[Name, address and telephone number].</p> <p>The Contractor/ Bidder’s Representative(s)</p> <p>[Name, address, telephone number and e-mail address]</p>
<p>GCC 6.1</p>	<p>The Authorized Representatives are:</p> <p>For the Procuring Agency:</p> <p>PNSC (CSR),Actg. General Manager Finance FINANCE DEPARTMENT, 12TH FLOOR, PNSC BUILDING, M.T KHAN ROAD, KARACHI +92-333-326-2196 shoais.pervaiz@pns.com.pk</p> <p>For the Bidder:</p> <p>Name:</p> <p>Designation:</p> <p>Address:</p>
<p>GCC 7</p>	<p>Effectiveness of the contract</p> <p>The Contractor/Bidder shall be effective within days from the date of signature of the Contract by both parties</p>
<p>GCC 8</p>	<p>Commencement of Contract:</p> <p>The Contractor/ Bidder shall provide Non-Consultancy Services from the effective date of contract.</p>

<p>GCC 10.2</p>	<p>Expiration of Contract:</p> <p>The time period shall be</p>
<p>GCC 14</p>	<p>Termination</p> <p>In the event of termination of the contract due to any reason as already defined in the General Conditions of Contract, the Bidder shall be responsible for providing to the Authority the Goods till the time of alternate arrangements.</p>
<p>GCC 16</p>	<p>Conflict of Interest:</p> <p>The Procuring Agency reserves the right to determine on a case-by-case basis whether the Bidder should be disqualified from providing goods or services due to a conflict of a nature described in Clause GCC 17.</p>
<p>GCC 20</p>	<p>Liquidated Damages</p> <p>If the Bidder fails to provide services as required under the contract or in case of any data loss/data breach or any incident compromising the data security or other such failures related to any services, the Bidder shall pay to the Procuring Agency as Liquidated Damages at a rate of 0.10% to 10.00% of the Contract value, in accordance with the extent of performance failure & the cost of investigating such incidents as judged by the Authority.</p>
<p>GCC 21</p>	<p>Performance Guarantee:</p> <p>The amount of performance guarantee shall be 5.00% of the contract price in acceptable form of Pay Order, Bank Guarantee</p>
<p>GCC 27</p>	<p>Currency of Payment:</p> <p>All the payment to be released to the contractor/Bidder shall be in Pakistani Rupees.</p>
<p>GCC 28</p>	<p>Payment terms:</p> <p>Payment will be made to the Bidder against the procured Goods and services according to the actual invoice or running bills submitted by the Bidder against the services provided within the time given in the conditions of the contract.</p>

GCC 29**Identifying Defects:**

The Authority reserves the right at any time to inspect the premises of the provider to inspect the goods and monitor the goods being provided.

Inspections & Tests Requirements

For being Brand New, bearing relevant reference numbers of the equipment (Certificate from supplier)

For Physical Fitness having No Damages (Certificate from supplier)

For the Country of Origin as quoted by the Supplier (Certificate from manufacturer)

For conformance to specifications and performance parameters, through Prior to delivery inspection (Inspection Report by Inspection Team)

For successful operation at site after complete installation, testing and commissioning of the equipment (Installation, Testing and Commissioning Report by Inspection Team)

Delivery & Documents

Copies of the Supplier's invoice showing Goods' description, quantity, unit price, and total amount;

Original and two copies of the usual transport document (for example, a negotiable bill of lading, a non-negotiable sea waybill, an inland waterway document, an air waybill, a railway consignment note, a road consignment note, or a multimodal transport document) which the buyer may require to take the goods;

Copies of the packing list identifying contents of each package;

Insurance Certificate;

Manufacturer's or Supplier's Valid Warranty Certificate;

Inspection Certificate issued by the Nominated Inspection Agency (if any), and the Supplier's Factory Inspection Report;

Certificate of Origin.

The above documents would be required even if the equipment has already been imported and is available with the supplier ex-stock

Following is the guidance for Dispute Resolution

1. If any dispute of any kind whatsoever shall arise between the Authority and the Bidder in connection with or arising out of the Contract, including without prejudice to the generality of foregoing, any question regarding its existence, validity, termination and the execution of the Contract – whether during developing phase or after their completion and whether before or after the termination, abandonment or breach of the Contract – the parties shall seek to resolve any such dispute or difference by mutual diligent negotiations in good faith within 14 (fourteen) days following a notice sent by one Party to the other Party in this regard.
2. At future of negotiation the dispute shall be resolved through mediation and mediator shall be appointed with the mutual consent of the both parties.
3. At the event of failure of mediation to resolve the dispute relating to this contract such dispute shall finally be resolved through binding Arbitration by sole arbitrator in accordance with Arbitration Act 1940. The arbitrator shall be appointed by mutual consent of the both parties. The Arbitration shall take place in Islamabad, Pakistan and proceedings will be conducted in English language.
4. The cost of the mediation and arbitration shall be shared by the parties in equal proportion however the both parties shall bear their own costs and lawyer's fees regarding their own participation in the mediation and arbitration. However, the Arbitrator may make an award of costs upon the conclusion of the arbitration making any party to the dispute liable to pay the costs of another party to the dispute.
5. Arbitration proceedings as mentioned in the above clause regarding resolution of disputes may be commenced prior to, during or after completion of the contract.

Notwithstanding any reference to the arbitration herein, the parties shall continue to perform their respective obligations under the Contract unless they otherwise agree that the Authority shall pay the Bidder any monies due to the Bidder.

Arbitrator's fee:

The fee shall be specified in Pak Rupees, as determined by the Arbitrator, which shall be shared equally by both parties.

Appointing Authority for Arbitrator:

By the Mutual Consent or in accordance with the provisions of Arbitration Act, 1940, in case the parties fail to reach a consensus on the name of sole arbitrator, any party may submit an application to the Chief Justice Islamabad High Court for appointment of sole arbitrator. The Chief Justice IHC may appoint a former judge of any High Court or Supreme Court as the sole arbitrator to resolve the dispute between the parties.

Rules of procedure for arbitration proceedings:

Any dispute between the Authority and a Bidder who is a national of the Islamic Republic of Pakistan arising in connection with the present Contract shall be referred to adjudication or arbitration in accordance with the laws of the Islamic Republic of Pakistan including Arbitration Act 1940, however above provision shall prevail in referring the case to the Arbitrator.

Place of Arbitration and Award:

The arbitration shall be conducted in English language and place of arbitration shall be at



Bid Securing Declaration

Form 9: Bid Securing Declaration

Date: *[insert date (as day, month and year)]*

Bid No.: **P36011**

To: **PNSC (CSR), Actg. General Manager Finance FINANCE DEPARTMENT, 12TH FLOOR, PNSC BUILDING, M.T KHAN ROAD, KARACHI**

We, the undersigned, declare that:

We understand that, according to your conditions, Bids must be supported by a Bid Securing Declaration.

We accept that we will be blacklisted and henceforth cross debarred for participating in respective category of public procurement proceedings for a period of (not more than) six months, if fail to abide with a bid securing declaration, however without indulging in corrupt and fraudulent practices, if we are in breach of our obligation(s) under the Bid conditions, because we:

1. have withdrawn or modified our Bid during the period of Bid Validity specified in the Form of Bid;
2. Disagreement to arithmetical correction made to the Bid price; or
3. having been notified of the acceptance of our Bid by the Procuring Agency during the period of Bid Validity, (i) failure to sign the contract if required by Procuring Agency to do so or (ii) fail or refuse to furnish the Performance Security or to comply with any other condition precedent to signing the contract specified in the Bidding Documents.

We understand this Bid Securing Declaration shall expire if we are not the successful

Bidder, upon the earlier of (i) our receipt of your notification to us of the name of the successful Bidder; or (ii) twenty-eight (28) days after the expiration of our Bid.



Contract Form

SECTION IX: CONTRACT FORMS

THIS AGREEMENT made the _____ day of _____ 20____ between **PNSC (CSR), Actg. General Manager Finance FINANCE DEPARTMENT, 12TH FLOOR, PNSC BUILDING, M.T KHAN ROAD, KARACHI**

(hereinafter called “the Procuring Agency”) of the one part and *[name of Bidder]* of *[city and country of Bidder]* (hereinafter called “the Bidder”) of the other part:

WHEREAS the Procuring Agency invited Bids for provision of goods, viz., **REPAIR RENOVATION AND REFURBISHMENT OF ADMIN BLOCK, MEDICAL CENTER, PARADE GROUND, SPORTS COMPLEX, SWIMMING POOL & EXAMINATION HALL AT PAKISTAN MARINE ACADEMY (P36011)** and has accepted a Bids by the Bidder for the provision of Goods in the sum of *[contract price in words and figures]* (hereinafter called “the Contract Price”).

NOW THIS CONTRACT WITNESSETH AS FOLLOWS:

1. In this Contract words and expressions shall have the same meanings as are respectively assigned to them in the Conditions of Contract referred to.

2. The following documents shall be deemed to form and be read and construed as part of this Contract, In the event of any ambiguity or conflict between the Contract Documents listed below, the order of precedence shall be the order in which the Contract Documents are listed below:-

1. This form of Contract;
2. the Form of Bids and the Price Schedule submitted by the Bidder;
3. the Schedule of Requirements;
4. the Technical Specifications;
5. the Special Conditions of Contract;
6. the General Conditions of the Contract;
7. the Procuring Agency’s Letter of Acceptance; and
8. *[add here: any other documents]*

3. In consideration of the payments to be made by the Procuring Agency to the Bidder as hereinafter mentioned, the Bidder hereby covenants with the Procuring Agency to provide the Goods related services and to remedy defects therein in conformity in all respects with the provisions of the Contract.

4. The Procuring Agency hereby covenants to pay the Bidder in consideration of the provision of Goods and the remedying of defects therein, the Contract Price or such other sum as may become payable under the provisions of the contract at the times and in the manner prescribed by the contract.

IN WITNESS whereof the parties hereto have caused this Contract to be executed in accordance with their respective laws the day and year first above written.

Signed, sealed, delivered by _____ the _____ (for the Procuring Agency)

Witness to the signatures of the Procuring Agency:

.....

Signed, sealed, delivered by _____ the _____ (for the Procuring Agency)

Witness to the signatures of the Bidder:





Integrity Pact

Integrity Pact

DECLARATION OF FEES, COMMISSION AND BROKERAGE ETC. PAYABLE BY THE SUPPLIERS OF GOODS, SERVICES & WORKS IN CONTRACTS WORTH RS.10.00 MILLION OR MORE

Contract Number: Contract Value: Contract Title:

Dated:

[Name of Supplier] hereby declares that it has not obtained or induced the procurement of any contract, right, interest, privilege or other obligation or benefit from Government of Pakistan or any administrative subdivision or agency thereof or any other entity owned or controlled by it (GoP) through any corrupt business practice.

Without limiting the generality of the foregoing [Name of Supplier] represents and warrants that it has fully declared the brokerage, commission, fee etc. paid or payable to anyone and not given or agreed to give and shall not give or agree to give to anyone within or outside Pakistan either directly or indirectly through any natural or juridical person, including its affiliate, agent, associate, broker, consultant, director, promoter, shareholder, sponsor or subsidiary, any commission, gratification, bribe, finder's fee or kickback, whether described as consultations fee or otherwise, with the object of obtaining or inducing the procurement of a contract, right, interest, privilege or other obligation or benefit in whatsoever form from GoP, except that which has been expressly declared pursuant hereto.

[Name of Supplier] certifies that it has made and will make full disclosure of all agreements and arrangements with all persons in respect of or related to the transaction with GoP and has not taken any action or will not take any action to circumvent the above declaration, representative or warranty.

[Name of Supplier] accepts full responsibility and strict liability for making and false declaration, not making full disclosure, misrepresenting fact or taking any action likely to defeat the purpose of this declaration, representation and warranty. It agrees that any contract, right interest, privilege or other obligation or benefit obtained or procured as aforesaid shall, without prejudice to any other right and remedies available to GoP under any law, contract or other instrument, be voidable at the option of GoP.

Notwithstanding any rights and remedies exercised by GoP in this regard, [Name of Supplier] agrees to indemnify GoP for any loss or damage incurred by it on account of its corrupt business practices and further pay compensation to GoP in an amount equivalent to ten times the sum of any commission, gratification, bribe, finder's fee or kickback given by [Name of Supplier] as aforesaid for the purpose of obtaining or inducing the procurement of any contract, right, interest, privilege or other obligation or benefit in whatsoever form from GoP.



Performance Guarantee Form

Performance Guarantee Form

To: PNSC (CSR), Actg. General Manager Finance FINANCE DEPARTMENT, 12TH FLOOR, PNSC BUILDING, M.T KHAN ROAD, KARACHI

WHEREAS *[name of Bidder]* (hereinafter called “the Bidder”) has undertaken, in pursuance of Contract No. *[reference number of the contract]* dated *[insert date]* for provision of Goods (hereinafter called “the Contract”).

AND WHEREAS it has been stipulated by you in the said Contract that the Bidder shall furnish you with a Bank Guarantee by a reputable bank for the sum specified therein as security for compliance with the Bidder’s performance obligations in accordance with the Contract.

AND WHEREAS we have agreed to give the Bidders guarantee:

THEREFORE, WE hereby affirm that we are Guarantors and responsible to you, on behalf of the Bidder, up to a total of *[amount of the guarantee in words and figures]*, and we undertake to pay you, upon your first written demand declaring the Bidder to be in default under the Contract and without cavil or argument, any sum or sums within the limits of *[amount of guarantee]* as aforesaid, without your needing to prove or to show grounds or reasons for your demand or the sum specified therein.

This guarantee is valid until the: *[insert date]*

Signature and seal of the Guarantors

[name of bank or financial institution]

[address]

[date]



Annexure

Drawings

Project Drawings

Information (Read-Only)

See Form Under Additional Forms and Documents: **Drawings** (page number: 100)

Technical Specification

Detailed Technical Specification of project

Information (Read-Only)

See Form Under Additional Forms and Documents: **Technical Specification** (page number: 125)

BOQ of Works

Detailed BOQ

Financial Submission (Vendor)

Document Required

See Form Under Additional Forms and Documents: **BOQ of Works** (page number: 199)

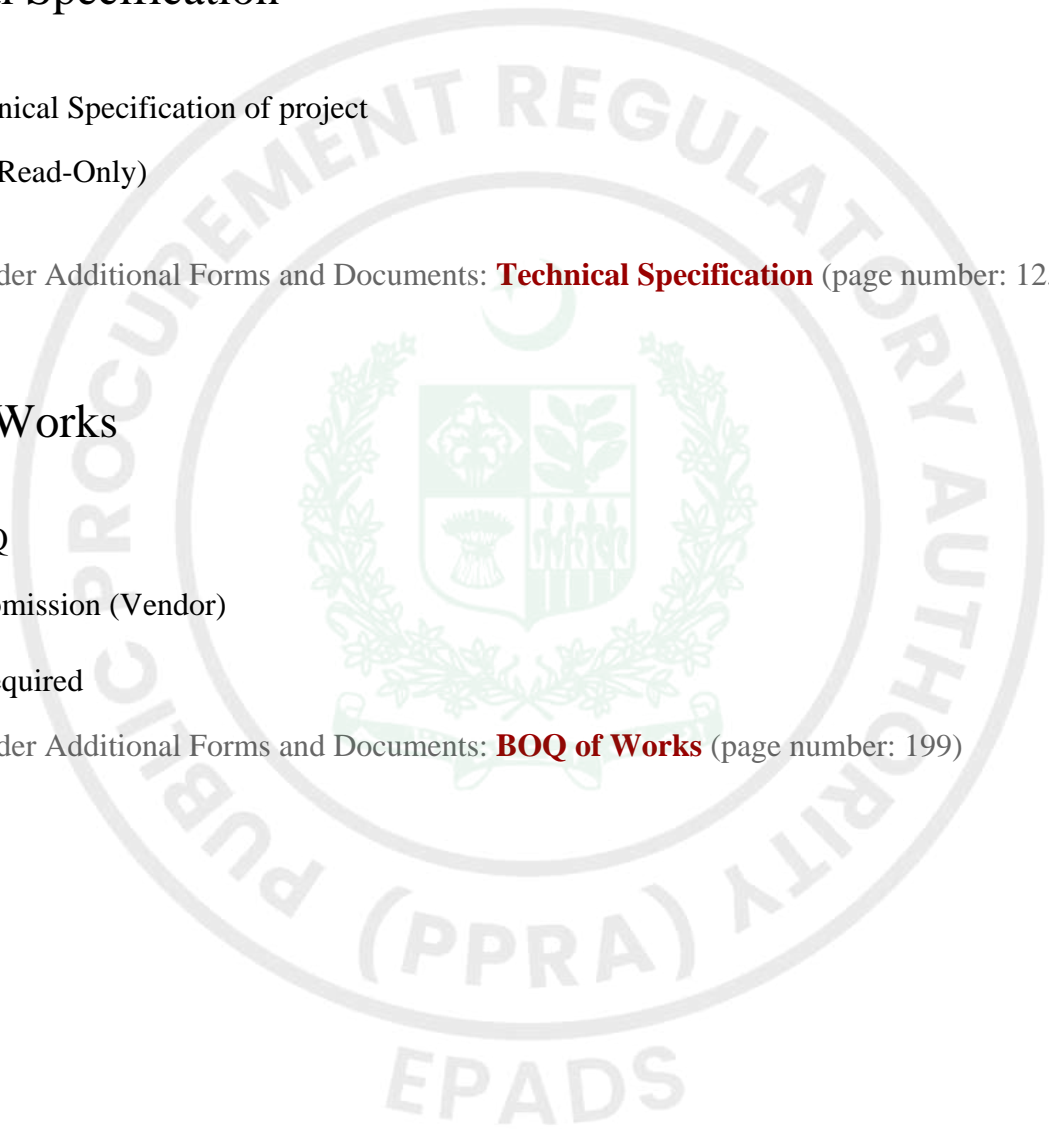



Procurement Forms

Past Experience and Completed Contracts

See Form Under Additional Forms and Documents: **Past Experience and Completed Contracts** (page number: 211)

Historical Contract Non-Performance, and Pending Litigation and Litigation History

See Form Under Additional Forms and Documents: **Historical Contract Non-Performance, and Pending Litigation and Litigation History** (page number: 212)

Current Contracts and Their Progress

See Form Under Additional Forms and Documents: **Current Contracts and Their Progress** (page number: 214)

Financial Capacity and Net Worth Evaluation Form

See Form Under Additional Forms and Documents: **Financial Capacity and Net Worth Evaluation Form** (page number: 215)

Average Annual Turnover

See Form Under Additional Forms and Documents: **Average Annual Turnover** (page number: 217)





Additional Forms and Documents

CLIENT

MARINE ACADEMY

PROJECT

EXAMINATION HALL

(AS BUILT DRAWINGS)

PREPARED BY

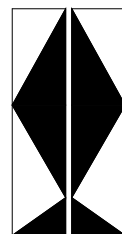

ESS - I - AAR
PLANNING, ENGINEERING & SERVICES CONSULTANTS
SUITE NO. 314 , 3 - RD . FLOOR MASHRIQ CENTRE
SIR SHAH SULAIMAN ROAD , GULSHAN - E - IQBAL
BLOCK NO. 14 , KARACHI , P. O. BOX NO. 7608
PHONE NO. 4852589 FAX NO. (92 - 21) 4941059

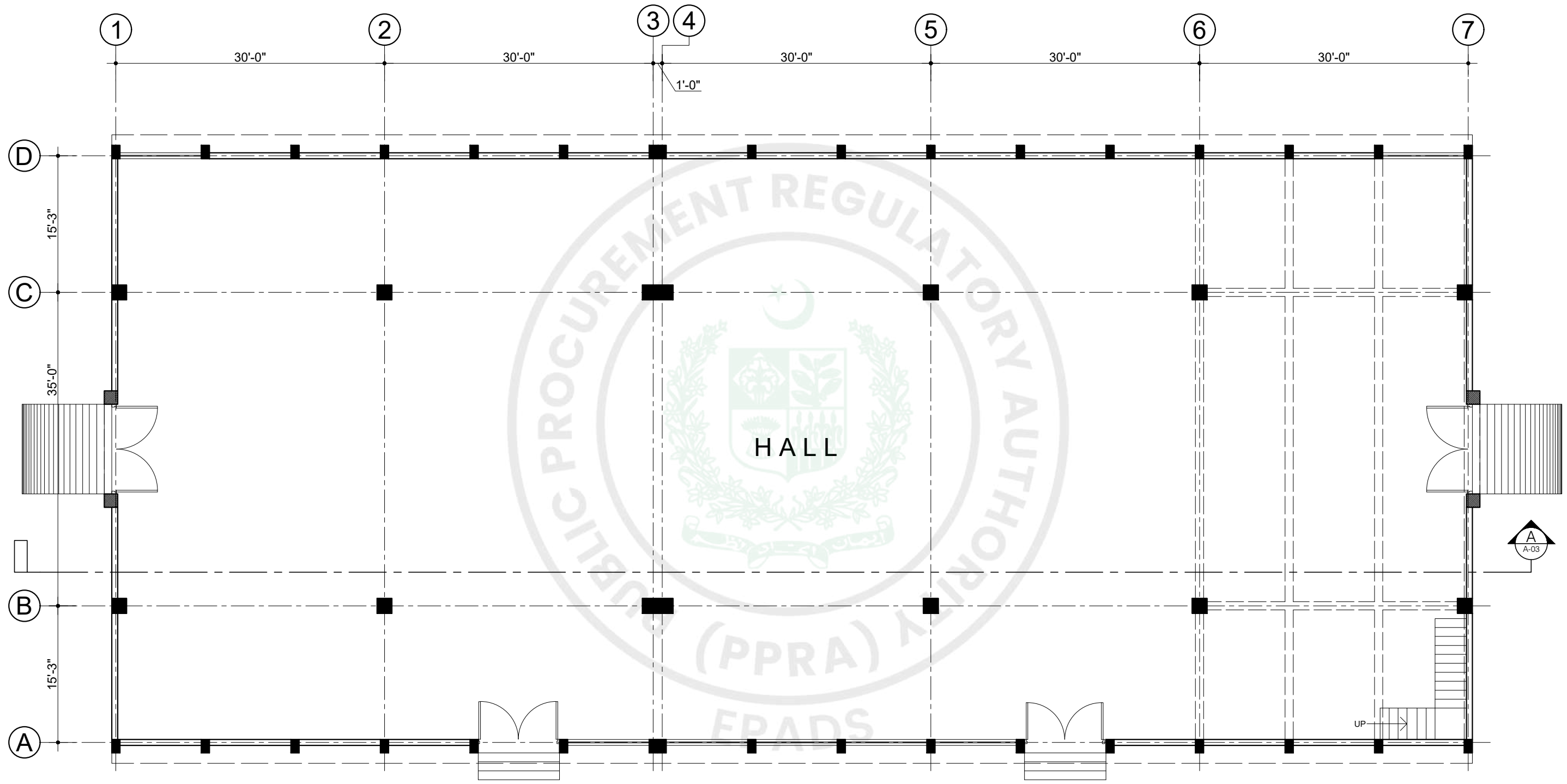

GROUND FLOOR PLAN

COVERED AREA = 10052.00 square ft.

Client MARINE ACADEMY	Job SIMULATOR BUILDING	 ESS-I-AAR PLANNING, ENGINEERING & SERVICES CONSULTANTS Suite No. 314, 3rd Floor, Mashriq Centre, Sir Shah Sulaiman Road, Gulshan-e-Iqbal, Block 14, Karachi. P.O. Box 7608 Ph. 4852589 Fax (92-21)4941059	TITLE: Ground Floor Plan Ref. Rev.	DATE: DRAWN: M.A	COM. LOCATION. SHEET REF. ARCH A=01
---------------------------------	----------------------------------	---	---	----------------------------	--

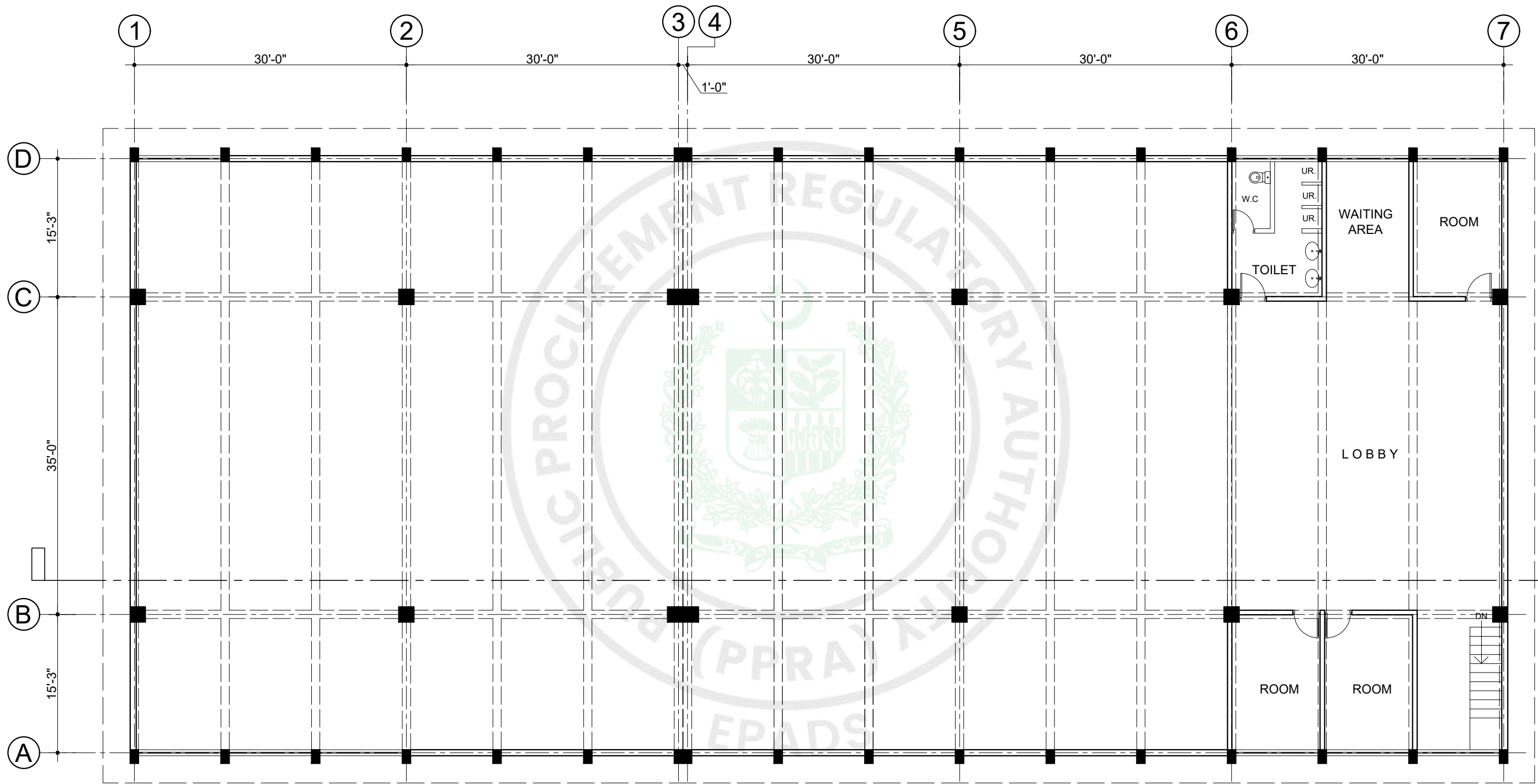

MEZZANINE FLOOR PLAN

Client MARINE ACADEMY	Job SIMULATOR BUILDING	 ESS-I-AAR PLANNING, ENGINEERING & SERVICES CONSULTANTS Suite No. 314, 3rd Floor, Mashriq Centre, Sir Shah Sulaiman Road, Gulshan-e-Iqbal, Block 14, Karachi. P.O. Box 7608 Ph. 4852589 Fax (92-21)4941059	<table border="1"> <tr> <td>TITLE: Mezzanine Floor Plan</td> <td>DATE:</td> <td>COM. LOCATION:</td> </tr> <tr> <td>Ref. Rev.</td> <td>DRAWN: M.A</td> <td>SHEET REF. ARCH A=02</td> </tr> </table>	TITLE: Mezzanine Floor Plan	DATE:	COM. LOCATION:	Ref. Rev.	DRAWN: M.A	SHEET REF. ARCH A=02
TITLE: Mezzanine Floor Plan	DATE:	COM. LOCATION:							
Ref. Rev.	DRAWN: M.A	SHEET REF. ARCH A=02							

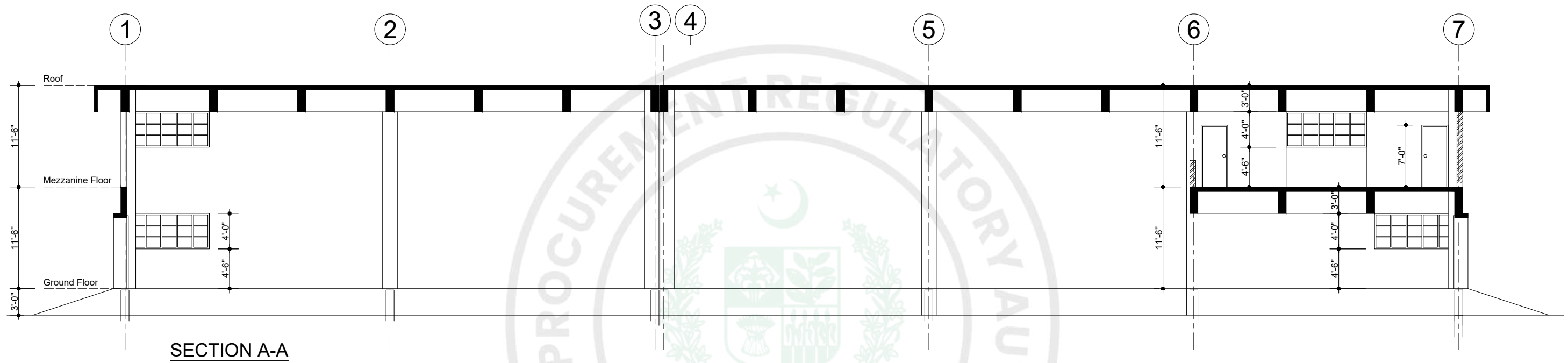

SECTION A-A

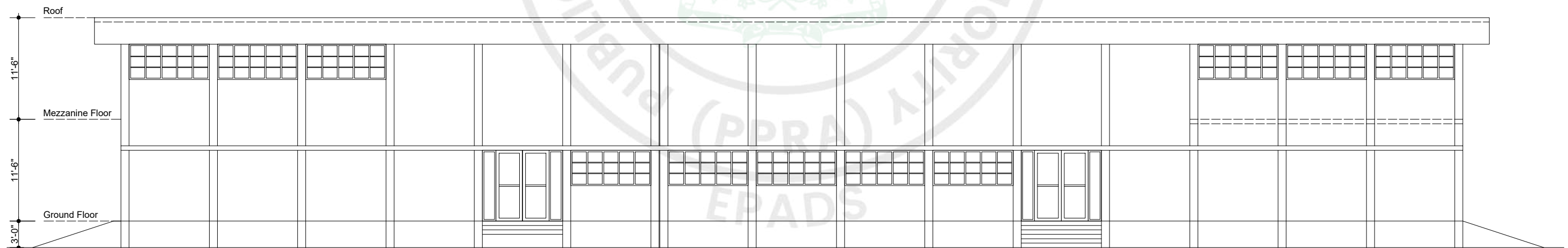

FRONT ELEVATION

Client MARINE ACADEMY	Job EXAMINATION HALL	 ESS-I-AAR PLANNING, ENGINEERING & SERVICES CONSULTANTS Suite No. 314, 3rd Floor, Mashriq Centre, Sir Shah Sulaiman Road, Gulshan-e-Iqbal, Block 14, Karachi. P.O. Box 7608 Ph. 4852589 Fax (92-21)4941059	TITLE: Section & Elevation Ref. Rev.	DATE: _____ DRAWN: M.A	COM. LOCATION: _____ SHEET REF. ARCH A=03
---------------------------------	--------------------------------	---	---	---------------------------------	---

CLIENT

MARINE ACADEMY

PROJECT

EXAMINATION HALL

TITLE

REHABILITATION DRAWING'S

PREPARED BY

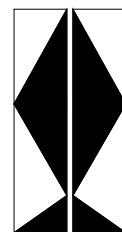

ESS - I - AAR

PLANNING, ENGINEERING & SERVICES CONSULTANTS
SUITE NO. 314, 3 - RD. FLOOR MASHRIQ CENTRE
SIR SHAH SULAIMAN ROAD, GULSHAN - E - IQBAL
BLOCK NO. 14, KARACHI, P. O. BOX NO. 7608
PHONE NO. 4852589 FAX NO. (92-21) 4941059

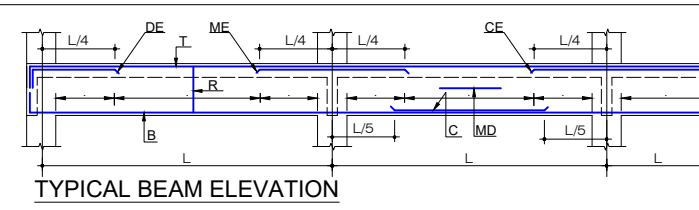
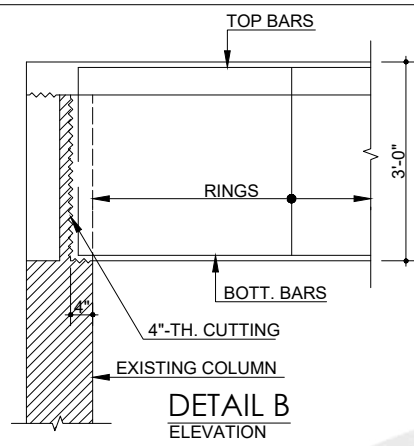
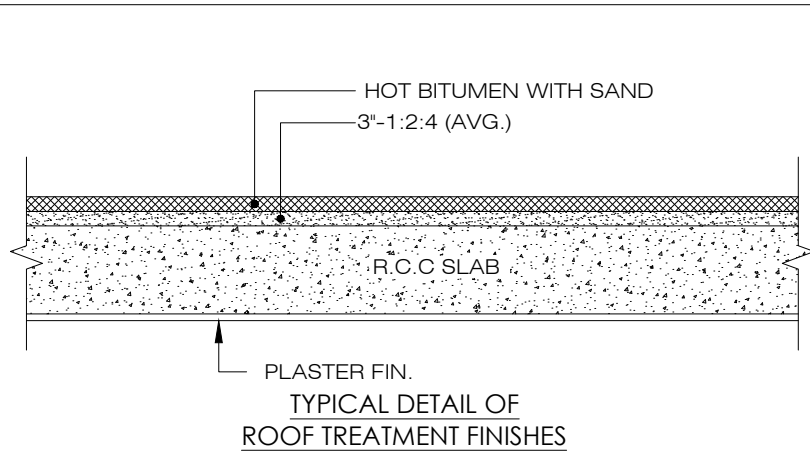

SCHEDULE OF NEW BEAM									
BEAM NO.	BEAM SIZES	T	B	C	DE	CE	ME	MD	RINGS
B-4	12"x36"	4-3/4"Ø	3-3/4"Ø	3-5/8"Ø	-	-	-	-	3/8"Ø@7"x10"c/c
B-5	12"x36"	3-3/4"Ø	3-3/4"Ø	3-5/8"Ø	-	-	-	-	3/8"Ø@7"x10"c/c
B-6	12"x36"	2-3/4"Ø	3-3/4"Ø	2-1/2"Ø	2-3/4"Ø	-	-	-	3/8"Ø@7"x10"c/c
B-11	12"x36"	3-3/4"Ø	3-3/4"Ø	3-5/8"Ø	-	-	-	-	3/8"Ø@7"x10"c/c
B-12	12"x36"	3-3/4"Ø	3-3/4"Ø	3-5/8"Ø	-	-	-	-	3/8"Ø@7"x10"c/c
B-13	12"x36"	2-3/4"Ø	3-3/4"Ø	2-1/2"Ø	2-3/4"Ø	-	-	-	3/8"Ø@7"x10"c/c
B-14	12"x36"	3-3/4"Ø	3-3/4"Ø	3-5/8"Ø	-	-	-	-	3/8"Ø@7"x10"c/c
B-15	12"x36"	4-3/4"Ø	3-3/4"Ø	3-5/8"Ø	-	-	-	-	3/8"Ø@7"x10"c/c

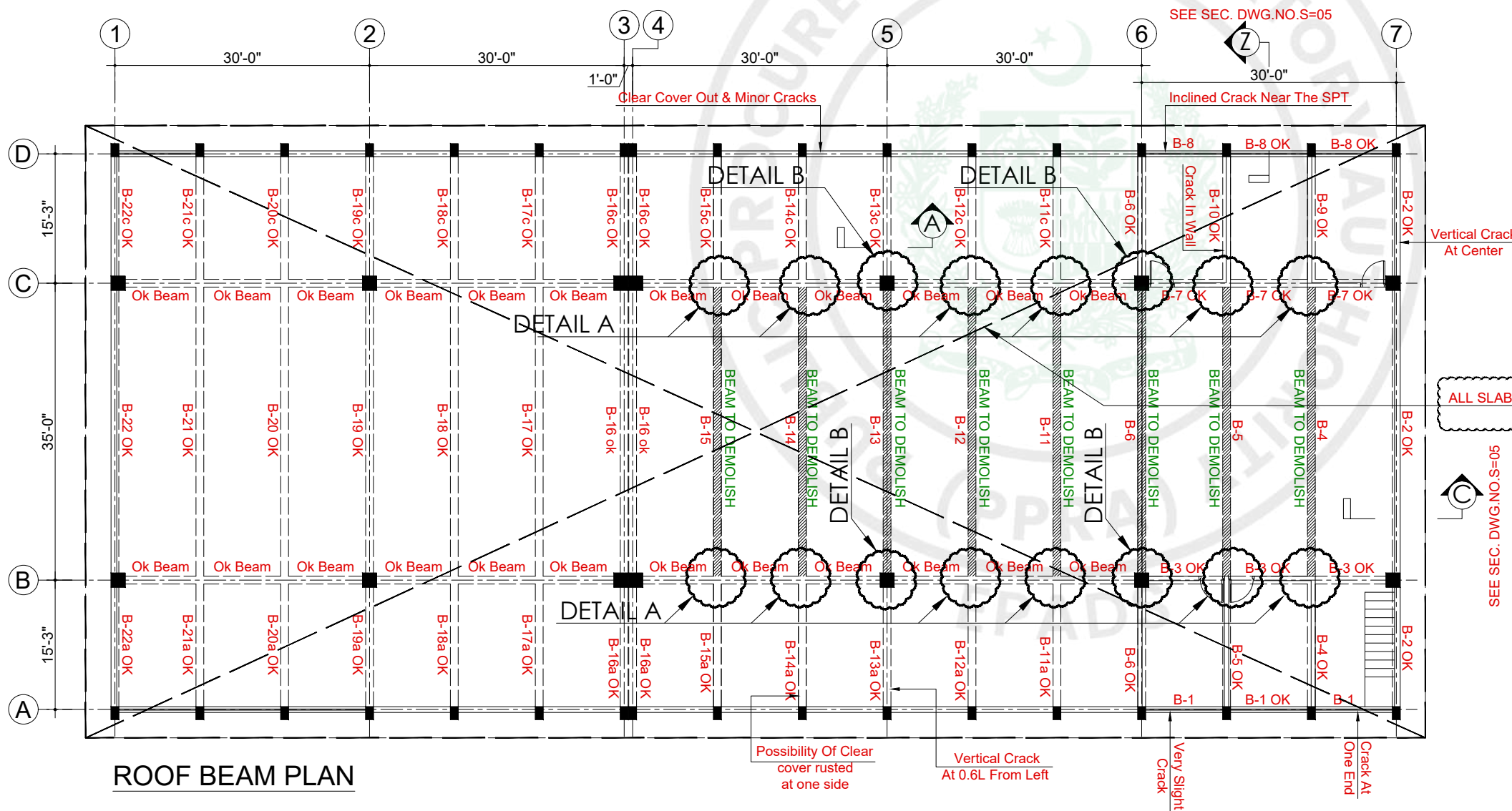
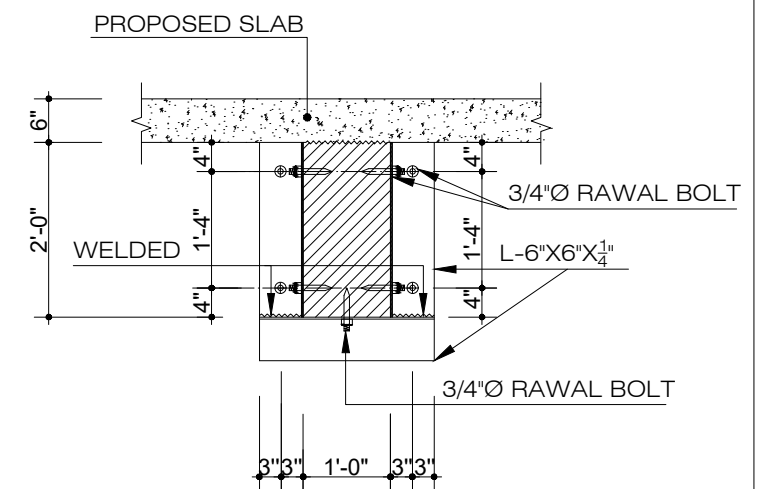
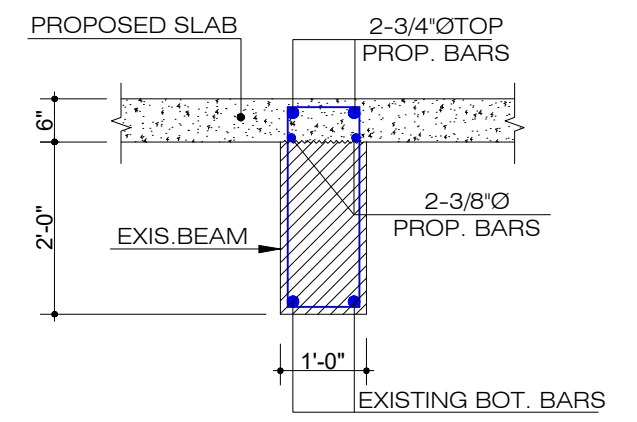

ALL SLAB TO BE REMOVE

SEE SEC. DWG. NO. S=05

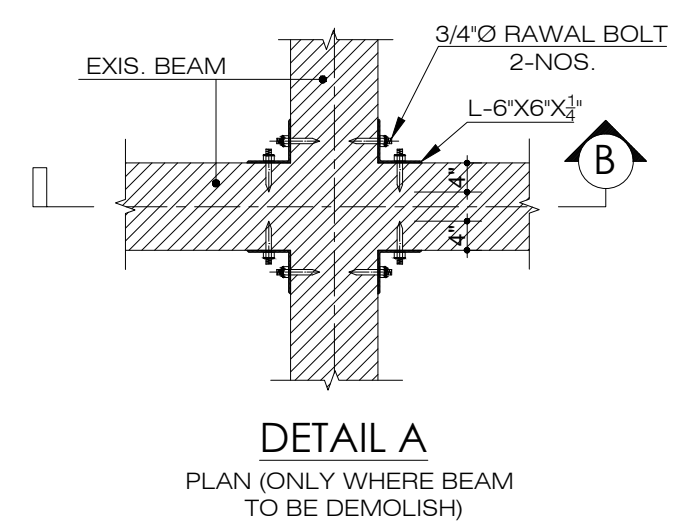

Client	Job	ESS-I-AAR PLANNING, ENGINEERING & SERVICES CONSULTANTS Suite No. 314, 3rd Floor, Mashriq Centre, Sir Shah Sulaiman Road, Gulshan-e-Iqbal, Block 14, Karachi. P.O. Box 7608 Ph. 4852589 Fax (92-21)4941059	TITLE: REHABILITATION DETAILS	DATE: 09-10-24	COM. LOCATION.
MARINE ACADEMY	EXAMINATION HALL		Ref. Rev.	DRAWN: M.A	SHEET REF. STR. S=01

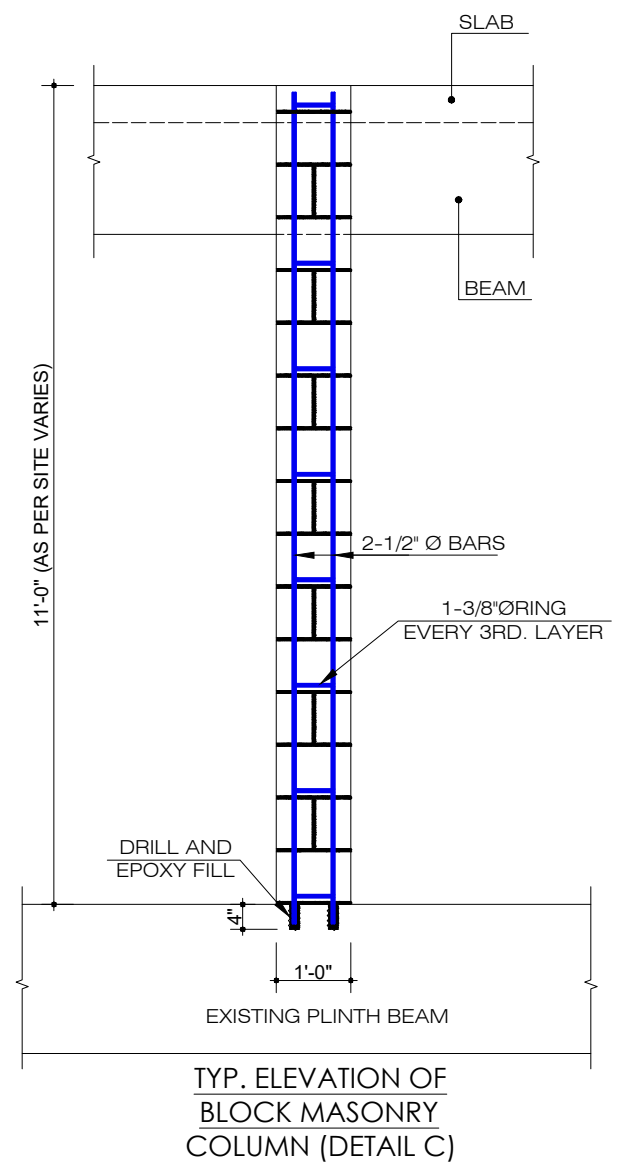
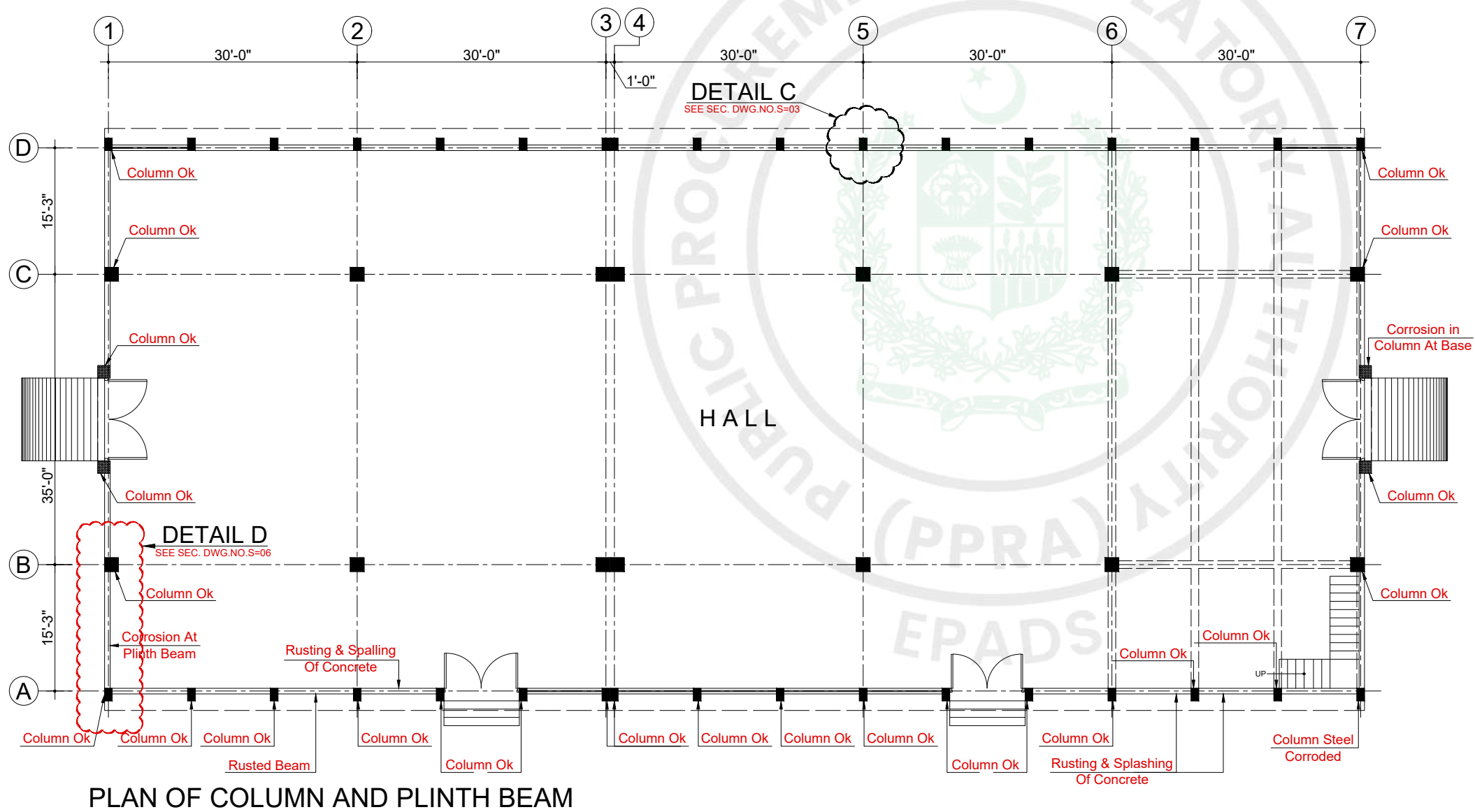
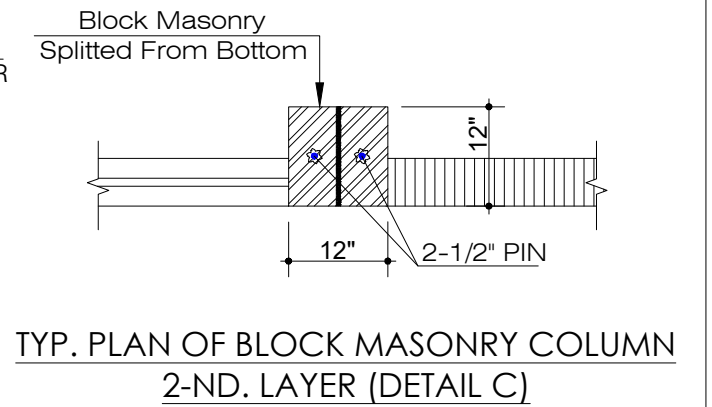
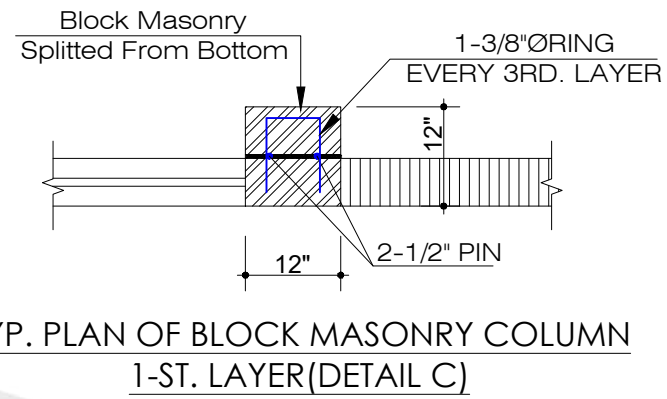
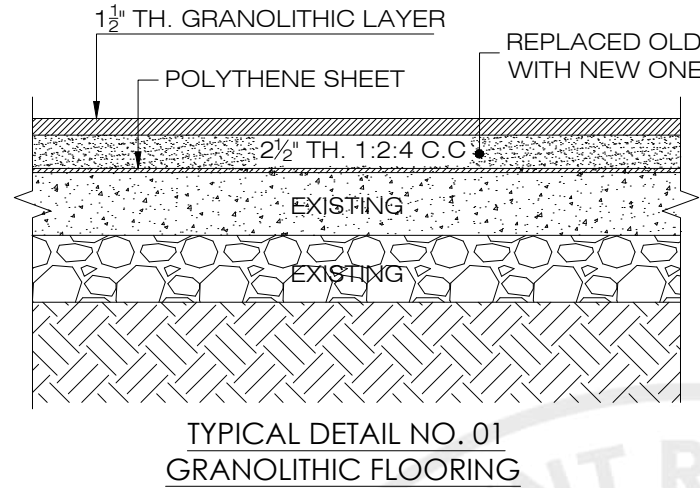
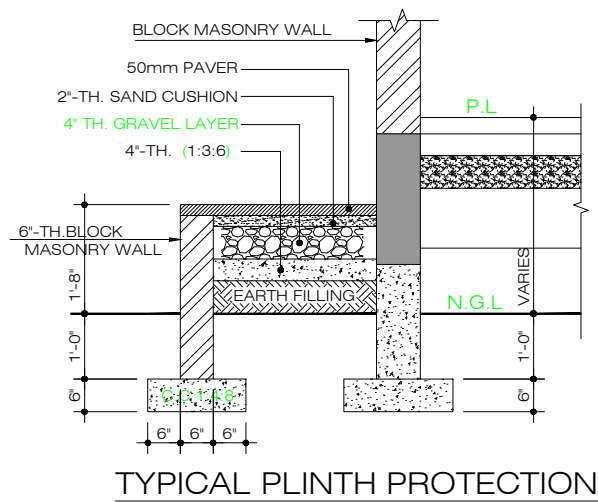

Client	Job	 ESS-I-AAR PLANNING, ENGINEERING & SERVICES CONSULTANTS Suite No. 314, 3rd Floor, Mashriq Centre, Sir Shah Sulaiman Road, Gulshan-e-Iqbal, Block 14, Karachi. P.O. Box 7608 Ph. 4852589 Fax (92-21)4941059	TITLE:	DATE: 09-10-24	COM. LOCATION.
MARINE ACADEMY	EXAMINATION HALL		REHABILITATION DETAILS	DRAWN:	SHEET REF.
			M.A	STR.	S=02

NOTE :-

- 1---- OPEN CRACKS
- 2---- WIRE BRUSH AND REMOVE SCALES ON REBARS
- 3---- CUTTING THE COLUMN AS SHOWN DWG. AS PER MANUFACTURES SPECIFICATION,
- 4---- CHECK THE SIZE OF MAIN BAR IF REDUCED ADD BAR FOR A LENGTH 3' ABOVE & BELOW CRACKED AREA BY WELDING OR BINDING WITH WIRE
- 5---- ALSO ADD RINGS IF NOT IN GOOD CONDITION BY DRILLING & EPOXY
- 6---- APPLY ZINC RICH PRIMER ON BRUSHD REBARS
- 7---- APPLY CHEMICAL GROUT
- 7---- CONCRETE WITH 5000 PSI CONCRETE

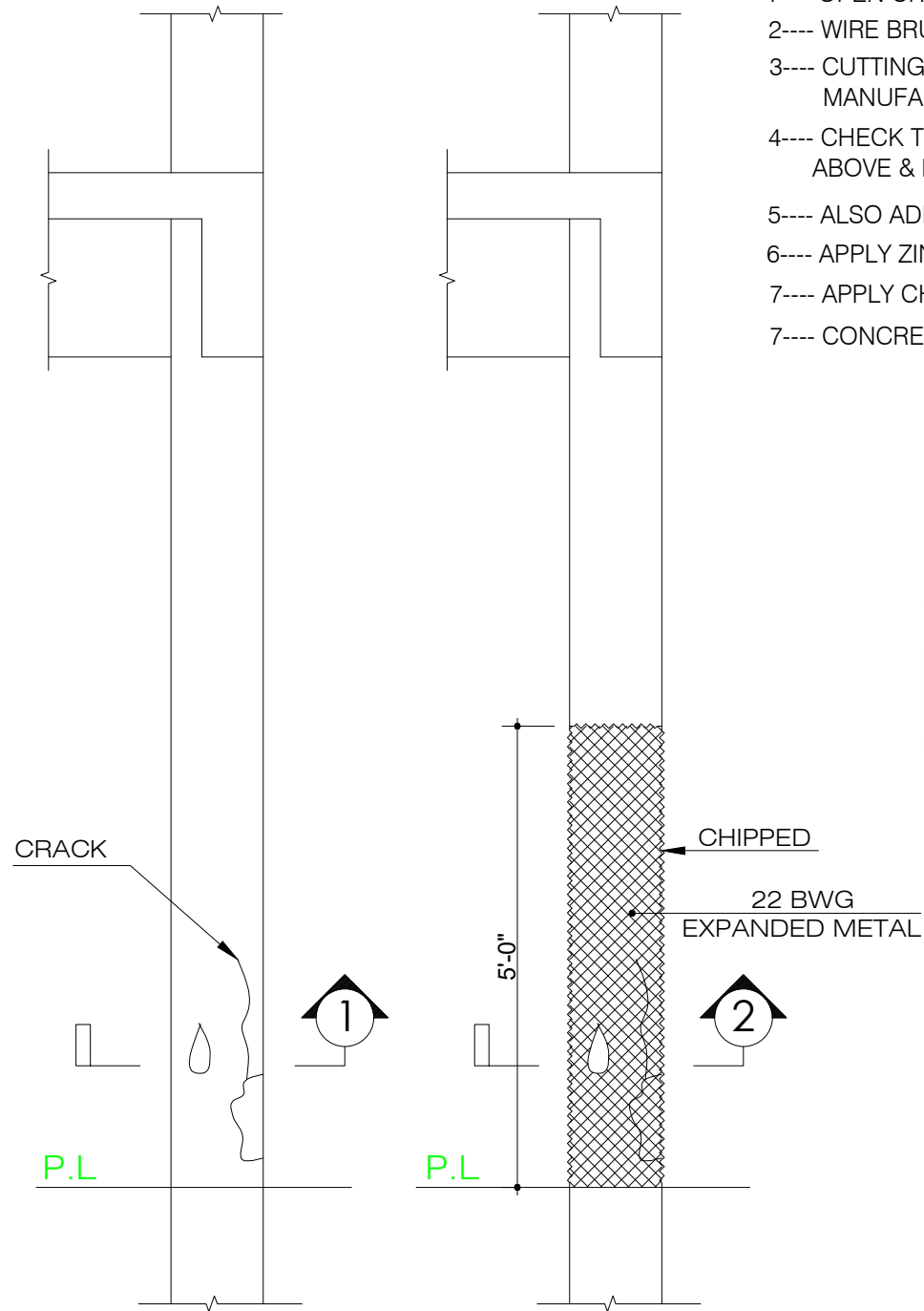

EXIS. COL. ELEVATION NO.1
DETAIL C
REFER SEE SEC. DWG.NO.S=02

REHABILATE COL. ELEVATION
NO.2 DETAIL C

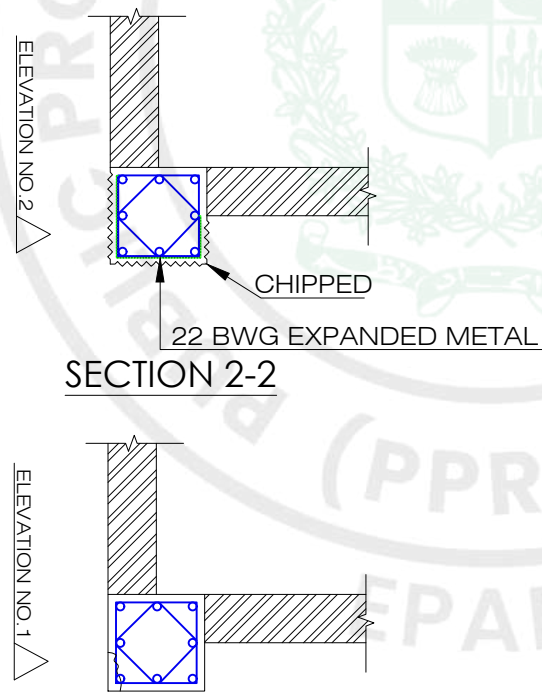

SECTION 1-1

SECTION 2-2

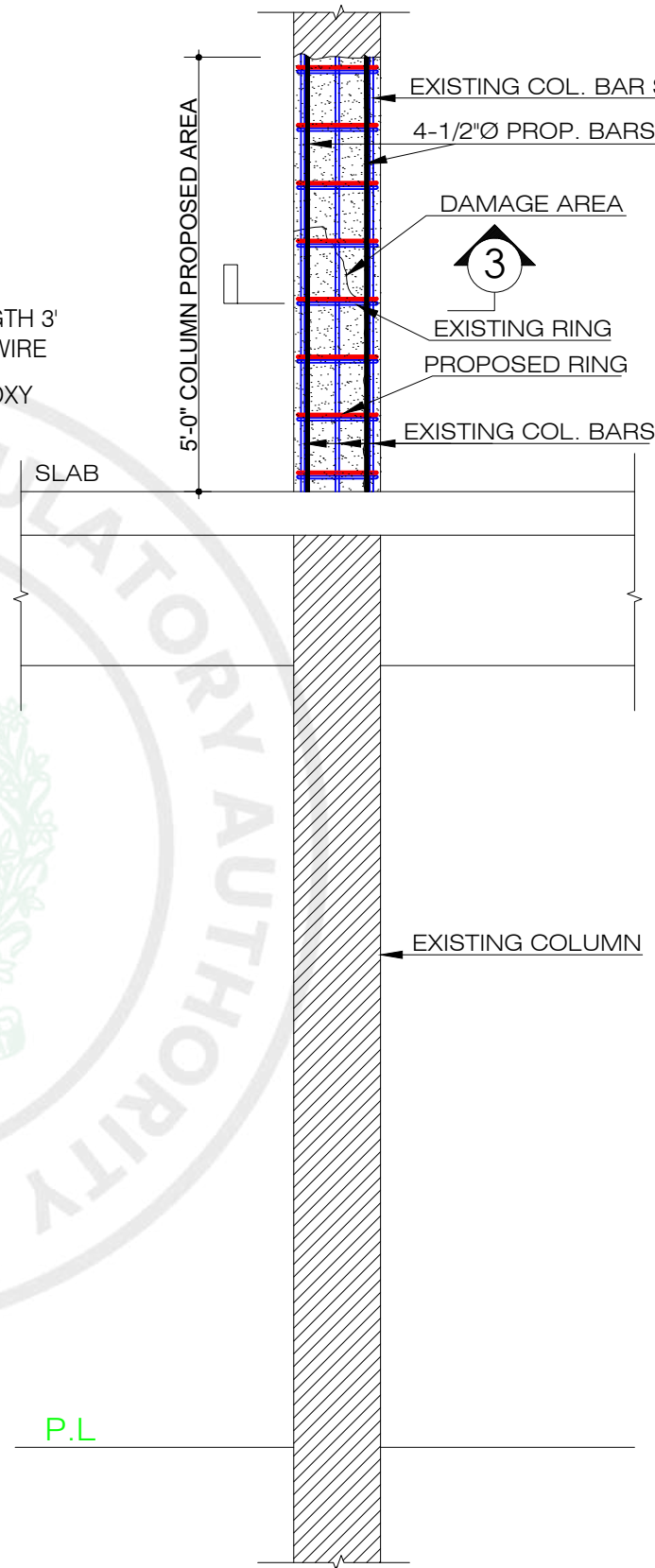

TYP. EXIS. ELEVATION OF
DAMAGE COLUMN

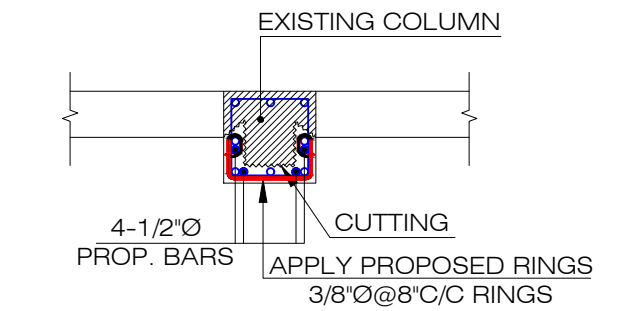

SECTION 3-3
REHEBELIAT DAMAGE COLUMN

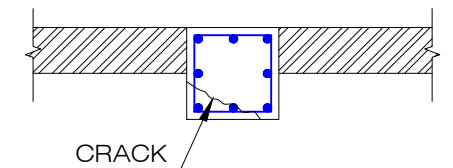

SECTION 3-3
EXIS. CONDITION

Client	Job	 ESS-I-AAR PLANNING, ENGINEERING & SERVICES CONSULTANTS Suite No. 314, 3rd Floor, Mashriq Centre, Sir Shah Sulaiman Road, Gulshan-e-Iqbal, Block 14, Karachi. P.O. Box 7608 Ph. 4852589 Fax (92-21)4941059	TITLE: REHABILATION DETAILS	DATE: 09-10-24	COM. LOCATION.
MARINE ACADEMY	EXAMINATION HALL		Ref. Rev.	DRAWN: M.A	SHEET REF. STR.

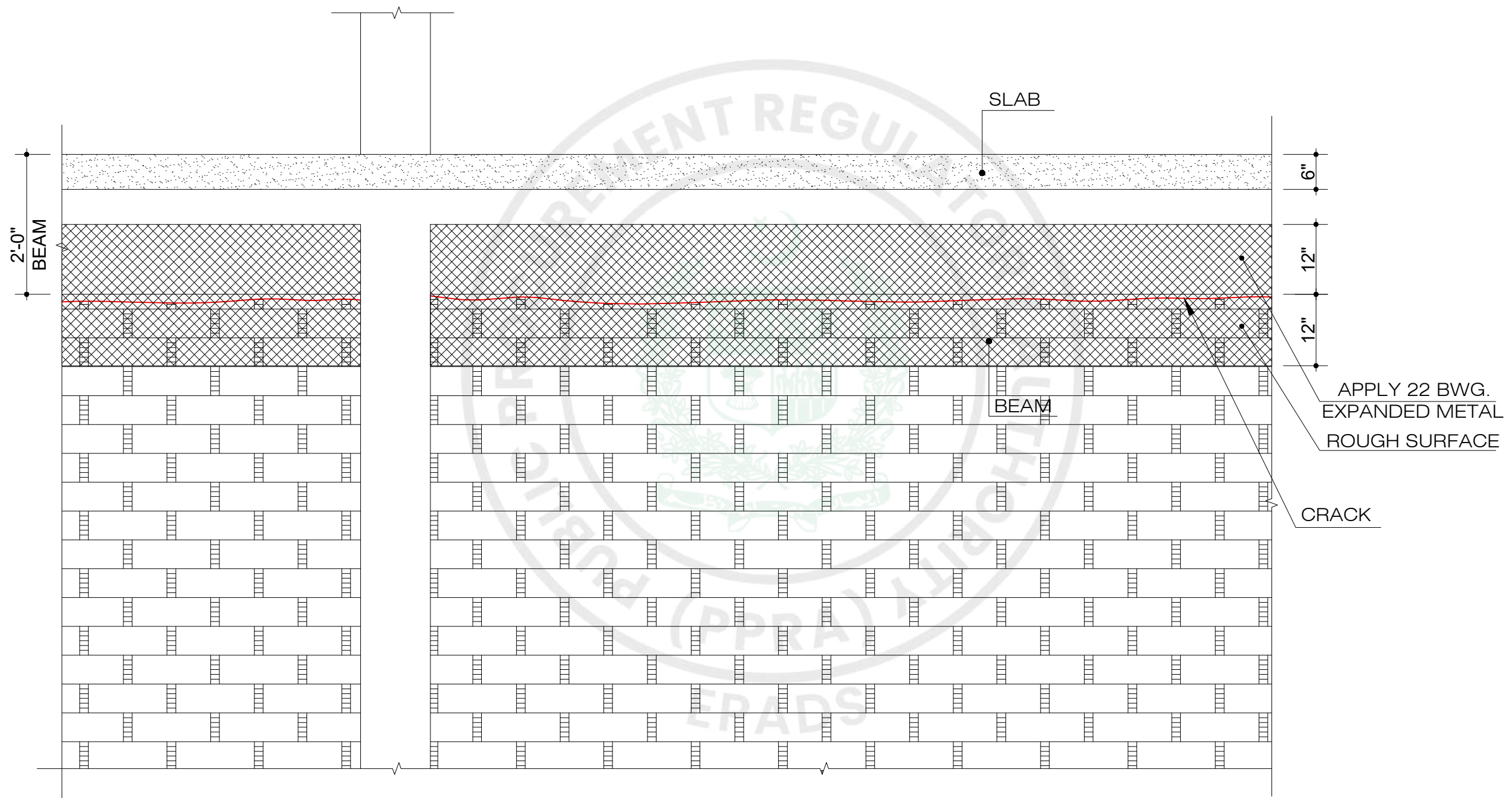

TYPICAL ELEVATION

Client MARINE ACADEMY	Job EXAMINATION HALL	 ESS-I-AAR PLANNING, ENGINEERING & SERVICES CONSULTANTS Suite No. 314, 3rd Floor, Mashriq Centre, Sir Shah Sulaiman Road, Gulshan-e-Iqbal, Block 14, Karachi. P.O. Box 7608 Ph. 4852589 Fax (92-21)4941059	TITLE: REHABILITATION DETAILS Ref. Rev.	DATE: 09-10-24 DRAWN: M.A	COM. LOCATION. SHEET REF. STR. S=04
---------------------------------	--------------------------------	---	--	---------------------------------	---

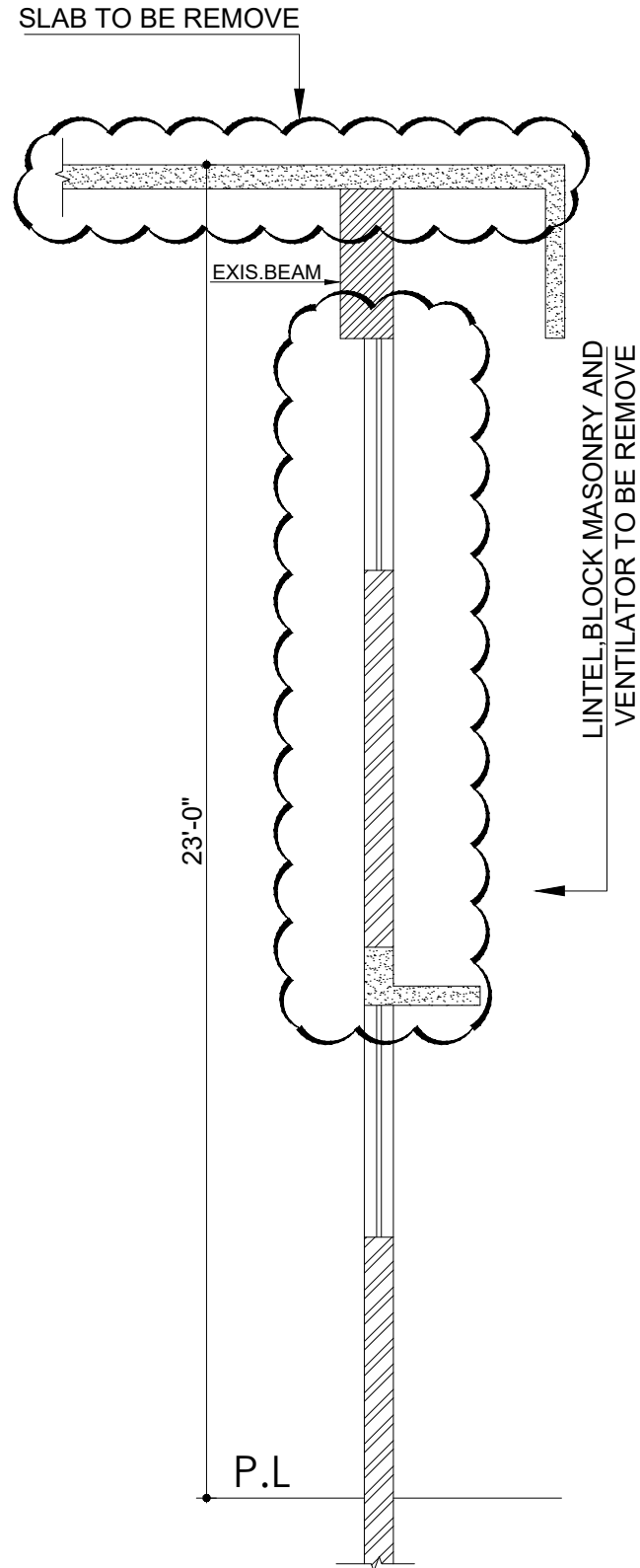

SECTION Z-Z (EXISTING)
REFER SEE SEC. DWG.NO.S=01

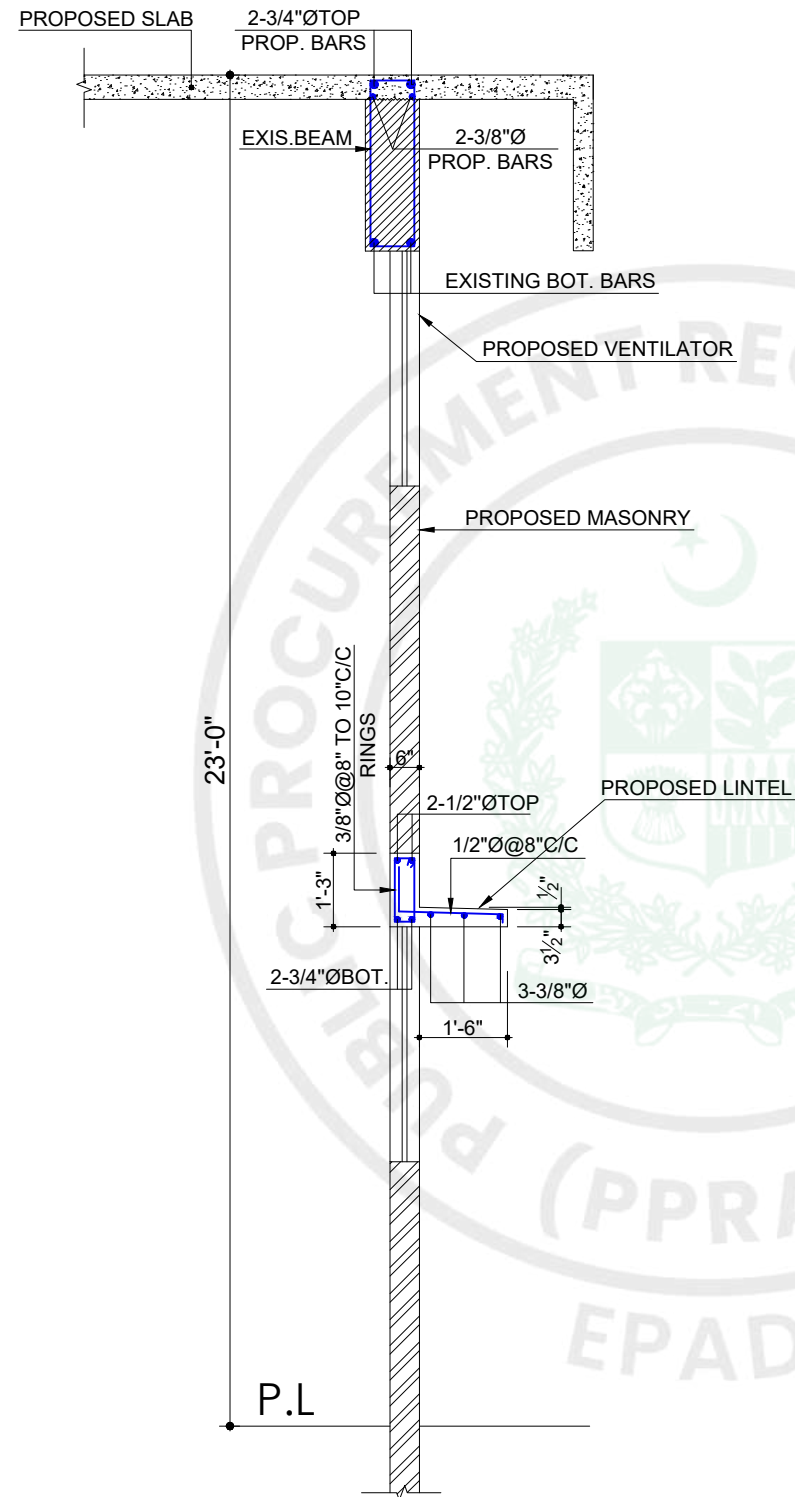

SECTION Z-Z (PROPOSED)
REFER SEE SEC. DWG.NO.S=01

NOTE :-

- 1---- ALL MASONRY AND VENTILATOR NEED TO BE DEMOLISHED
- 2---- ALL LINTELS & PROJECTIONS WILL BE REPLACED WITH NEW ONE
- 3---- NEW MASONRY AND VENTILATOR SHOULD BE INSTALLED PROPERLY AS PER THE DETAIL PROPOSED

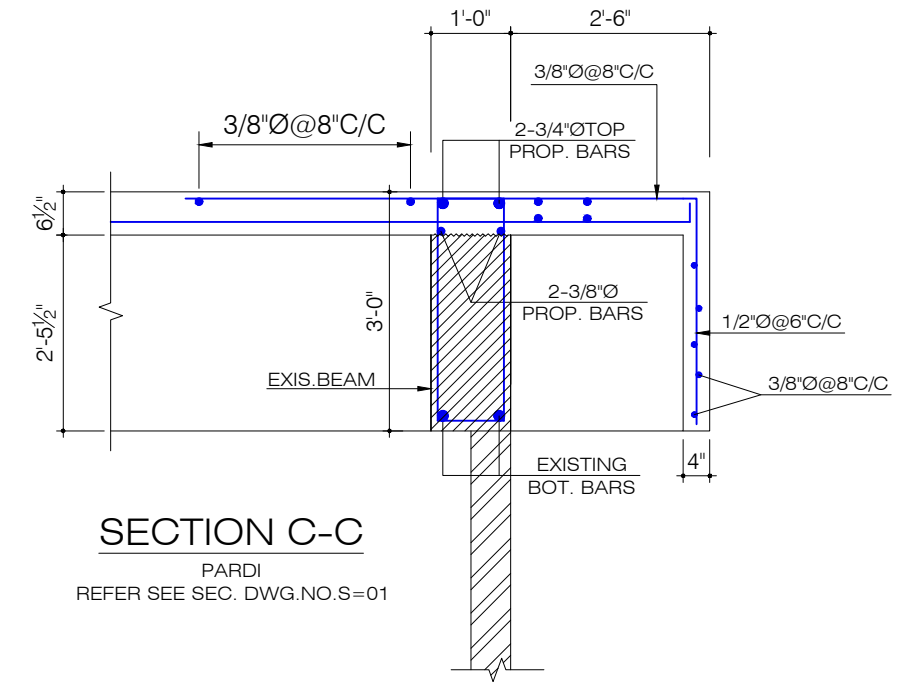

SECTION C-C
PARDI
REFER SEE SEC. DWG.NO.S=01

Client	Job	 ESS-I-AAR PLANNING, ENGINEERING & SERVICES CONSULTANTS Suite No. 314, 3rd Floor, Mashriq Centre, Sir Shah Sulaiman Road, Gulshan-e-Iqbal, Block 14, Karachi. P.O. Box 7608 Ph. 4852589 Fax (92-21)4941059	TITLE: REHABILITATION DETAILS	DATE: 09-10-24	COM. LOCATION.
MARINE ACADEMY	EXAMINATION HALL		Ref. Rev.	DRAWN: M.A	SHEET REF. STR.

NOTE :-

- 1---- OPEN CRACKS
- 2---- WIRE BRUSH AND REMOVE SCALES ON REBARS
- 3---- APPLY ZINC RICH PRIMER ON BRUSHED REBARS
- 4---- ADD 4" CONCRETE ON BOTH SIDE OF PLINT AS AS DETAILED IN DETAIL (A) PART PLAN
- 5---- CONCRETE WITH 5000 PSI CONCRETE

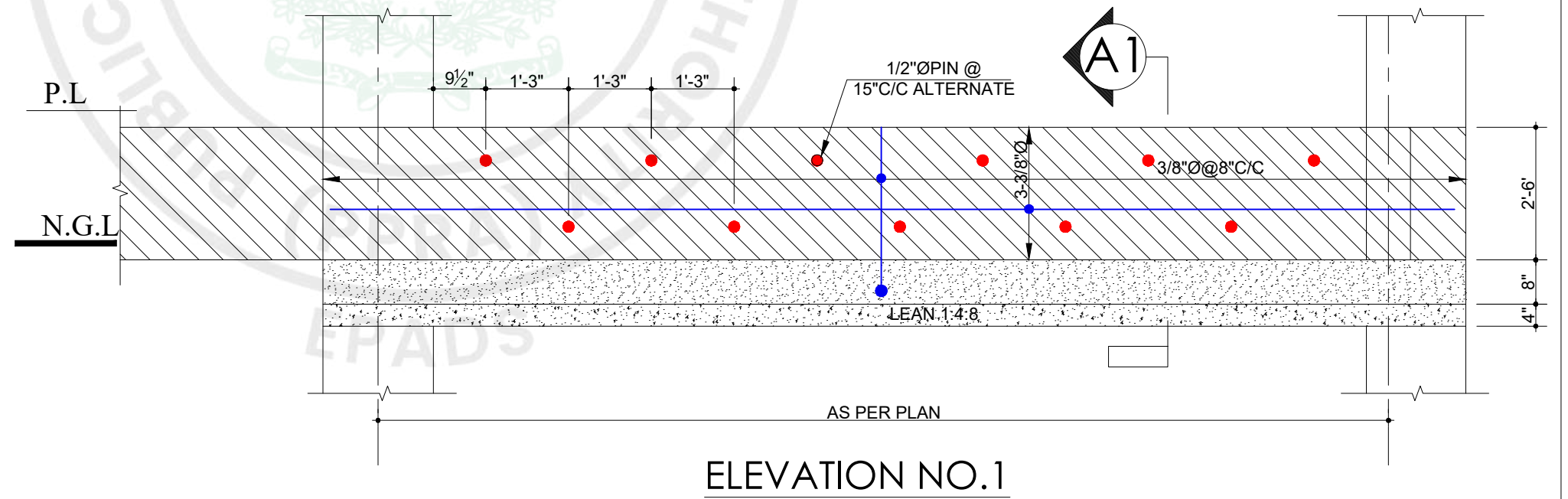
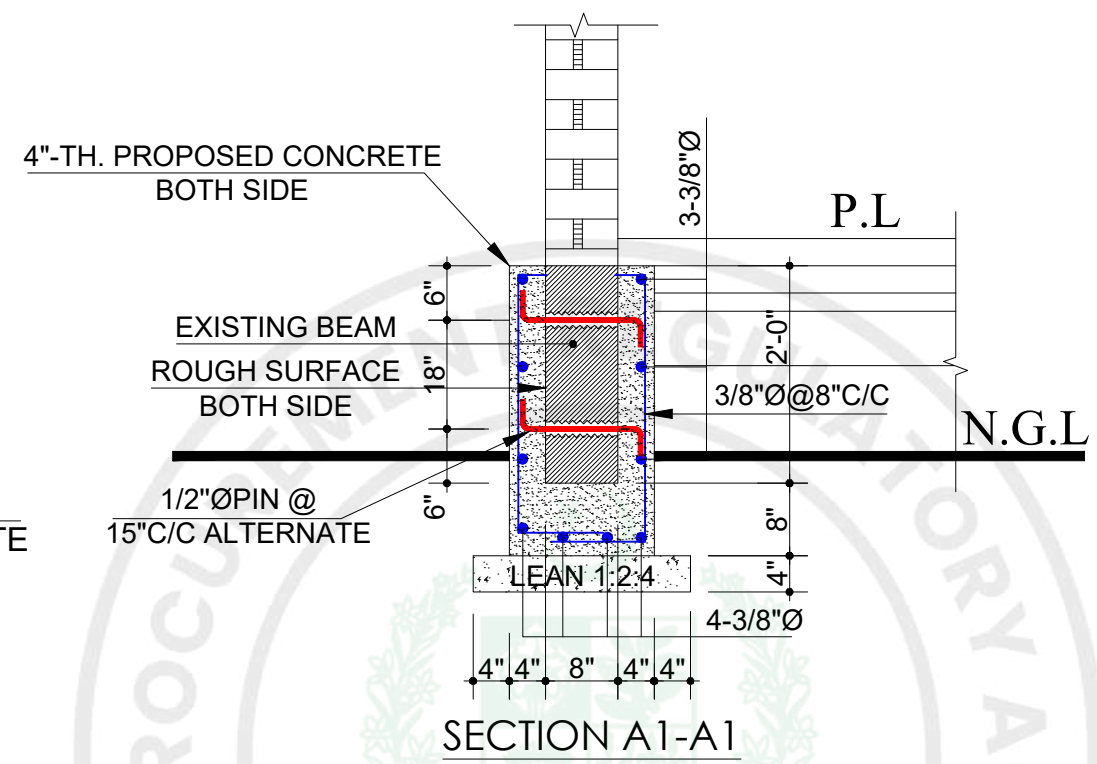
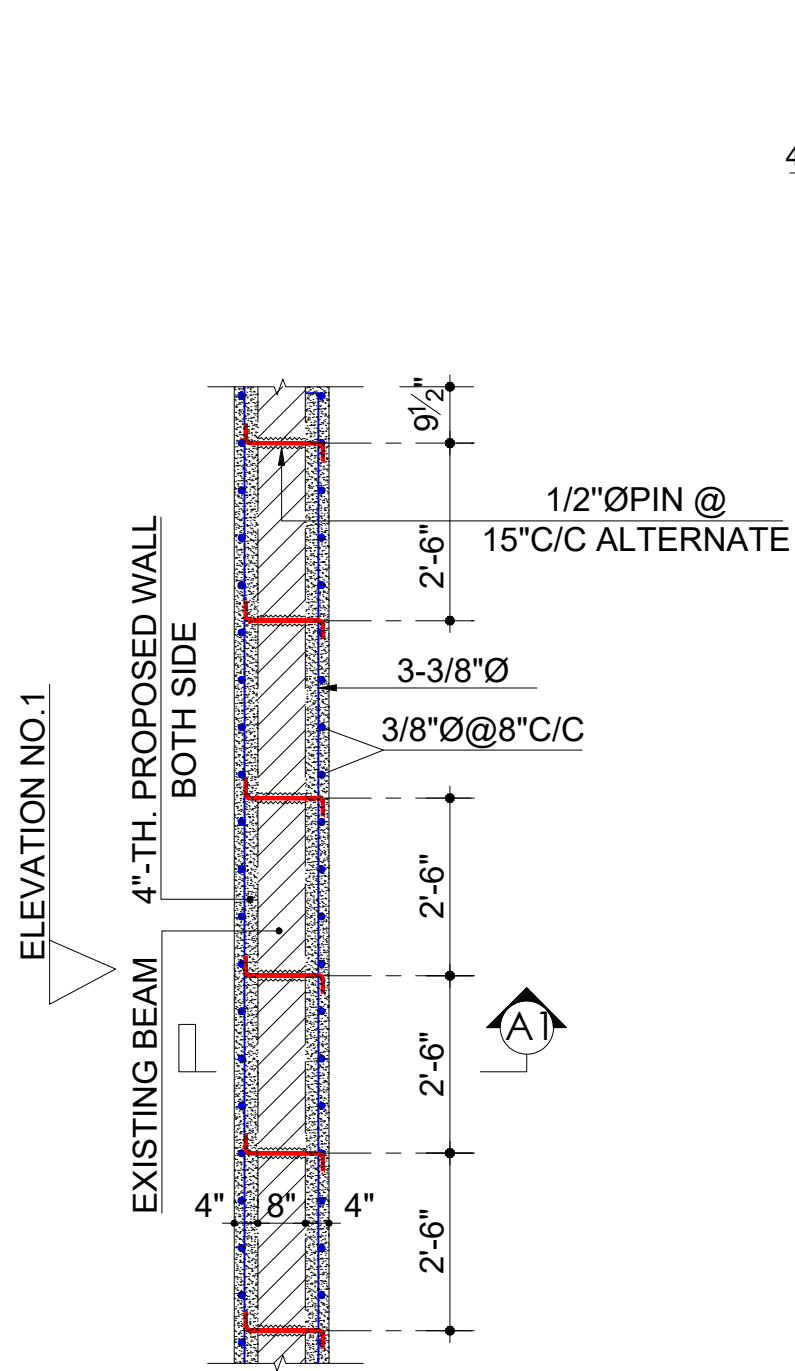

TYP. PART PLAN OF PLINTH BEAM REHABILITATION PORTION (DETAIL D)

Client	Job	 ESS-I-AAR PLANNING, ENGINEERING & SERVICES CONSULTANTS Suite No. 314, 3rd Floor, Mashriq Centre, Sir Shah Sulaiman Road, Gulshan-e-Iqbal, Block 14, Karachi. P.O. Box 7608 Ph. 4852589 Fax (92-21)4941059	TITLE:	DATE:	COM. LOCATION:
MARINE ACADEMY	EXAMINATION HALL		REHABILITATION DETAILS	09-10-24	
			Ref. Rev.	DRAWN:	SHEET REF.
				M.A	STR. S=06

CLIENT

MARINE ACADEMY

PROJECT

ADMIN BLOCK
(AS BUILT DRAWINGS)

PREPARED BY

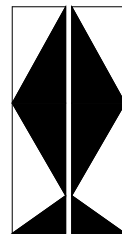

ESS - I - AAR
PLANNING, ENGINEERING & SERVICES CONSULTANTS
SUITE NO. 314 , 3 - RD . FLOOR MASHRIQ CENTRE
SIR SHAH SULAIMAN ROAD , GULSHAN - E - IQBAL
BLOCK NO. 14 , KARACHI , P. O. BOX NO. 7608
PHONE NO. 4852589 FAX NO. (92 - 21) 4941059

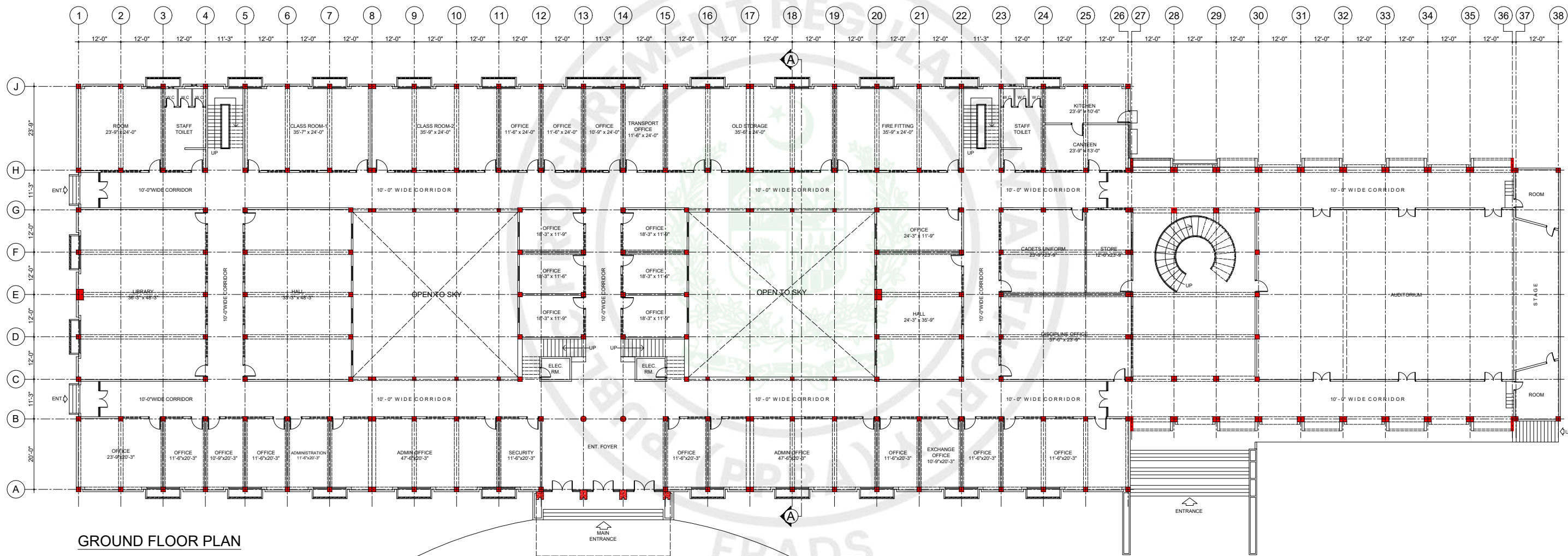

GROUND FLOOR PLAN

Client	MARINE ACADEMY	Job	QUAID BLOCK	 ESS-I-AAR PLANNING, ENGINEERING & SERVICES CONSULTANTS Suite No. 314, 3rd Floor, Mashriq Centre, Sir Shah Sulaiman Road, Gulshan-e-Iqbal, Block 14, Karachi. P.O. Box 7608 Ph. 4852589 Fax (92-21)4941059	TITLE:	DATE:	COM. LOCATION:
					Ground Floor Plan		
					Ref. Rev.	DRAWN:	SHEET REF.
						M.A	ARCH A=01

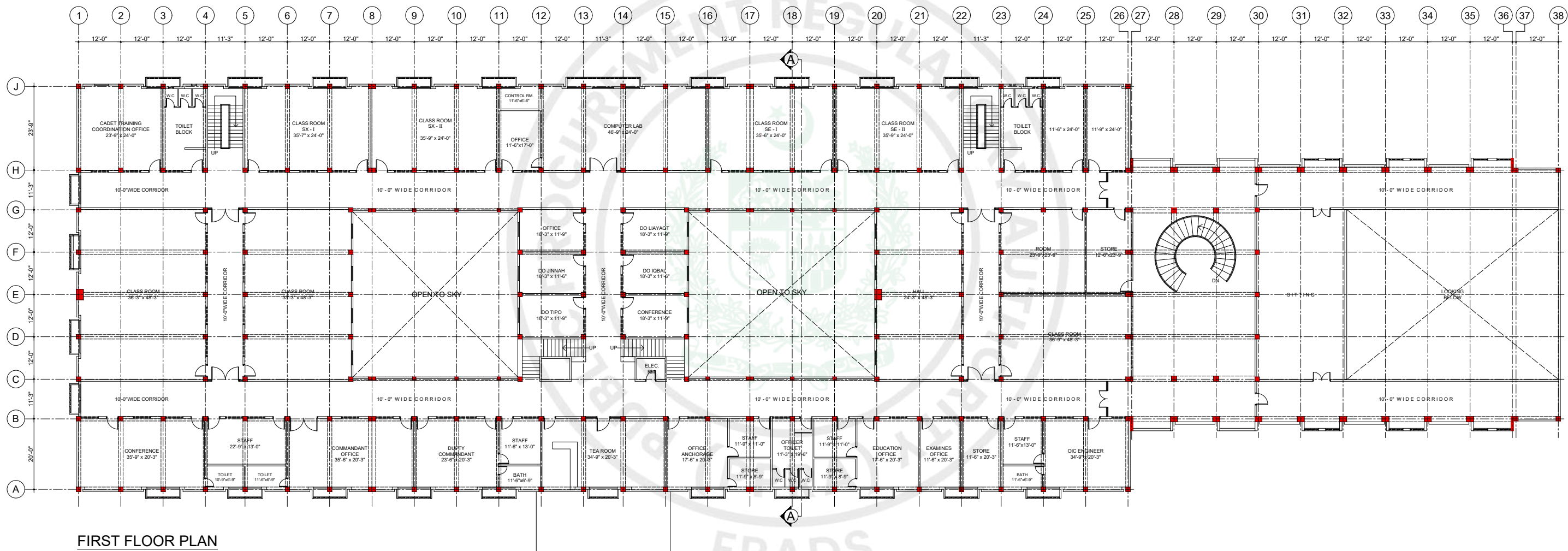

FIRST FLOOR PLAN

Client	MARINE ACADEMY	Job	QUAID BLOCK	 ESS-I-AAR PLANNING, ENGINEERING & SERVICES CONSULTANTS Suite No. 314, 3rd Floor, Mashriq Centre, Sir Shah Sulaiman Road, Gulshan-e-Iqbal, Block 14, Karachi. P.O. Box 7608 Ph. 4852589 Fax (92-21)4941059	TITLE:	DATE:	COM. LOCATION:
					First Floor Plan		
Ref. Rev.		DRAWN:	SHEET REF.				
		M.A	ARCH	A=02			

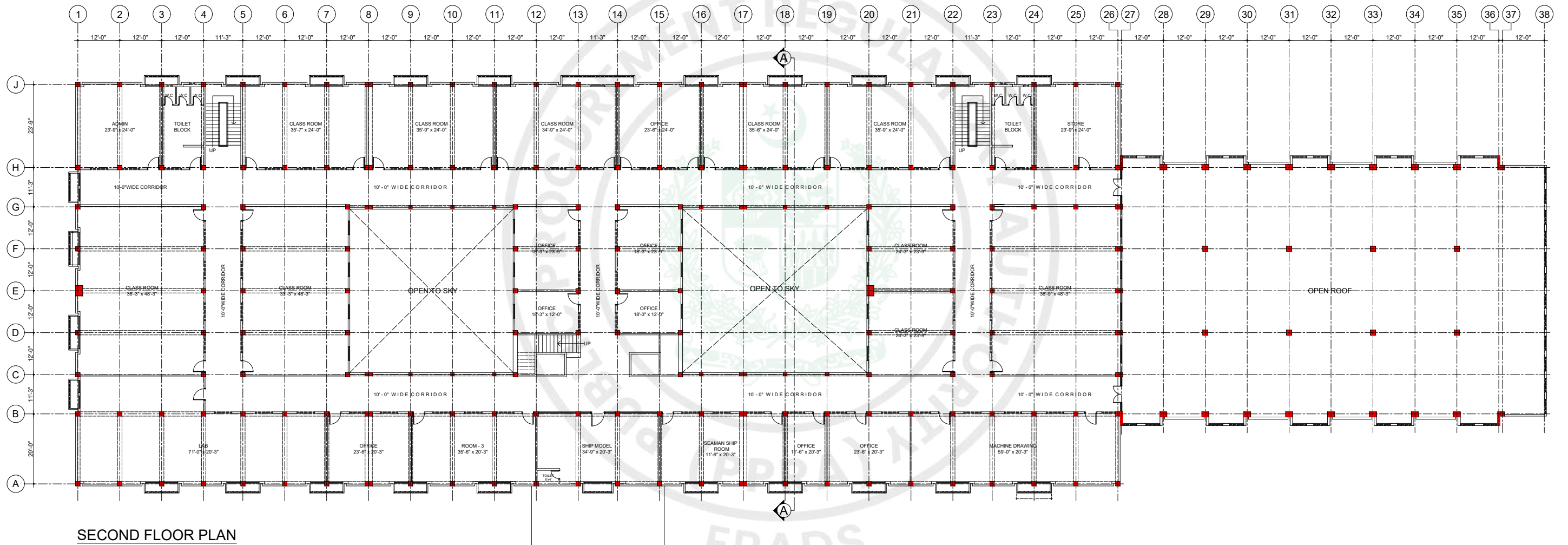
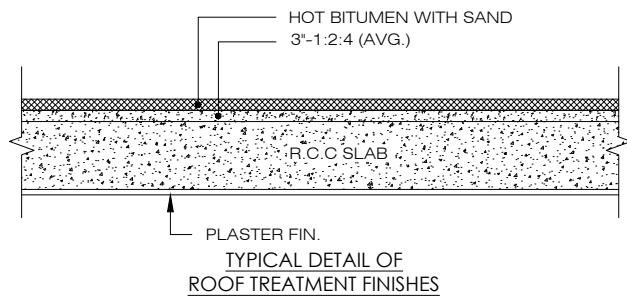

Client	MARINE ACADEMY	Job	QUAID BLOCK	 ESS-I-AAR PLANNING, ENGINEERING & SERVICES CONSULTANTS Suite No. 314, 3rd Floor, Mashriq Centre, Sir Shah Sulaiman Road, Gulshan-e-Iqbal, Block 14, Karachi. P.O. Box 7608 Ph. 4852589 Fax (92-21)4941059	TITLE:	DATE:	COM. LOCATION:
					Second Floor Plan		
					Ref. Rev.	DRAWN:	SHEET REF.
						M.A	ARCH A=03

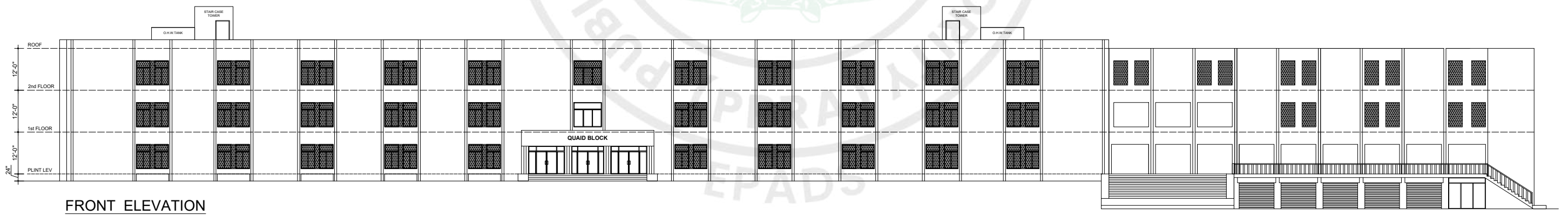
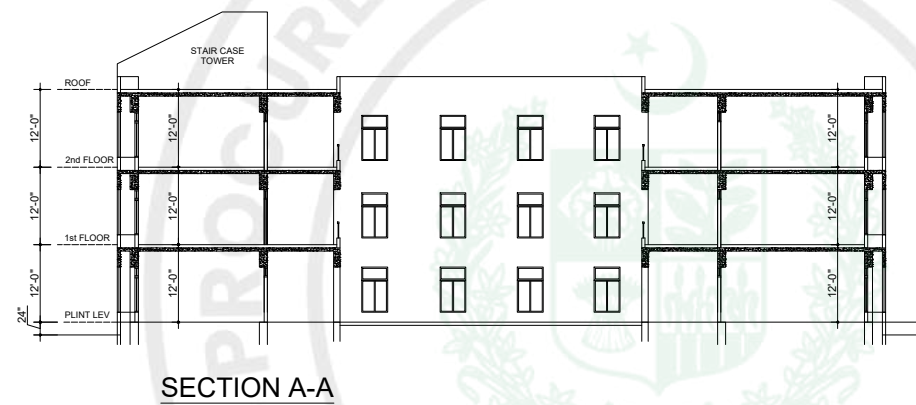

Client <p style="text-align: center;">MARINE ACADEMY</p>	Job <p style="text-align: center;">QUAID BLOCK</p>	 <p>ESS-I-AAR PLANNING, ENGINEERING & SERVICES CONSULTANTS Suite No. 314, 3rd Floor, Mashriq Centre, Sir Shah Sulaiman Road, Gulshan-e-Iqbal, Block 14, Karachi. P.O. Box 7608 Ph. 4852589 Fax (92-21)4941059</p>	TITLE: <p style="text-align: center;">Section & Elevation</p>	DATE: <table border="1" style="width: 100%; height: 20px;"> <tr> <td> </td> <td> </td> <td> </td> <td> </td> <td> </td> <td> </td> </tr> </table>							COM. LOCATION.
			Ref. Rev.	DRAWN: M.A	SHEET REF. ARCH A=04						

CLIENT

MARINE ACADEMY

PROJECT

MEDICAL CENTER

(AS BUILT DRAWINGS)

PREPARED BY

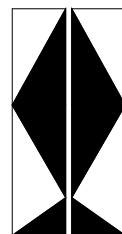

ESS - I - AAR
PLANNING, ENGINEERING & SERVICES CONSULTANTS
SUITE NO. 314 , 3 - RD . FLOOR MASHRIQ CENTRE
SIR SHAH SULAIMAN ROAD , GULSHAN - E - IQBAL
BLOCK NO. 14 , KARACHI , P. O. BOX NO. 7608
PHONE NO. 4852589 FAX NO. (92 - 21) 4941059

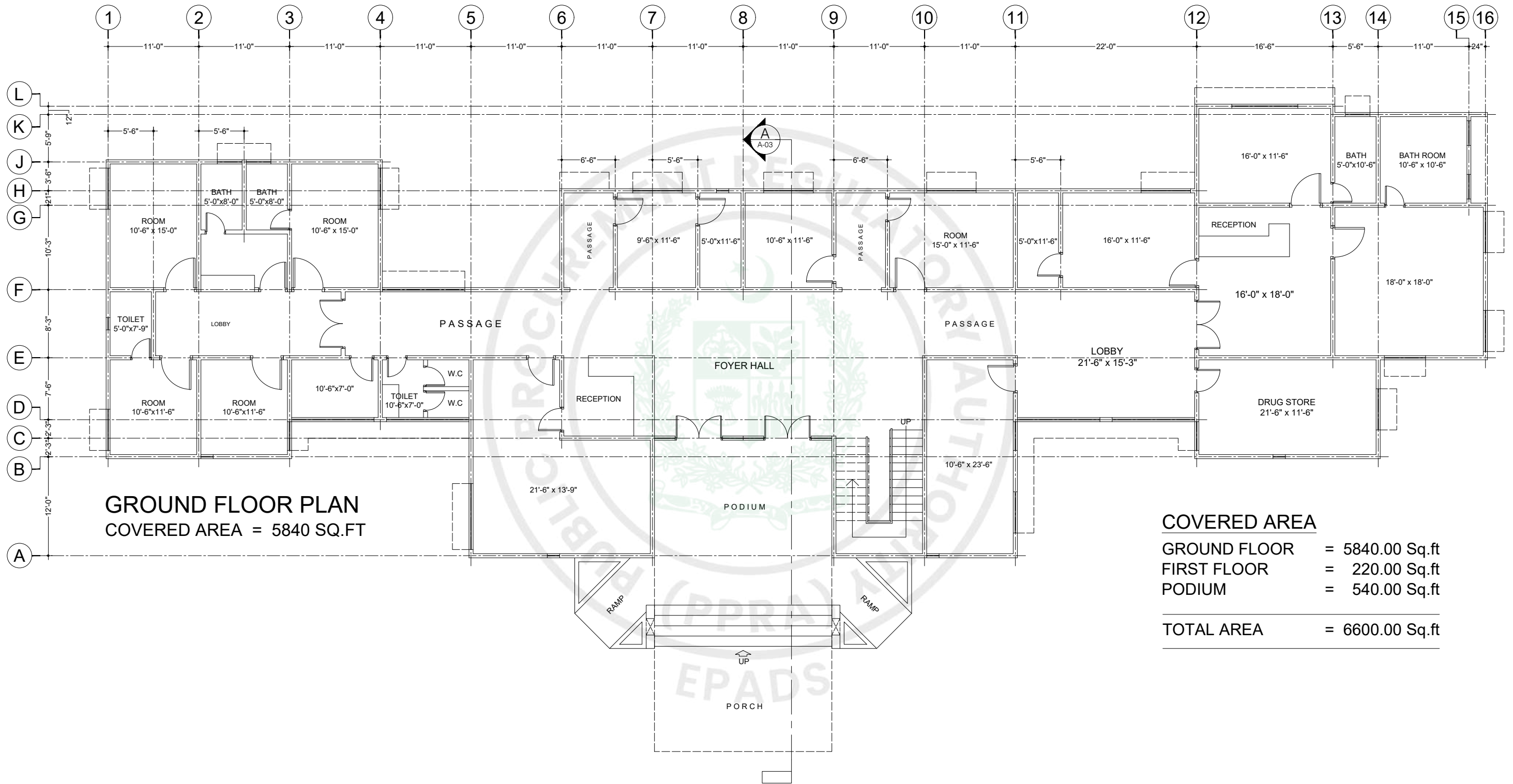

GROUND FLOOR PLAN
COVERED AREA = 5840 SQ.FT

COVERED AREA	
GROUND FLOOR	= 5840.00 Sq.ft
FIRST FLOOR	= 220.00 Sq.ft
PODIUM	= 540.00 Sq.ft
TOTAL AREA	= 6600.00 Sq.ft

Client MARINE ACADEMY	Job MEDICAL CENTER	 ESS-I-AAR PLANNING, ENGINEERING & SERVICES CONSULTANTS Suite No. 314, 3rd Floor, Mashriq Centre, Sir Shah Sulaiman Road, Gulshan-e-Iqbal, Block 14, Karachi. P.O. Box 7608 Ph. 4852589 Fax (92-21)4941059	TITLE: Ground Floor Plan	DATE:	COM. LOCATION:
			Ref. Rev.	DRAWN: M.A	SHEET REF. ARCH A=01

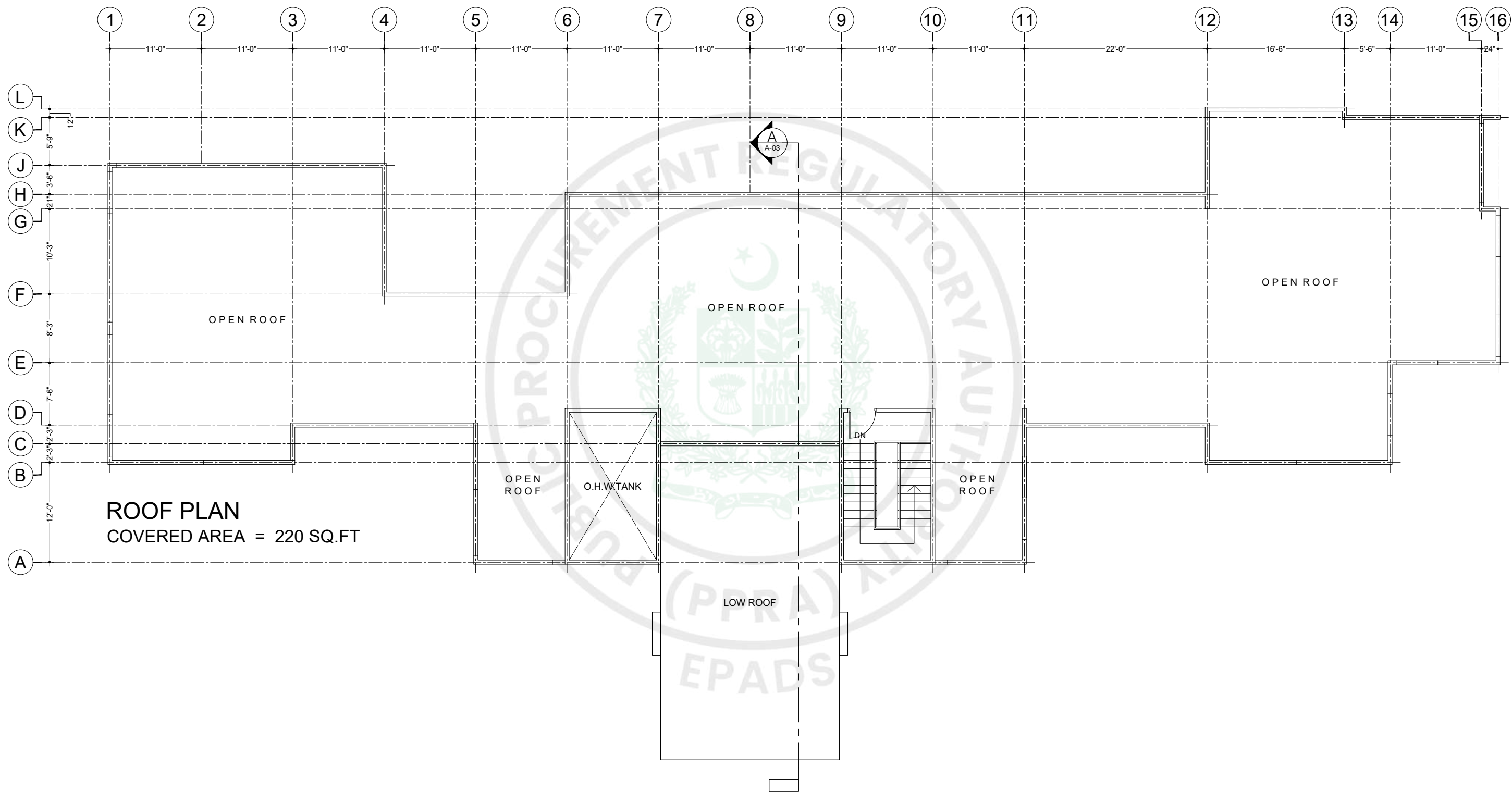

Client <p style="text-align: center;">MARINE ACADEMY</p>	Job <p style="text-align: center;">MEDICAL CENTER</p>	 <p>ESS-I-AAR PLANNING, ENGINEERING & SERVICES CONSULTANTS Suite No. 314, 3rd Floor, Mashriq Centre, Sir Shah Sulaiman Road, Gulshan-e-Iqbal, Block 14, Karachi. P.O. Box 7608 Ph. 4852589 Fax (92-21)4941059</p>	TITLE: <p style="text-align: center;">Roof Plan</p>	DATE: <table border="1"> <tr><td> </td><td> </td><td> </td><td> </td><td> </td><td> </td></tr> </table>							COM. LOCATION: SHEET REF. <p style="text-align: center;">ARCH A=02</p>
Ref. Rev.		DRAWN: <p style="text-align: center;">M.A</p>									

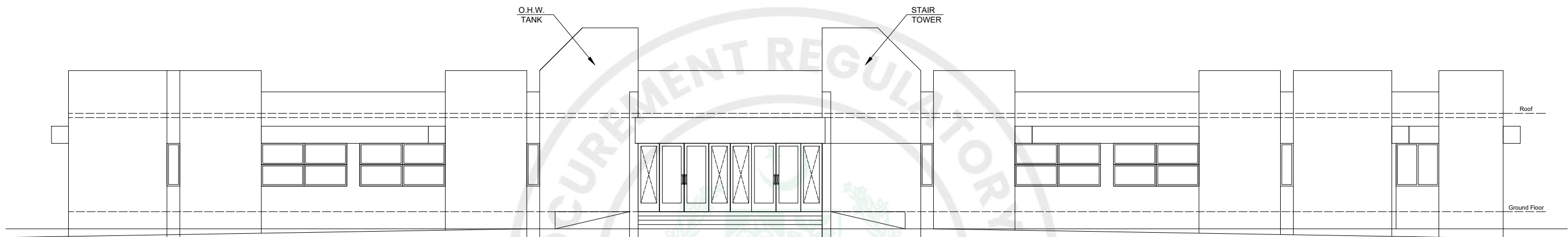

FRONT ELEVATION

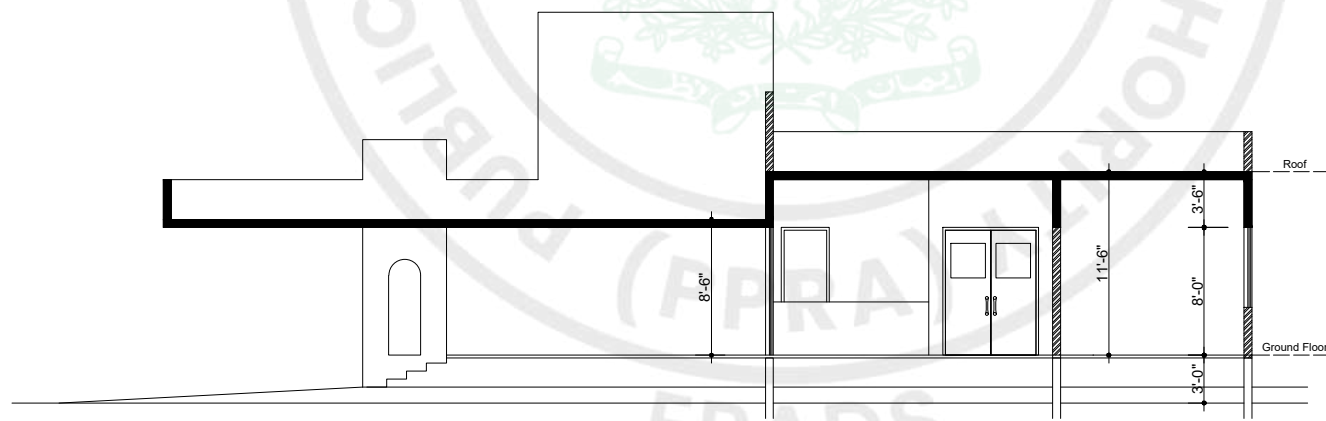

SECTION A-A

Client	MARINE ACADEMY	Job	MEDICAL CENTER	 ESS-I-AAR PLANNING, ENGINEERING & SERVICES CONSULTANTS Suite No. 314, 3rd Floor, Mashriq Centre, Sir Shah Sulaiman Road, Gulshan-e-Iqbal, Block 14, Karachi. P.O. Box 7608 Ph. 4852589 Fax (92-21)4941059	TITLE:	DATE:	COM. LOCATION:
					Section & Elevation		
					Ref. Rev.	DRAWN:	SHEET REF.
						M.A	ARCH A=03

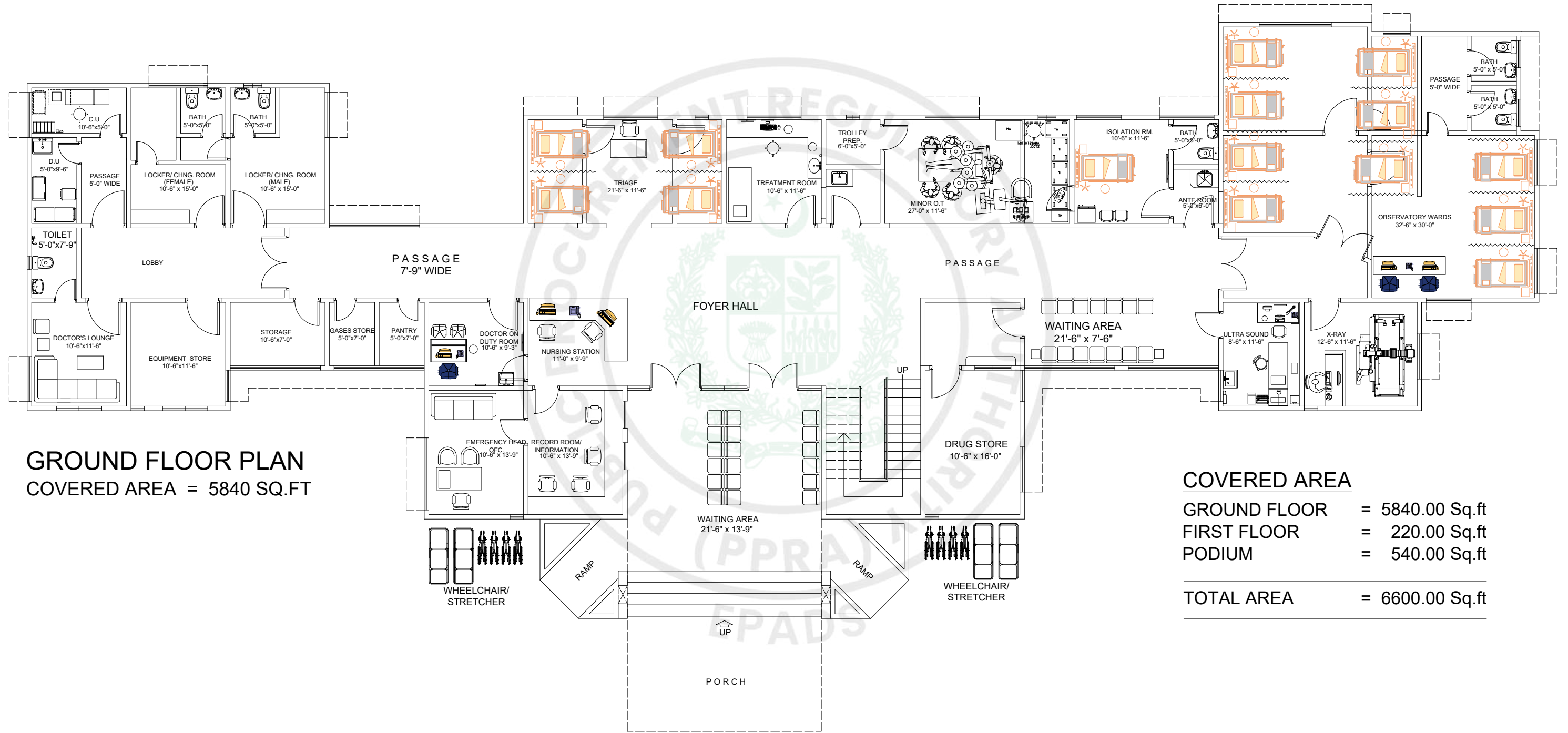

Client

MARINE ACADEMY

Job

MEDICAL CENTER



ESS-I-AAR
PLANNING, ENGINEERING & SERVICES CONSULTANTS
Suite No. 314, 3rd Floor, Mashriq Centre,
Sir Shah Sulaiman Road, Gulshan-e-Iqbal,
Block 14, Karachi.
P.O. Box 7608 Ph. 4852589 Fax (92-21)4941059

TITLE:

Ground Floor Plan

Ref. Rev.

DATE:

DRAWN:

M.A

COM. LOCATION:

SHEET REF.

FUR F-01

CLIENT

MARINE ACADEMY

PROJECT

PARADE GROUND

(AS BUILT DRAWINGS)

PREPARED BY

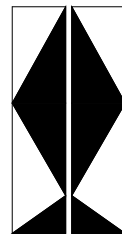

ESS - I - AAR
PLANNING, ENGINEERING & SERVICES CONSULTANTS
SUITE NO. 314 , 3 - RD . FLOOR MASHRIQ CENTRE
SIR SHAH SULAIMAN ROAD , GULSHAN - E - IQBAL
BLOCK NO. 14 , KARACHI , P. O. BOX NO. 7608
PHONE NO. 4852589 FAX NO. (92 - 21) 4941059

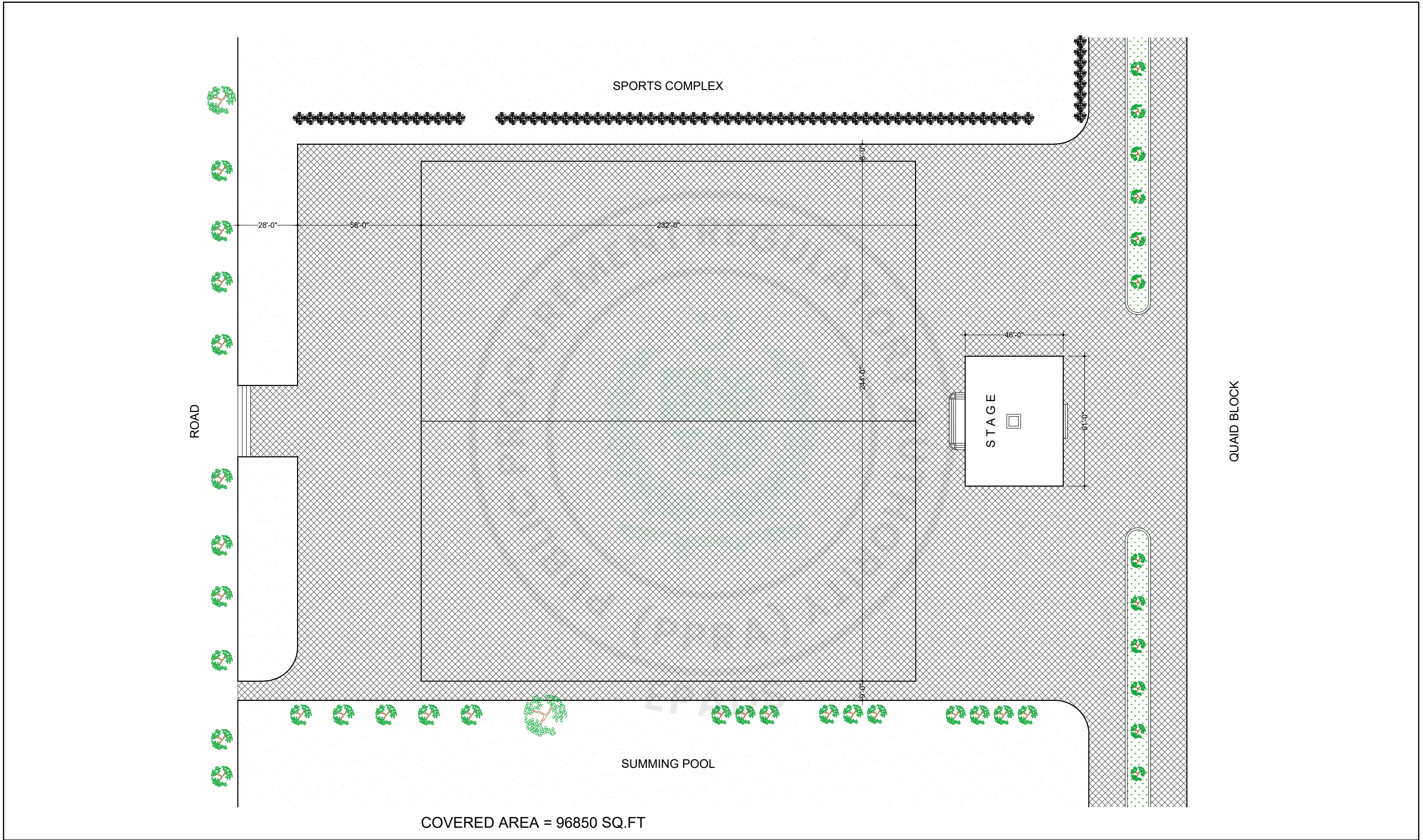

COVERED AREA = 96850 SQ.FT

Client MARINE ACADEMY	Job PARADE GROUND	 ESS-I-AAR PLANNING, ENGINEERING & SERVICES CONSULTANTS Suite No. 314, 3rd Floor, Mashriq Centre, Sir Shah Sulaiman Road, Gulshan-e-Iqbal, Block 14, Karachi. P.O. Box 7608 Ph. 4852589 Fax (92-21)4941059	TITLE: Parade Ground	DATE: _____	COM. LOCATION: _____
			Ref. Rev.	DRAWN: _____	SHEET REF. ARCH A=01

CLIENT

MARINE ACADEMY

PROJECT

SPORTS COMPLEX

(AS BUILT DRAWINGS)

PREPARED BY

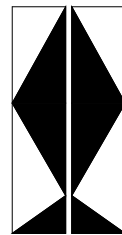

ESS - I - AAR
PLANNING, ENGINEERING & SERVICES CONSULTANTS
SUITE NO. 314 , 3 - RD . FLOOR MASHRIQ CENTRE
SIR SHAH SULAIMAN ROAD , GULSHAN - E - IQBAL
BLOCK NO. 14 , KARACHI , P. O. BOX NO. 7608
PHONE NO. 4852589 FAX NO. (92 - 21) 4941059

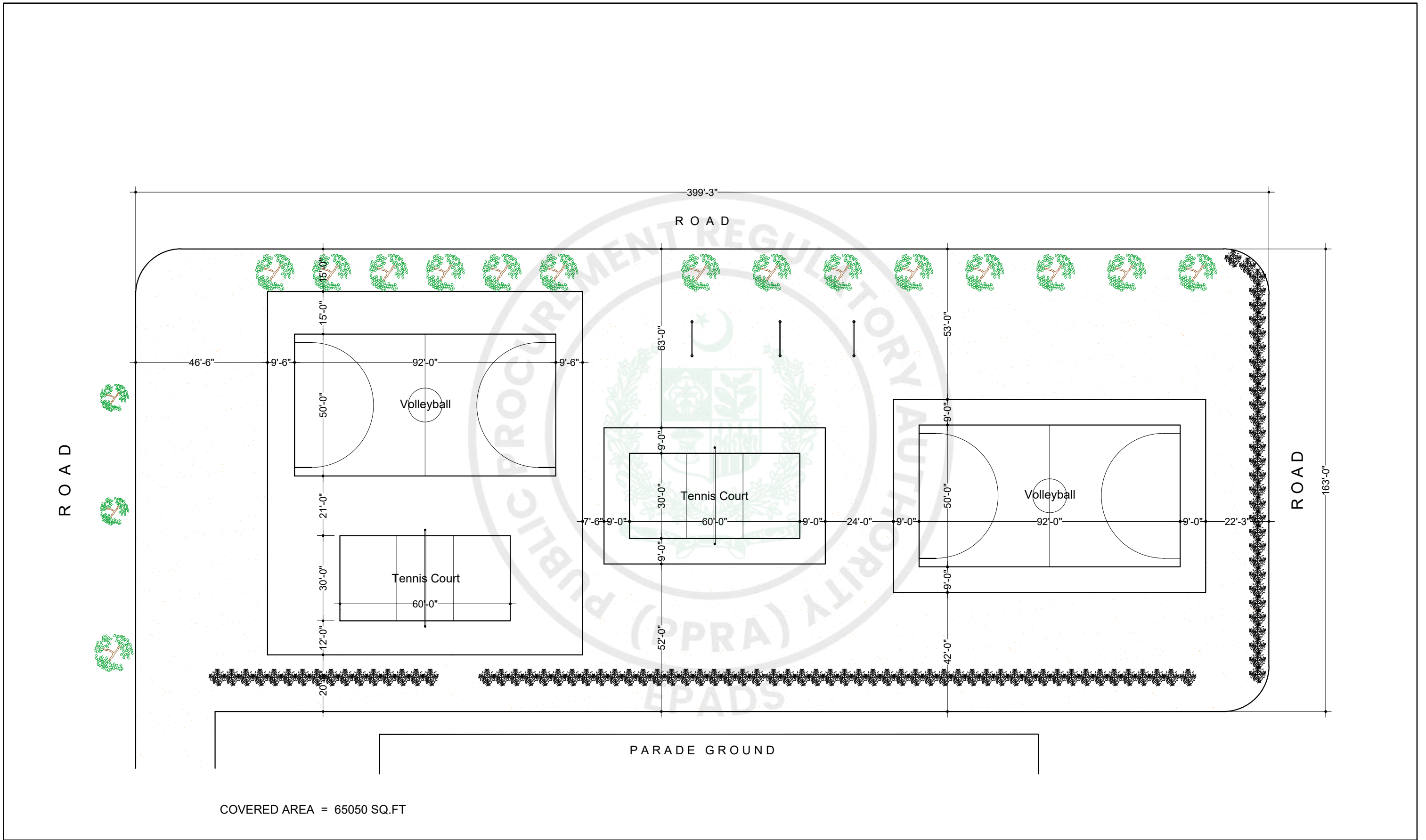

Client
MARINE ACADEMY

Job
SPORTS COMPLEX

ESS-I-AAR
 PLANNING, ENGINEERING & SERVICES CONSULTANTS
 Suite No. 314, 3rd Floor, Mashriq Centre,
 Sir Shah Sulaiman Road, Gulshan-e-Iqbal,
 Block 14, Karachi.
 P.O. Box 7608 Ph. 4852589 Fax (92-21)4941059

TITLE: Sports Complex	DATE:	COM. LOCATION:
Ref. Rev.	DRAWN:	SHEET REF. ARCH A=01

TECHNICAL SPECIFICATIONS

Table of Contents

CIVIL WORKS

1. Section-1 General
2. Section-2 Site Clearing, Grubbing and Setting out of Works
3. Section-3 Excavation, Filling, Backfill and Disposal
4. Section-4 Termite Control
5. Section-5 Water
6. Section-6 Concrete
7. Section-7 Steel Reinforcement

ARCHITECTURAL AND FINISHES WORKS

8. Section-8 Block Masonry
9. Section-9 Plastering
10. Section-10 Flooring
11. Section-11 Wooden Doors and Windows
12. Section-12 Timber Joinery and Hardware
13. Section-13 Aluminum Anodized Doors/Windows and Ventilators
14. Section-14 False Ceiling
15. Section-15 Glass & Glazing
16. Section-16 Roof Treatment
17. Section-17 Painting / Distempering
18. Section-18 Color Creting
19. Section-19 Steel Windows, Ventilators, Gates and Grills
20. Section-20 Structural Steel Works

ELECTRICAL WORKS

PLUMBING WORKS

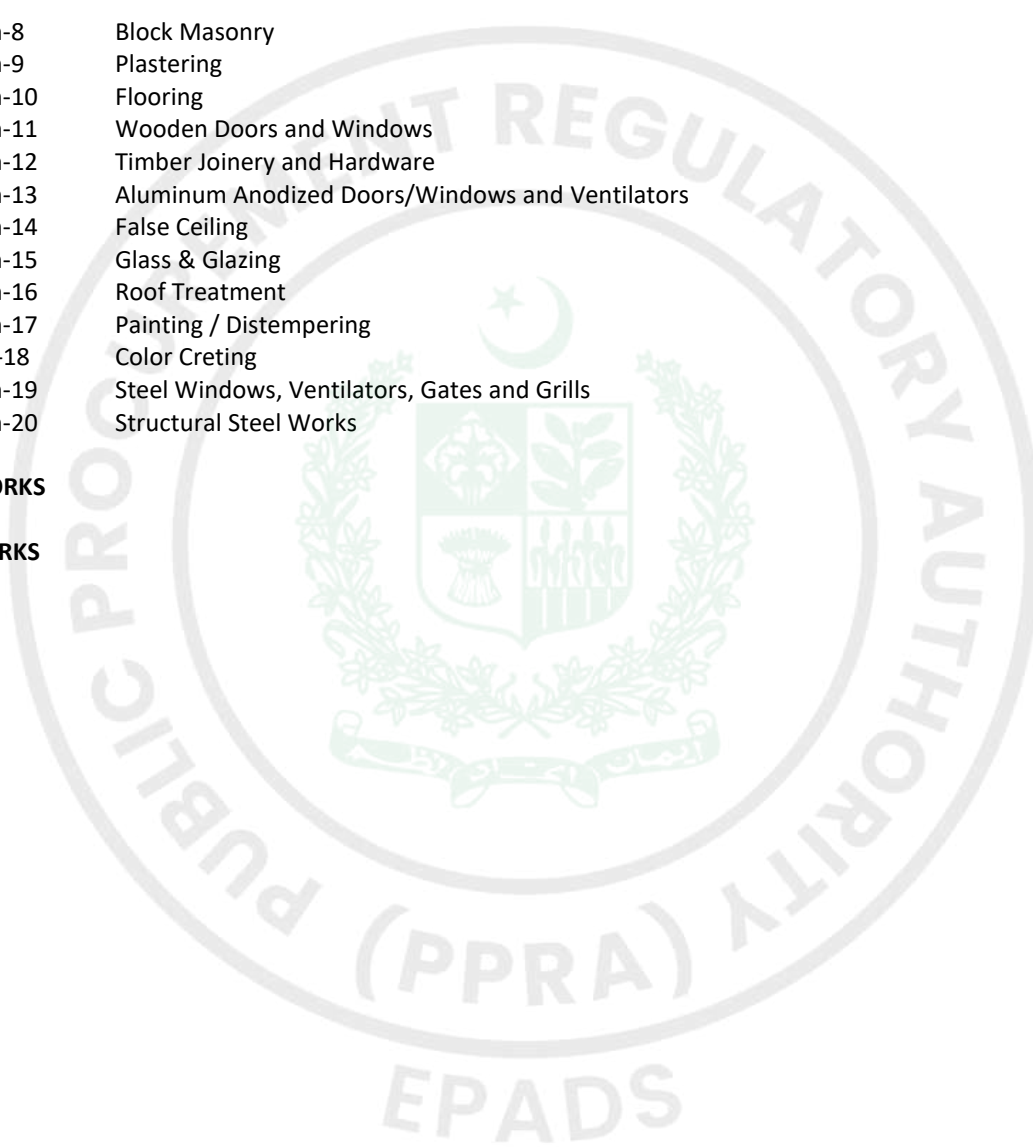

CIVIL WORKS
SECTION - 1

1.0 GENERAL

- 1.01 This General Specification is to be taken as applying to all the works in this Contract. Figured dimensions on the working drawings shall be followed in preference to the scale.
- 1.02 Until and unless specified otherwise, all goods and materials are to be Pakistan manufactured and to be of the best quality, and where not otherwise specified shall be according to latest engineering practice and conforming to Pakistan Standards (P.S) or British Standard Specifications (B.S.S) or Standard of American Society of Testing Materials (ASTM). The Engineer or the Consultants may also supplement such specifications during the progress of work.
- 1.03 All materials and goods used for such and other items shall be subjected to standard testing and if found below the specified standard such as PS or BSS or ASTM or their equivalent shall be removed from the site immediately at Contractor's own expense. All testing of materials finished and unfinished, shall be carried out by the Contractor at his cost, in the presence of Engineer or Engineer's Representative for which the Contractor shall maintain a reasonably well equipped laboratory of his own, close to the site of work or make any other additional arrangement to the satisfaction and convenience of the Engineer. The Contractor shall include testing charges in his quotations and shall not be entitled to any reimbursement on this account for routine testing.
- 1.04 The Contractor must give early attention to the submission of samples of materials for approval of the Engineer, indicating the names of the manufacturing firms, where applicable especially of cement, sand, aggregates, steel, water, tiles, hard-core and all fittings. Whenever practicable, samples shall be submitted at least three weeks before it is proposed to use the materials. Until and unless specified otherwise and whenever materials are ordered to be forwarded to a testing laboratory other than site laboratory for check/ testing, the Contractor will be reimbursed the cost of fees for such tests if proved satisfactory, by the Employer. The Contractor, however, will be required to bear the cost of the fees for tests, which proved unsatisfactory.
- 1.05 The Contractor must take all steps necessary to prevent damage or interference with all supply lines such as water, electric power, fuel, telephones, drains, buried cables and any construction designed for the use of the public, government or semi government authorities or the Employer. The Contractor shall be responsible for any damage caused to such services or constructions and settle all claims in respect of such damage.
- 1.06 The Contractor shall protect from injury by covering all work, internally and externally needing protection including new concrete, brickwork, surface renderings, floors, etc., to the satisfaction of the Engineer, including the work of his sub-contractors at his own cost.
- 1.07 The whole work shall be carried out in the best manner in accordance with the instructions contained in these documents and those given by the Engineer from time to time during the progress of the work. The work shall be carried out in conformity with the best of the standard construction practices preferably the British Codes of Practices.
- 1.08 The Contractor shall submit to the Engineer for his approval before beginning the work, a complete plan of the proposed sequence and methods of operations for the execution of the works. Detailed drawings showing the location and construction of dumping and working platforms, gantries, building and all other structures in connection with the Contractor's plant and material storage sheds shall also be submitted to the Engineer for his approval before construction.
- 1.09 Orders and directions may be given orally by the Engineer or his Representative, and shall be received and promptly obeyed by the Contractor or his Representative or any superintendent or foreman or any supervisor of the Contractor whosoever may have charge of the particular part or section of work in relation to which the orders or directions are given, and a confirmation in writing of such order or directions will be given to the Contractor by the Engineer, if so requested. The Contractor shall provide and maintain at his own expense during the performance of the work an office in the vicinity of work. Orders or directions, written or oral, from the Engineer or his Representative delivered at such office shall be considered as delivered to the Contractor. The Contractor's office shall be fitted with a telephone connected to the local Telephone Exchange.
- 1.10 The Contractor shall not use the site for any other purpose than that of carrying out this Contract work. The operations of the Contractor shall be confined to the area immediately adjoining the buildings and the works included in this Contract but site clearance shall be kept to the satisfaction of the Engineer to permit carrying out of other works by other Contractors. The Contractor shall not affix advertisements; neither shall he permit advertisements to be displayed without the written consent of the Engineer.
- 1.11 The contract drawings are the working drawings to guide the Contractor generally about the shape and size of all the structures and fittings. Before proceeding to make preparations, fabrication, execution, erection of any such fittings and other details of any temporary works, scaffolds, railings, shutterings, details of doors, windows, partitions, iron mongery works, etc; the Contractor shall be under obligation to prepare and submit all detailed shop drawings to the satisfaction and the approval of the Engineer, before doing any or all of that described above or as directed. Approval of the contractors' drawings shall not relieve the Contractor for any part of his obligation to meet all the requirements of the specifications or correctness of his drawings.
- 1.12 No cement work shall be permitted during extreme cold weather when unless otherwise authorized by the engineer.
- 1.13 No payment for extra lead and lift will be made.
- 1.14 The rates being quoted by the Contractor shall include Dewatering if required.
- 1.15 Not with-standing any item of BOQ, No LEAD or LIFT for supply of any material/ disposal of any item/ execution of any work would be given to the Contractor. The Contractor is supposed to investigate the source of all material and ascertain their cost of cartage (including all incidental costs) which would be considered incorporated in the item rates.

- 1.16 Sea sand shall be used only for bedding and backfilling under PE Pipe and will not be allowed in any other activity.
- 1.17 Any item (i) described in BOQ or relevant specifications but not shown on the Drawings, or (ii) shown on the Drawings but not described in the BOQ or relevant specifications, shall be of like effect as it has been shown and mentioned in both. Similarly, if any item which is neither shown on the drawing not mentioned in the BOQ or specification but is a pre-condition to carry out any item of the contract, it shall be considered to be included in the contract price., distributed among the rates and prices entered for the related items of works. The decision of the consultant shall be final and binding on the contractor, unless before the deadline for submission of Bids, such discrepancies are clarified by the Design consultant/ Employer. The clarification in either case would be sent to all bidder as an Addendum. However, it shall be clearly understood that no extra cost whatsoever shall be paid in case such discrepancies if any, exists in the Bid documents.
- 1.18 All diameters of pipes and fittings (MS, uPVC, RCC, FC, etc.) as mentioned in BOQs shall be minimum clear inner diameters.
- 1.19 In case PE Pipe the diameter given in the BOQ shall refer to outer diameter.
- 1.20 Notwithstanding anything contained in the Contract Documents, Employer/ Consultant reserves the right to ask for justification/ rate analysis from the contractor of any rate which in the opinion of the Employer/ Consultant is abnormally high or low. Furthermore, the quoted rates, once accepted will be valid only for the Quantities mentioned in the BOQ with a variation of +- 15%. For any further variation, the Employer/ Consultant reserves the rights to reduce any abnormally high rates quoted by the contractor as per Clause 522 of the contract.
- 1.21 Notwithstanding anything contained in the Contract, all structural concrete shall be through approved Batching plant/ Transit Mixers, as per approved design mix.
- 1.22 **PAYMENT**
Contractor shall not be entitled to any separate or additional payment on account of all these general requirements and any other arrangement or action Contractor has to undertake under the direction of the Engineer for a proper carrying out of the works and meeting all obligations of the Contract.

SECTION - 2

2.0 **SITE CLEARING, GRUBBING AND SETTING OUT OF WORKS**

2.01 **SCOPE OF WORK**

The work covered by this section of specifications consist of furnishing all labour, necessary equipment, services, miscellaneous and necessary items required to satisfactorily complete the clearing, grubbing and setting out of the works, as indicated on drawings, specified herein or both.

2.02 **CLEARING**

Clearing shall consist of cutting, or trimming of trees, if any, and the satisfactory disposal of tree and other vegetation designated for removal, together with the timber snags, bushes, and rubbish occurring within the area. Trees, other vegetation stumps, roots, and bushes in area to be cleared shall be cut off flush with or below the original ground surface except such individual trees, group of trees and vegetation as may be indicated on the drawing or designated by Engineer or his Representative to be left standing. Individual trees and other vegetation, to be left standing shall be thoroughly protected from damage during construction operation, by erection of barriers or by such other means as the circumstances require and as approved by the Engineer's Representative. Clearing operation shall be conducted in a manner that existing structures and installations under construction, employees and others remain safe.

2.03 **GRUBBING**

Grubbing shall consist of the removal and disposal of all stumps, roots and matted roots in the designated grubbing areas. Stumps, roots, logs and timber and other debris, shall be excavated and removed to a depth not less than 2 feet below any sub-grade level. In areas where the cut is over 3'-6" grubbing shall not be necessary.

2.04 **DISPOSAL OF DEBRIS**

Timber and other refuse to be disposed off by burning shall be burned at location, approved by the Engineer's Representative, in a manner that will avoid all hazard such as damage to existing structures, construction in progress, trees and vegetation. The contractor shall be responsible for compliance with all pertinent laws and regulations pertaining to the burning of fire. Disposal by burning shall be kept under constant attendance, and residual, until materials will not be permitted to be pushed or placed on the adjacent areas without written approval of the owner/owners. The stones and concrete shall be broken and removed from the site for receiving the structure/flooring where required. All debris shall be disposed off by the Contractor as directed by the Engineer.

2.05 **SETTING OUT OF WORKS**

The Contractor shall set out the works and shall be responsible for true and perfect setting out of the same and for correctness of the direction, levels, dimension and alignment of all parts thereof. If at any time any error in this respect shall appear during the progress of the works, the Contractor shall, at his own expense, rectify the error to the satisfaction of the Engineer. The Contractor shall construct accurate benchmarks so that the lines and levels can easily be checked by the Engineer.

2.06 **DRAINAGE DITCHES**

The Contractor shall construct and maintain such ditches, in addition to those shown on drawings or as may be ordered by the Engineer to adequately drain and areas under construction.

2.07 **PAYMENT**

No separate payment shall be made for the work covered in this section of the specification and all costs of site clearing and setting out shall be covered in the unit rates of the Contractor for other items.

SECTION - 3

3.0 EXCAVATION, FILLING, BACKFILLING AND DISPOSAL

3.01 SCOPE OF WORK

The work covered by this section of the Specifications consists of furnishing all Plant, Labour Equipment Appliances and materials and in performing all operations in connection with excavating, filling, backfilling and disposal for building construction, and other foundations complete in strict accordance with this section of the Specifications and the applicable drawings and subject to the terms and conditions of the Contract.

3.02 BORING LOG DATA

A preliminary report on Sub-Soil investigation and exploratory data of the site area is available for reference only in the office of the Engineer. The Employer or Engineer's predications, regarding character or extent of soil or other sub-surface conditions to be encountered during the work are not binding on the Contractor. The Contractor shall make his own deductions for sub-surface conditions which may affect methods or cost of constructions of the work hereunder and he shall make no claim whatsoever for damages or compensation, should he find conditions during the progress of the work, different from those indicated by the soil investigation report of Engineer.

3.03 EXCAVATION

(a) Classification

Excavation shall include the removal of all materials of every category and nature. If rock is encountered it shall be removed carefully and without excessive noise and vibration. Blasting shall not be resorted to without specific permission in writing from the Engineer.

(b) The excavation shall conform to the dimensions and elevations as indicated on the Drawings. Foundations on made up ground shall be taken down to natural bottom soil as per direction and approval of the Engineer. Excavation shall extend a sufficient distance from walls and footings to allow for placing and removal of forms installation of services and for inspection but the same shall not be paid.

(c) In the event of any excavations being carried out wider or deeper than authorized, the same shall be filled in by the Contractor at his own cost to the required levels with lean concrete if below footing or with properly compacted local river sand if beneath slabs or as directed by the Engineer.

(d) Shoring and Bracing:

The Contractor shall provide at his own cost, where required all shoring walls, supports etc. to the sides of the excavation to prevent sliding or any movement. Where necessary, excavated sides shall be sloped as directed by the Engineer.

(e) Dewatering and Drainage:

The Contractor shall control the grading in the vicinity of site of work in order to prevent any water from running into the excavated areas. He shall at his own cost keep dry all pits and trenches during construction and all de-watering and pumping out whether due to ground water seepage or otherwise, shall be included in the rates as quoted by the Contractor. The method employed in all cases shall be approved and agreed by the Engineer or his Representative.

(f) Protection of utility lines:

When any existing utility lines whether to be retained or be removed are encountered within the area of operations, the Contractor shall notify the Engineer and his Representative, and shall not proceed until necessary measures are taken for protection or removal of the lines and instructions are obtained from the Engineer.

(g) Excess and undesirable material from excavation not required for fill or backfill of the building site, shall be disposed off, removed and/or deposited as for filling and leveled anywhere on the work site as directed by the Engineer. Earth suitable and meant for backfill shall be stored at site in a manner not to interfere with the progress of construction works.

3.04 FILL AND BACKFILL

Where concrete slabs are to be placed on the ground, any loam, organic and other unsuitable material shall be removed. Fill where required to raise the sub-grade for concrete slabs shall be clean, unadulated local river sand or gravel and shall be free from wood, stones and other debris. Excavated material shall only be used for fill if approved by the Engineer in writing. All the backfill behind the sub-grade walls shall be done with clean local river sand or approved excavated soil. Fill shall be compacted upto 95% modified AASHTO Density by a Power vibratory roller, mechanical rammer, or other approved equipment, in layers not more than 6 inch thick. Each layer shall be uniformly spread, watered to the extent of optimum moisture requirement for the required degree of compaction and then compacted. Contractor shall arrange at his own cost the testing of the filling where required by the Engineer or his Representative, after completion of foundation footings, walls, slabs and other construction below the elevation of the final grades and prior to backfilling. Backfill shall be placed in horizontal layers not more than 6 inches thick and shall have proper moisture content for the required degree of compaction of 95%. Each layer shall be compacted by mechanical tampers or by other suitable equipment approved by the Engineer. Backfill shall be brought to a suitable elevation above grade to provide for anticipated settlement and shrinkage thereof.

Backfill shall not be placed against foundation walls etc., prior to the damp proofing treatment, if specified and approved by the Engineer or his Representative. Backfill shall be brought up evenly on each sidewall as far as practicable. Heavy equipment for spreading and compacting backfill shall not be operated closer to the wall than distance equal to the height of the backfill above the top of footing.

3.05 COMPACTION:

Fill and/or backfill within the building or structures and for a distance of 6 ft. outside structures shall be compacted to a density of not less than 95% maximum density at optimum moisture content.

3.06 **ROUGH GRADING:**

- (a) Necessary rough grading shall be carried out by the Contractor to establish grade or construction requirements of the site. Grades not otherwise indicated shall be uniform levels or slopes between points on existing and finished grades. Abrupt changes in slopes shall be rounded. Additional fill required to complete rough grading shall be provided as directed by the Engineer or his Representative.
- (b) Where paving or slabs are specified, all rough grading shall be done to the sub-grade of the base course, removing all large stones and debris and shall be compacted uniform to the correct lines and levels ready to receive the paving or slab. Refilling, where required shall be executed with suitable selected materials in layers not exceeding 6 inch thick and thoroughly compacted to the required density. In place density tests shall be carried out by the Contractor for the approval of the compaction by the Engineer.

3.07 **FOOTING BOTTOM LEVELS:**

The levels as noted in the Drawings are only approximate and must be adjusted in the field with the approval of Engineer, depending on the soil conditions encountered. No concreting shall begin until the soil bearing capacity is substantiated by visual inspection by the Engineer or his Representative. The Contractor in planning his work shall make arrangement and provisions to construct the lowest level footings first.

3.08 **FIELD LEVELS:**

Prior to starting the work, the Contractor shall arrange to take the levels of the piece of land on which the building is located as directed by the Engineer. The same shall be simultaneously checked by the Engineer or his Representative and shall form the basis of payments for excavation and filling etc.

3.09 **DISPOSAL OF SURPLUS EARTH AND RUBBISH:**

All surplus earth and rubbish shall be disposed off at site as directed by the Engineer. The term disposal shall include all operations of loading, unloading, stacking, spreading, re handling, filling in depressions, including consolidating and ramming in layers not exceeding 6 inch thickness.

3.10 **MEASUREMENTS AND PAYMENTS:**

All excavation shall be measured net and perpendicular and no allowance shall be made for any increase in bulk of the excavated material after excavation or for sloping sides, or widened trenches to accommodate formwork, shoring and bracing etc. Similarly the measurements for filling/backfilling shall be thoroughly compacted and measured net and no allowance shall be made for any increase in bulk after excavation. Excavation, filling and Disposal shall include all leads and lifts as specified elsewhere in these specifications. Payment for all the items under this section shall be made at the rates entered in the BOQ appended to the contract and in accordance with the applicable conditions of the contract.

Note:-

- 1. Imported earth fill item payment will be separately paid as per BOQ appended to the contract and in accordance with applicable condition of the contract.

SECTION - 4

4.0 **TERMITE CONTROL**

4.01 **SCOPE OF WORK:**

The work covered by this section of Specification consists of furnishing all labour, materials, equipment, services, miscellaneous and necessary items required to complete Termite Control work, related works as indicated on drawings specified herein or both.

4.02 **MATERIALS:**

- (a) Pesticides shall be solution of an approved chlorinated hydrocarbon such as 0.5% Dieldrin or 0.5% Aldrin mixed in clean water for application to or in earth, and mixed in pure turpentine for application to wood.
- (b) Pesticides (dieldrin and aldrin) shall be obtained from the Government of Pakistan, Department of Agriculture, in sealed drums at rates in force at the time of their acquisition and only in the quantity necessary for work of this Project. All mixing shall be done at site and the amount of pesticides used shall be verified by the Engineer his Representative.

4.03 **METHOD OF APPLICATION:**

Pesticides solution shall be applied with approved pressure spraying equipment maintaining a pressure of IN/Sq.mm (150 lb/sq.in.) for all applications, to, on, or in earth. Spraying to wood shall be done by hand compassion sprayers with an approximate pressure of 0.15 N/Sq.mm (20 lb/Sq.in).

4.04 **EXTENT OF APPLICATION:**

- (a) At excavation, all walls and bottoms of all pits or trenches for footings or foundations are to be sprayed. Pesticide shall penetrate to a depth of 1'-0" minimum in porous earth at bottom and 3" minimum at sides of excavations.
- (b) Stockpiled excavated material to be used as back fill is to be treated as above. After back-filling to plinth level, area of the whole building upto 10'-0" outside the building line is again to be sprayed penetrating a minimum of 1 ft. into soil.
- (c) After grading, compaction and sand filling before formation of hard core/soling under floor slabs all areas to be covered shall be sprayed with pesticides, penetrating a minimum of 1 ft. into soil.
- (d) All rough woodwork for the entire project shall be pesticide treated (before application of so lignum in the case of material to receive both treatments). Pesticide shall be sprayed on all surfaces of blocking, furring, planks,

scantlings, boards etc. before installations. Spraying shall be once again done at the site, after delivery and before installation. All spraying will be done within one week of working of the material.

4.05 **LOCATION AND SCHEDULING:**

- (a) Saturation of earth is to be done in such a manner as to in no way disrupt the progress of work.
- (b) Spraying of rough woodwork shall be done on or near the site at location and in such enclosures as proposed by the Contractor and approved by the Engineer. Such work is to be scheduled and done by sufficient skilled personnel as to in no way impede the progress of the work.
- (c) Care shall be exercised to ensure that no marks or damage occurs to the finished building as a result of the work under this Section, and Contractor shall verify and ensure that no material used herein will impede the growth of grass or plants at areas where spraying is done.

4.06 **STANDARD:**

All methods of termite protections used herein shall be in accordance with the standard practices of National Pest Control Association, U.S.A, and the British Wood Preserving Association.

4.07 **GUARANTEE:**

The Contractor is to guarantee that the building shall be free from termite (white ants), wood bores and other pests or rodents which cause damage to wood or other organic material for 10 years from the date of acceptance of the building.

In the event of any damage caused within the guarantee period, the Contractor shall replace at his own cost such damaged material finishes affected and suitably preserve and treat the entire premises with the best method known to the trade to prevent the spreading of termites and other pests.

4.08 **TESTING:**

All materials and samples shall be subjected to standard testing in accordance with the standards specified herein and shall be rejected if found below these standards. Rejected materials shall be removed from the site immediately.

4.09 **PAYMENT:**

Payment will be made for building site which will be paid separately on the basis of plinth area covered by this treatment including all ditches, pits, excavation, fills etc. complete as per rate quoted in the Bill of Quantities.

SECTION - 5

5.0 **WATER**

5.01 **SCOPE:**

The work covered by this section of the Specification consists of furnishing all labour, appliances and in performing all operations in connection with obtaining, conveying and storing water at site of work.

5.02 **QUALITY OF WATER:**

The water used for construction shall be free from impurities and fit for drinking purpose.

5.03 **TESTING:**

Water if required, shall be subjected to standard testing at the cost of the Contractor and if found to be unsuitable for construction work then the Contractor shall take such action as directed by the Engineer.

5.04 **PAYMENT:**

No separate payment will be made for the work covered under this section, and all costs in connection therewith shall be deemed to be included in the unit rates.

5.05 **TEMPORARY STORAGE TANK:**

The Contractor shall provide on site at his own cost temporary storage water tank with all necessary G.I. Pipes and fittings as per instructions of the Engineer. No separate payment will be made for tank, pipes and accessories, etc. These tanks shall be removed or dismantled or demolished and the area shall be cleaned and made good on completion of work as per direction of Engineer.

SECTION - 6

6.0 **CONCRETE**

6.01 **SCOPE OF WORK:**

The work covered by this section of the Specifications consists of furnishing all plants, labour equipment appliances and materials and in performing all operations in connection with concrete work complete in strict accordance with the applicable Drawings and the Specifications herein and subject to the terms and conditions of the Contract.

6.02 **GENERAL:**

Full cooperation shall be extended to other trades to install embedding items, and form ducts and openings etc. Embedded items shall have been inspected and check tested for concrete and other materials or for mechanical operations and approved before concrete is placed.

6.03 **MATERIALS:**

6.03.1 **CEMENT**

- i) Grey/ white Portland Cement shall be normal setting cement of the specific gravity, fineness and chemical composition fully conforming to Pakistan Standard Specifications P.S. No.232:1967 and shall be capable of satisfying all tests such as the tensile strength tests contained therein. Standard test briquettes prepared with 1:3 cement sand mortar shall give the following tensile strengths:

At 3 days not less than 300 Lbs/Sq.in(2.1N/Sq.mm).

At 7 days not less than 400 Lbs/Sq.in(2.8N/Sq.mm).

- ii) Sulphate Resistant Cement where required shall be sulphate Resistant Cement type 'A' fully conforming to Pakistan Standard Specification PS No.612:1967 and satisfying the requirements for fineness, chemical composition strength, setting time and soundness, etc.
- iii) For all types of cements, described in sub-Clauses (i) and (ii) above, the average compressive strength of three concrete cubes shall not be less than 1200 Lbs/Sq.in(8.2 N/Sq.mm) at three days and not less than 2000 Lbs/Sq.in(14 N/Sq.mm) at seven days as described in Ps.No.232.1962. Alternatively, the average compressive strength of three mortar cubes prepared with 1:3 cement and standard silica sand mortar shall not be less than 2200 Lbs/Sq.in(15.2 N/Sq.mm) at three days and not less than 3400 Lbs/Sq.in(23.5 N/Sq.mm) at seven days. The initial setting time shall not be less than 45 minutes and final setting time not more than 10 hours.
- iv) The supply of cement must be so programmed by the Contractor that at no time the quantity of cement stock shall be less than that required for an average consumption of four weeks. Lorry or truck or other means of transportation, for the conveyance of cement to the site of works, shall be clean, dry, metalled lined and covered from top with water proof sheets, so that cement is sufficiently protected from any deterioration during transit.
- v) The Contractor shall provide at his own cost, on the Site, all necessary sheds, which shall be perfectly dry and watertight for the storing of cement to be delivered to the works, to ensure adequate supplies being available at site of work.
- vi) If at any time the Engineer or his Representative considers that any batch of cement may have deteriorated on the site during storage for any reason, he will direct that tests shall be made and that batch of cement on the site shall not be used until it has been shown by test at a laboratory, approved or appointed by the Engineer, to be satisfactory. Contractor shall bear all costs of such testing. Any rejected cement shall be removed from the site by the Contractor without delay. Cement reclaimed from cleaning bags or leaking containers shall not be used.
- vii) Cement shall be consumed in the sequence of receipt of shipments unless otherwise directed by the Engineer or his Representative.

6.03.2 AGGREGATES

- i) All fine and coarse aggregates to be used shall be supplied from approved sources, which shall not be changed without permission in writing from the Engineer. Aggregates shall conform to the test requirements of Pakistan Standard 243:1963 or equivalent.
- ii) Fine aggregates, shall be approved sand and shall be clean, sharp, free from clay, earth, vegetable and organic matters, alkaline or acid reactions or other deleterious matter or impurities.
- iii) Fine aggregates shall conform to Pakistan Standard Specifications PS No.243:1963 "Natural Aggregates for Concrete" and shall be graded as follows: -

B.S. SIEVE NUMBER.	PERCENTAGE (BY WEIGHT) PASSING	
	Grading Zone 1	Grading Zone 2
3/8"(9.5 mm)	100	100
3/16"(4.8 mm)	90 - 100	90 - 100
No. 7	60 - 95	75 - 100
No. 14	30 - 70	55 - 90
No. 25	15 - 34	35 - 59
No. 52	5 - 20	08 - 30
No.100	0- 10	00 - 10

- iv) Coarse aggregates shall be approved hard crushed stone from a source approved by the Engineer and shall be clean, free from sand, dust, salt, lime, chalk, clay and organic impurities or other deleterious matter.
- v) Coarse aggregates shall conform to the relevant Pakistan Standard Specifications PS No.243:1963 Coarse aggregate shall be graded as follows: -

FOR CONCRETE CLASSES A, B & C (Nominal Size of Graded Aggregate 3/4" to 3/16" (19 mm to 4.8 mm).

B.S. SIEVE NUMBER	PERCENTAGE (BY WEIGHT) PASSING
1" (25.4mm)	100
3/4" (19 mm)	90 - 100
3/8" (9.5mm)	020 - 55
3/16"(4.8mm)	000 - 10

FOR CONCRETE CLASSES D & E (Nominal Size of Graded Aggregate 1-1/2" to 3/16" (38 mm to 4.8 mm).

B.S.SIEVE NUMBER	PERCENTAGE (BY WEIGHT) PASSING
1 1/2" (38 mm)	100
1" (25.4 mm)	95 - 100
3/4" (19 mm)	35 - 70
3/8" (9.5mm)	10 - 33
3/16"(4.8mm)	0 - 5

- vi) All aggregates shall be stored on properly constructed paving and in bins and there shall be a physical partition between the stockpiles of coarse and fine aggregate. No mixed-up aggregates shall be used in any concrete. Under no circumstance's aggregates shall be allowed to be in contact with ground.

- vii) If required, aggregates shall be washed and screened to the satisfaction of the Engineer or his Representative before use by processing through proper screening and washing plant. Adequate time is to be allowed therefore, for the moisture content to become substantially uniform before use in works.
- viii) Sieve analysis and other necessary tests of all aggregates shall be carried out as and when required by the Engineer or his Representative. Samples for such tests shall be taken in the presence of the Engineer or his Representative. All costs in connection with the tests shall be borne by the Contractor.
- ix) All aggregates shall be subject to the approval of the Engineer. Any batch of aggregates not found to the required standard shall be rejected by the Engineer or his Representative and shall have to be removed from site without delay. Concrete structures executed with rejected aggregates shall be dismantled and rebuilt at the Contractor's expense.
- x) Special fine gravel of 9 mm (3/8") or 12 mm (1/2") maximum size shall be used if and where called for on the Drawings or as directed by the Engineer.
- xi) If suitable gravel meeting with the Specifications is not procured by the Contractor, he will have to arrange suitable crush stone if demanded by the Engineer. No extra payment shall be made to the Contractor to effect this change.

6.03.3 WATER shall be as specified under section on water.

6.04 CLASSIFICATION OF CONCRETE:

Classes of concrete to be used in various parts of the works shall be as indicated on the drawings and mentioned in Bill of Quantities. The concrete of various grades shall be proportioned as set out in Table-I appended hereto.

TABLE-I: Showing minimum required compressive strengths 150 x 150 x 150 mm (6"x6"x6") test cubes and minimum quantity of cement required per m³ or 100 cft. of finished concrete for various mixes and under various conditions.

Class of Concrete	Nominal Min. Ratio	Min. Qty. of Cement		Preliminary Cube strength				Work Cube	
		Lbs. per 100 cft.	Kg. / Cu.m	at 7 days		at 28 days		at 7 days	
				Lbs./ Sq. in.	N/ Sq.mm	Lbs./ Sq. in.	N/ Sq.mm	Lbs./ Sq. in.	N/ Sq.mm
A.	1:1:2	3024	485	4000	28.0	4500	31.5	3000	21.0
B.	1:12:3	2520	404	3350	23.4	3750	26.3	2500	17.5
C.	1:2:4	2016	323	2700	18.9	3000	21.0	2000	14.0
D.	1:3:6	1344	216	1300	9.1	1500	10.5	1000	7.0
E.	1:4:8	1008	161	850	5.9	1000	7.0	650	4.5

6.05 PROPORTIONING OF CONCRETE MIXES:

6.05.1 All concrete shall be proportioned by volume for concrete mixes, unless specifically directed by Engineer to proportion them by weight, when the ratios will also differ. The proportions given above in Table-I are suitable only when the specific gravities of the aggregates are in the region of 2.5. The Contractor shall submit to the Engineer proposed mix designs for concrete to be used, based on preliminary laboratory tests to determine proportion of cement, aggregates and water in the concrete conforming to the quality and strength requirements specified herein. Preliminary test results of at least three different mixes of each class of concrete with varied water cement ratios shall be submitted. The results of 7 days and 28 days cube tests shall be used to establish the ratios between 7 days and 28 days strengths. The Engineer may adjust in the ratio of fine to coarse aggregate in the mix for a certain work. Preliminary design of mixes and testing shall be the responsibility of the Contractor. The proportion of voids in the coarse aggregate shall be controlled and if it exceeds 45% than sand and consequently the cement content shall be increased by the Contractor without any charge. If the proposition is less than 40%, sand shall be decreased but not the cement.

6.05.2 MAXIMUM ALLOWABLE WATER CONTENT:

All concrete specimens shall be made, cured and tested in accordance with British Standard or ASTM Standard. A curve representing the relation between the water content and the average 28 days Compressive Strength or earlier strength at which the concrete is to receive its full working load shall be established for a range of values, including all the compressive strengths shown on the plans, The curve shall be established by at least four points each point representing average values for at least four specimens. The maximum allowable water content for the concrete shall be as determined from this curve and shall correspond to a strength 15% greater than indicated on the plans. No substitution shall be made

in the materials used in the work without additional tests in accordance with this procedure to indicate that the quality of the concrete is satisfactory.

6.05.3 SLUMP TEST:

The Slump for concrete, determined in accordance with PS No.422:1964 "Slump Test for Concrete" shall be minimum of 25 mm (1") and a maximum of 75 mm (3") provided the requisite strength is obtained. Corrective additions to remedy deficiencies in aggregate gradations shall be used only with the written approval of the Engineer. When such additions are permitted the materials shall be measured separately for each batch of concrete.

6.06 BATCHING AND MIXING:

6.06.1 Concrete shall be mixed by a mechanical batch type mixing plant with adequate facilities for accurate measurements and control of each material entering the mixer and for changing the proportions to conform to varying conditions of the work. The mixing plant assembly shall permit ready inspection of operations at all times. The plant and its location shall be subject to approval of the Engineer. However, if approved by the Engineer, Volumetric batching can be adopted, using cement by weight, at 20°C or 70°F according to the following table:

Class Mix.	Nominal	Cement		Sand Coarse		Aggregate	
		Lbs.	Kgs.	Cft.	Litre	Cft.	Litre
A	1:1:2	110	50	1 3	35	2 2	70
B	1:1 1/2:3	110	50	1 3/4	50	3 2	106
C	1:2:4	110	50	2 2	70	5	140
D	1:3:6	110	50	3 2	106	7 2	212
E	1:4:8	110	50	5	140	10	280

Water shall be measured for every batch with due allowance made for water already present in aggregates.

6.06.2 Batching units where used shall be supplied with the following items:-

- i) Weighing unit shall be provided for each type of material to indicate the scale load at convenient stages of the weighing operations. Weighing units shall be checked at times directed by and in the presence of the Engineer or his Representative and required adjustments shall be made before further use.
- ii) Water mechanism shall be tight with the valve interlocked so that the discharge valve cannot be opened before the filling valve is fully closed and shall be fitted with graduated gauge.
- iii) Discharge gate shall control the mix to produce a rib boning and mixing of cement with aggregates. Delivery of materials from the batching equipment to the mixer shall be accurate within the following limits:-

MATERIAL	PERCENTAGE BY WEIGHT
Cement	1/2
Water	1/4
Fine Aggregate	1
Coarse Aggregate	2

6.06.3 MIXING UNIT:

- i) Operations:
Mixers shall not be charged in excess of noted capacity nor be operated in excess of noted speed. Excessive mixing requiring addition of water to preserve required consistency shall not be permitted. The entire batch shall be discharged before re-charging.
- ii) Mixing time shall be measured from the instant water is introduced into the mixer drum containing all solids. All mixing water shall be introduced before one-fourth of the mixing time has elapsed. Mixing time for mixers of one cubic meter or less shall be 2 minutes; for larger than one cubic meter capacity mixers time shall be increased 15 seconds for each additional half cubic meter or fraction thereof. If an air-entraining agent is used, additional mixing time shall be allowed such as to provide the specified air-content.
- ii) Discharge Lock:
Unless waived by the Engineer device to lock the discharge mechanism, until the required mixing time has elapsed, shall be provided on each mixer.
- iv) No hand mixing under any circumstances even with extra cement shall be permitted. If during concreting, the mixing plant fails, the concrete already poured shall be removed, unless directed otherwise by the Engineer or his Representative.

6.07 SAMPLES AND TESTING:

6.07.1 GENERAL:

Test cubes of concrete shall be prepared and stored by the Contractor, in accordance with PS No.560:1965, as and when directed by the Engineer or his Representative. Test cubes be tested in a laboratory and the Contractor shall bear the charges for the same. Aggregates shall be tested as prescribed.

6.07.2 CEMENT:

Cement shall be tested as prescribed in Pakistan Standard or British Standard or ASTM Standard.

6.07.3 AGGREGATES:

Aggregates shall be tested as prescribed in relevant Pakistan Standard or British Standard 812. In addition, fine aggregates shall be tested for organic impurities in conformity with B.S. 812 or equal ASTM Standard or Pakistan Standard.

6.07.4 REINFORCEMENT:

Reinforcing bars shall be tested as prescribed in relevant Pakistan or British or ASTM Standards. Mesh Reinforcement shall be tested as prescribed in B.S.785 or ASTM A-185.

6.07.5 TESTING OF CONCRETE

- i) The Contractor shall provide for test purposes one set of six cubes taken for each class of concrete poured on each day. The Engineer or his Representative may, however, order for more cube tests if any irregularity is found in the concrete.
- ii) All test cubes shall be 150 x 150 x 150 mm (6"x6"x6") size.
 - iii) All test cubes of the same set shall be made from the same batch of concrete.
 - iv) Three cubes of the set shall be tested at 7-days and three shall be tested at 28 days or at such ages as directed by the Engineer or his Representative.
- v) All test specimens shall be made and cured in accordance with Pakistan Standard PS 560:1965 or British Standard B.S. 1881 or ASTM C-31.
- vi) Specimens shall be cured under laboratory conditions except that the Engineer or his Representative may require curing under field conditions.
- vii) All cube moulds shall be steel moulds perfectly true having all internal and the meeting faces machined to a smooth surface.
- viii) If the strength tests of the laboratory-controlled specimens for any portion of the work falls below the minimum allowable compressive strength at 28 days required for the class of concrete used in that portion, the Engineer or his Representative shall have the right to order replacement of the effected work.
- ix) All test cubes cast at site shall bear distinguishing mark showing serial number, date of casting, quality of concrete and place from where sample was taken and where that batch of concrete was placed in the structure. A proper daily record of test specimens made, test results obtained shall be maintained by the Contractor and weekly test results shall be submitted to the Engineer or his Representative.
- x) The Engineer or his Representative may require load tests for the part of the structure from where test specimens have shown unsatisfactory results at the cost of the Contractor. In the event that load tests indicate bad quality of concrete, measures as prescribed by the Engineer shall be taken to correct the deficiency at no additional cost to the Department. The nature, description and details of load test shall be determined by the Engineer and shall be binding on the Contractor.

6.08 TRANSPORTING AND PLACING CONCRETE:

- a. Concrete shall be conveyed and deposited as quickly as possible after mixing and shall proceed so that, as far as possible, a complete section of the work is done in one operation.
- b. Transport of concrete shall be in a manner approved by the Engineer's Representative and shall be so as to avoid segregation or loss of ingredients of concrete.
- c. All foundations and portions of work to be concreted shall be approved by the Engineer's Representative before concrete is poured.
- d. All forms and reinforcement shall be completed, cleared inspected and approved before pouring of concrete. No concrete is to be deposited till the Engineer's Representative has inspected and approved in writing all reinforcement, foundations, forms, details, positioning of all fixture and materials to be embedded in concrete, control levels and screeds, etc. and is satisfied with the arrangements the Contractors has made to efficiently proceed with the work such as sufficient labour, materials, plants etc. Such an approval will not relieve the Contractor from any of his obligations under this Contract. Water shall be removed from excavations before concrete is deposited.
- e. Placing of concrete shall not be permitted when, in the opinion of the Engineer's Representative, the sun heat, wind, cold, snow or limitations or facilities furnished by the Contractor prevent proper placing, finishing and curing of concrete.
- f. All concrete shall be thoroughly compacted and consolidated by means of Pneumatic or mechanical vibrators or other approved compacting method. Care shall be taken to avoid segregation due o excessive vibration. The Contractor shall maintain on site at all times one or more stand-by vibrators. Tapping or other external vibration of forms shall not be allowed, unless so directed by the Engineer's Representative. Compaction shall be done until the whole mass assumes a jelly like appearance and consistency with the water just appearing on the surface. Concrete shall be sufficiently tamped and consolidated around the steel rods, care taken that the vibrator does not touch steel or formwork and into all parts of the moulds in order that no voids or cavities are left. Steel shall not be disturbed during operations of concreting. Concrete shall be brought up in even layers not more than 150 mm (6") thickness and worked against side of forms to give a smooth and uniform surface. No excessive water shall be allowed to come out and lie on the surface of concrete. The concrete must be of such a consistency that after ramming, consolidating and tamping is completed, a thin film of water is just appearing on the surface.
- g. Hardened concrete, debris and foreign material shall be removed from interior of forms and from inner surface of mixing and conveying equipments.
- h. Runways shall be provided for wheeled concrete handling equipment, and such equipment shall not be wheeled over reinforcement, nor shall runways be supported on reinforcement.

- i. Concrete shall not be dropped freely from a height of more than 3.5 m (12 ft) in columns and 1.5 m (5 ft) elsewhere. In cases where an excessive drop is inevitable the Contractor shall provide spouts, down pipes, chutes, or side parts to forms with pockets which will let concrete stop and flow easily into the form without any risk of segregation. The discharge of the spouts, down pipes or chutes shall be controlled so that the concrete may be effectively compacted into horizontal layers not more than 300 mm (12") thick.
- j. Concrete is to be deposited as quickly as possible after mixing and to proceed continuously. Concrete which has attained its initial set or has contained its mixing water for more than 30 minutes shall not be allowed to be placed in the work.
- k. When concrete is laid on hard core, such as subgrade for floor slabs, or other absorbent material, the surface is to be watered, consolidated and, where specified, blinded before the concrete is deposited.
- l. Fresh concrete shall not be placed on previously laid concrete or on old concrete surfaces until the latter has been cleaned of dirt, scum and laitance by wire brushes. The clean surface shall then be thoroughly wetted and grouted with cement slurry as approved by the Engineer's Representative.
- m. Care shall be taken not to disturb newly placed concrete by vibrator, indirect loading or otherwise. No traffic or loading shall be allowed on the concrete until it has thoroughly set and hardened.
- n. Construction joints in concrete shall only be given at locations indicated on the drawings or as approved by the Engineer or his Representative. At the end of the day's work the concrete shall be finished off against a temporary shutter stop, which shall be vertical and securely fixed. Such stops shall be removed within 24 hours of placing of concrete. Construction joints not shown on the drawings shall be reinforced with steel bars or dowels, if deemed necessary by the Engineer or his Representative shall be furnished by the Contractor without any additional payment.
- o. No concrete shall be placed during rains or in inclement weather and all fresh concrete shall be suitably protected from rain-fall and excessive heat or cold.
- p. Should any part of the exposed surface present a rough uneven or imperfect appearance when the shuttering is removed. It shall be picked out to honeycomb depth and refilled and properly re-surfaced or entirely redone as per directions of Engineer or his Representative at the cost of the Contractor.
- q. On removal of the forms and before the skin has had time to harden, all faces of the concrete inside or outside, to be kept exposed shall be rubbed over with carborandum stone, and washed with cement to remove all marks, projections, hollows or any other defect. No extra payment shall be made for this work.
All exposed surfaces and lines of the concrete work are to be true and fair without cracks, bends, windings and distortions of all kinds, and if occurring, shall be removed without any extra charges by the Contractor. All un-plastered concrete works is to be fair face, smooth, pleasing and to the entire satisfaction of the Engineer or his Representative.
- r. A float or screed is to be worked over the exposed surfaces of all concrete work on the flat or curve, so as to render the surfaces perfectly smooth, clear, and to the necessary slopes or falls or as required to receive the floor or roof finishes, according to the drawings, and as directed by the Engineer or his Representative without any extra charges by the Contractor.

6.09 **PROTECTION AND CURING:**

All exposed concrete shall be cured. Curing shall be accomplished by preventing loss of moisture, rapid temperature change and mechanical injury or injury from rain or flowing water for a period of at least ten (10) days. Curing shall be started as soon as the concrete has hardened sufficiently for the surface not to be marked. Curing shall be done either by continuous sprinkling of water on the surface or by covering with sand, hessian, canvas or other approved fabric mats, which shall be kept continually wet. If required and so directed by the Engineer or his Representative, formed surfaces with forms in position shall also be cured by keeping all forms continually wet. As an alternative, curing of concrete, on all exposed surfaces which could not be kept covered, such as sides of the beams, under side of the slabs, may also be done by sealing concrete surfaces with curing compounds like "Paccacure" or equal so as to arrest loss of moisture from concrete, with approval of Engineer or his Representative. The Contractor shall take special care that curing of concrete is satisfactorily carried out and in accordance with methods specified herein and / or as instructed by the Engineer or his Representative. Any negligence in this regard may result in total rejection of such concrete works, which in the opinion of the Engineer or his Representative have not been adequately cured.

Minimum period of curing for any concrete shall be 10 days or more as directed by the Engineer. All concrete components of concreted structures shall be clearly marked with non-washable paints to indicate the date of placing concrete. During hot weather, curing shall be done even at night.

6.10 **FORMWORK:**

6.10.1 **General**

The formwork shall be inclusive of all labour, material, workmanship and alike. All form work and supports thereto shall be designed by the Contractor and relevant drawings shall be submitted to the Engineer and his Representative for approval before the work is put in hand. Such an approval shall not relieve the contractor from all the obligations of the contract or give rise to any claims.

6.10.2 **Making Forms**

The form-work for columns, beams, slabs lintels fins, shells, blocks, panels, purdees, surrounds for windows, and all other works whether to be precast or cast in situ shall be made of sound and properly seasoned timber or other approved material and shall be rigidly formed and designed by the Contractor to the shapes and forms as per drawings in

accordance with the best of the existing practices so as to be able to withstand, without displacement, deflection or deformation movements of any kind, the pressure of the moist concrete and all other loads. For concrete work to show an even finish the timber forms be properly lined with plywood or steel sheets to give a fair face concrete of a homogenous, perfectly even and smooth appearance in exposed surfaces of all beams, columns, walls, slabs, etc.

6.10.3 Rigid with Allowance for Camber and Bulges

It shall be fabricated and erected in position, perfect in alignment, levels and true to plumb and shape and securely braced so as to enable it to stand all weights, live and vibrating to be endured during placing of concrete and its subsequent hardening till the form work is struck. It shall be so sufficiently rigid as not to loose its form and shall be so made for bulging, and deflection as to give the finished concrete to the required lines, plumb, size and shape.

6.10.4 Exposed Surfaces Left Unplastered

For concrete work covered in this contract where concrete Surface is to be exposed in the finished work and left unplastered, the form-work shall be smoothly faced by using plywood sheets or lining the shuttering with smooth steel sheet or non-absorbent material like formica sheets or in any manner as approved by the Engineer or his Representative, so as to make a perfectly smooth surface of the finished concrete. Where any surface defects on the exposed concrete surfaces occur and which do not impair the structural performance, being in excess of the designed surfaces, and the architectural appearance of the work in the opinion of Engineer or his Representative, such defects may be removed by guniting and grinding with corborandum stone or in any other approved manner, at the cost of the Contractor, otherwise the whole or part of the work may have to be removed and remade good by the Contractor at his own cost. For precast concrete members the forms shall be rigid, exact, smooth and made of steel.

6.10.5 Materials and Labour

The Contractor shall supply all materials and labour, necessary for a good and speedily erection of form-work such as shuttering, planks, struts, bolts, stays, gangways, boards, fillets etc. and shall do all that is essential in executing the job in a workman like manner to the satisfaction of the Engineer.

6.10.6 Form Work not to Interfere or Injure Work

The form-work shall be so designed and arranged as not be unduly interfere with concrete, during its placing, and easy to be removed without injuring the finished concrete, wedges, clamps, bolts and the rods shall be used, when permitted and where practicable, in making the form work rigid and in holding it to true position.

6.10.7 Opening in Form-work

Wherever the Concreting is required to be carried out within forms of considerable depths, temporary openings in the side of the form shall be provided to facilitate the pouring and consolidation of the concrete. Small temporary openings shall be provided at the bottom of all forms to permit the removal of rubbish etc.

6.10.8 Openings and other details

Provision shall be kept in the form-work such as openings, recesses holes, pockets, fillets, etc for housing services and other architectural details in the finished concrete or on its surface and edges as shown on drawings or as directed by the Engineer or his Representative to fix all necessary inserts, dowels pipes, holdfasts etc. as shown on drawings or as directed.

6.10.9 Joints in Form-work

All joints in the formwork shall be sufficiently closed to prevent undue leakage of mortar for concrete surface not to be exposed in the finished work. The joints in the form-work for all concrete surfaces to be exposed in the finished work shall be close jointed and perfectly smooth so as not to allow any leakage of the mortar from the concrete; and show any appearance of leaking mortar on concrete surface.

6.10.10 Treatment and Inspection of Forms

All rubbish, particularly chipping, shavings, and sawdust etc. shall be removed from the interior of the forms, immediately before fixing of bars. Forms shall be coated with approved mould oil before reinforcement is placed. Surplus oil on forms and any oil on reinforcing steel shall be removed. Forms surface not exposed to view or normal watering may thoroughly be wetted with soap and water in place of oiling before placing concrete. If the forms are not used within 24 hours, a fresh coat of oil shall be given before placing of concrete.

6.10.11 Striking Shuttering

No struts or timbering which serve the purpose of supporting the shuttering or centering shall be struck and removed without direct permission from the Engineer or his Authorized Representative in writing and the work of striking and removal after the receipt of such permission shall be conducted under the personal supervision of the competent foreman in the employment of the Contractor and the Contractor shall hold himself fully responsible for any consequences whatsoever. In all cases the Engineer or his Authorized Representative will direct and control the minimum period of time for which the forms, shuttering or centering shall remain in place before being struck; but, for the general guidance of the contractor, when normal Portland Cement has been used in the work, the following are to be considered as the minimum periods in days for the main classes of work:

Removal of Shuttering	10 °C (50°F)	20 °C (70°F)
Beams sides, walls & Columns (unloaded)	03	02
Slabs soffits (props left under)	09	06
Removal of props to slabs	18	14

Beams soffits (props left under)	18	12
Removal of props to beams, and shuttering under shells.	24	18

The Engineer or his Representative may require, however, that any walings, soldiers, struts or other timbers or supports, the removal of which may cause the transference of load to the finished work, to be kept in place for three weeks after the placing of the concrete.

6.10.12 Injury or Damage.

The Contractor shall be responsible for any injury to the work and any consequential damages caused by or arising from the removal and striking of forms, centering and supports, due to striking too soon, and any advice, permission or approval given by the Engineer or his Authorized Representative, relative to the removal and striking of forms, centering and supports shall not relieve the Contractor from the responsibilities herein defined.

6.10.13 Treatment after Removal of Forms.

Any minor surface honey-combing or other irregularities are to be properly made good immediately upon the removal of the form-work and the surface made good to the satisfaction of the Engineer and his Representative. Any small voids shall be neatly stopped with cement mortar consisting of one part of cement to two parts of sand and the whole surface rubbed over with corborandum stone and cement wash and bring the whole to a smooth and pleasing finish and uniform colour.

No form-work shall be measured and paid for separately and shall be deemed to be included in the unit price of concrete whether cast-in-situ or precast and subsequently fixed in position.

6.11 FINISHING OF FORMED SURFACES

6.11.1 SPECIAL ARCHITECTURAL FINISHES

- i) Textured finishes - Textured form liners may be of form plastic sheet, wood sheet, metal, or other material. Liner panels shall be secured in forms by cementing or stapling, but not by methods which will permit impressions of nail heads, screw heads, washers, or the like to imparted to the surface of the concrete. Edges of textured panels shall be sealed to each other or to divider strips (if specified or shown) to prevent bleeding of grout. The sealant used shall be non-staining to the surface.
- ii) Aggregate transfer finishes - Aggregate transfer and other special finishes shall be produced using methods and materials in such a way as to duplicate sample panels prepared in advance.
- iii) Applied finishes - When special finishes are to be applied, the surface of the concrete shall be prepared to ensure permanent adhesion of the finish. If the concrete is less than about 24 hours old, it can be roughened with a heavy wire brush or scoring mechanically or by etching with dilute hydrochloric acid. After roughening the surface shall be washed free of all dust, acid, chemical retarder, and other foreign material before the final finish applied.

6.11.2 RUBBED FINISHES

The following finishes shall be produced to concrete with a smooth form finish. Where smooth rubbed finish is to be applied, the forms shall have been removed and necessary patching completed as soon after placement as possible without jeopardizing the structures.

- i) Smooth rubbed finish - Smooth rubbed finish shall be produced on newly hardened concrete not later than the day following from removal. Surfaces shall be wetted and rubbed with car texture are produced. No cement grout shall be used other than the cement paste drawn from the concrete itself by rubbing process.
- ii) Grout cleaned finish - No cleaning operation shall be permitted until all continuous surfaces to be cleaned are completed. Mix 1 part Portland cement cement and 1 1/2 parts fine sand with sufficient water to produce a grout having the consistency of thick paste. White Portland cement shall be substituted for a part of the grey Portland cement in order to produce color matching the color of the surrounding concrete, as determined by a trial patch. Wet the surface of the concrete sufficiently to prevent absorption of water from the grout and apply the grout uniformly with brushes or a spray gun. Immediately after applying the grout, scrub the surface vigorously with a cork float or stone to the surface and fill all air bubbles and holes. While the grout is still plastic, remove all excess grout by working the surface with rubber float, sack, or other means. After the surface whitens from drying (about thirty minutes at normal temperatures), rub vigorously with clean burlap. The finish shall be kept damp for at least 36 hours after final rubbing.
- iii) Cork floated finish - Remove from at an early stage, within 2 to 3 days of placement where possible. Remove ties . Remove all burrs and fins. Mix one part Portland cement and one part fine sand with sufficient water to produce a stiff mortar. Dampen wall surface. Apply mortar with firm rubber float or with trowel filling all surface voids. Compress mortar into voids using a slow - speed grinder or stone. if the mortar surface dries too rapidly to permit proper compaction and finishing, apply a small texture with a cork float using a swirling motion.

6.11.3 UNSPECIFIED FINISH

If the finish is not designated and applied finishes are also not indicated the following finishes shall be used as applicable:

- i) Rough form finish - For all concrete surface not exposed to public view.
- ii) Smooth form finish - For all concrete surfaces exposed to public view.

6.11.4 RELATED UNFORMED SURFACE

Tops of walls or buttresses, horizontal off-sets, and similar unformed surfaces occurring adjacent to formed surfaces shall be floated to a texture reasonably consistent with that of the formed surfaces. Final treatment on formed surfaces shall continue uniformly across the unformed surfaces.

6.12 **CONSTRUCTION JOINTS:**

Construction joints shall be located as indicated on the drawings and/or as approved or directed by the Engineer or his Representative. For slabs and beams construction joints shall be located at mid-point of the span unless a secondary beam intersects a main beam at the centre in which case the joints in the main beam shall be off set a distance equal to twice the width of the beam and provision for shear shall be made by the use of inclined reinforcement at the cost of the Contractor. Joint in columns shall be made at the underside of the deepest beam framing thereto. Beam stems shall be poured monolithically unless directed otherwise by the Engineer. Joints not specified or shown on the drawings shall be so located as to least impair the strength and appearance of the work. Except where indicated on the drawings no jointing shall be made in footings or foundations without written approval of the Engineer or his Representative. Construction jointing shall be at right angles to the member and shall be formed against firm stop boards. The stop boards shall be removed as soon as possible after placing the concrete but without the risk of movement of the concrete and the concrete surface shall be well brushed with a hard brush and washed off with a spray of water, two to four hours after casting, to expose the aggregates and provide a key for the next pour. In all liquid retaining structures and other sub-structures pits and trenches etc. PVC or any other approved water stops shall be provided at the construction joint in the manner shown on the drawings and/or approved by the Engineer or his Representative.

Whenever a section of concrete is left unfinished, for any reasons with the approval of Engineer's Representative, leaving a surface which will be hard set before additional concrete can be joined to it, dovetails, grooves or other bonds with the new work shall be provided at cost of the Contractor. Before depositing fresh concrete upon or against any concrete which has already set, the surface of the set concrete shall be roughened with a cutting tool, any laitance removed, thoroughly cleansed of all foreign matter, well watered and covered with cement grout, and special care shall be taken to ram the fresh concrete thoroughly up and against the set concrete; and, if deemed necessary by the Engineer or his Representative the joints shall be reinforced with steel bars or dowels to be all furnished and done by the Contractor without any additional payment.

6.13 **CONCRETE FLOOR SLAB FINISHING:**

6.13.1 **GENERAL**

Concrete slabs shall be finished as described herein. In preparation for finishing, floor slabs shall be struck off to the required level at or below the elevation or grade of the finished floors as shown on the drawings. Floors shall be leveled with a tolerance of 1 mm in 1 m (1/8" in 10 feet) except where drains occur in which case the floors shall be pitched to the drains as indicated on the drawings or as directed by the Engineer.

6.13.2 **MONOLITHIC FINISH**

All concrete surfaces in floors except where other finish is specified shall be finished by steel floats or straight edges to bring the surface to the required finish level shown on the drawings. While the concrete is still green but sufficiently hardened to bear a man's weight without deep imprint it shall be wood floated to a true even plane with no coarse aggregate visible. Sufficient pressure shall be used on the wood floats to bring moisture to the surface. The concrete shall then be hand troweled to produce a smooth impervious surface free from trowel marks. If necessary, the process shall be repeated so that the final finish shall produce a ringing sound from the trowel. No separate payment shall be made for finishing floor slabs in the fore mentioned manner.

6.13.3 **CONCRETE TOPPING**

Where indicated on the drawings base slab under concrete topping shall receive a screeded finish. After the base slab is thoroughly cured and when directed concrete topping shall be laid to the thickness as indicated on the drawings in alternate panels of suitable sizes as directed by the Engineer or his Representative.

6.14 **ANCHOR BOLTS, INSERTS, SLEEVES, CHASES, RECESSES STEEL FRAMES ETC:**

The Contractor shall furnish and place in position accurately shown on drawings, all inserts, sleeves, chases, recesses, etc., supplied by himself or other Contractors, as directed, by the Engineer and full cooperation and co-ordination shall be maintained with other Contractors, sub-contractors in this regard.

6.15 **WATERPROOF CONCRETE:**

Wherever specified on the drawings all liquid or water retaining structures and those subject to water pressure shall be executed with approved waterproof concrete. The water proofing compound shall be of the approved type and shall be mixed with the concrete in strict accordance with the manufacturer's directions and/or as directed by the Engineer or his Representative.

6.16 **CLEANING AND REMOVAL OF RUBBISH:**

On completion of works herein the Contractor shall remove all concrete debris, rubbish, shuttering materials, scrapes etc., from the vicinity of the structures completed. All areas shall be cleaned to the satisfaction and approval of the Engineer or his Representative.

6.17 **COORDINATION:**

The Contractor shall provide chases and openings required for other sections of the work and will co-operate and coordinate with other trades in placing their pipes, ducts, reglets and other built-in-items as the work proceeds.

6.18 **EXTERNAL EXPOSED CONCRETE SURFACE:**

All external exposed un-plastered concrete surfaces of cast in situ or precast units shall be given smooth or pattern finish as shown in the finishing schedule or as directed by the Engineer or his Representative. No separate payment shall be

made to the Contractor for this work and it shall be included in the item rates of the respective concrete items in the bill of quantities.

6.19 PARTICULAR SPECIFICATIONS FOR CONCRETE

- a) Allowable bearing pressure of soil for foundation is marked on the drawing of the foundation. It is to be checked that no foundation is placed on the soil with a lower bearing capacity. In cases any weaker strata is encountered at any level the matter is to be reported to the Engineer for necessary changes in footings.
- b) Level of foundations as indicated on the drawings may be varied at site to reach the suitable strata. This matter is to be decided by the Engineer at site.
- c) Before concreting, the excavated surface to receive the concrete should be cut to proper levels. All loose soil is to be removed.
- d) Minimum strength requirements of various concrete mixes at 28 days actually being used for work using ordinary Portland cement shall be as follows:-
- | | | |
|---------------|-----------|---------------------------|
| Concrete Mix: | 1:1:2 | - 4500 p.s.i. (Class 'A') |
| | 1:1 1/2:3 | - 3750 p.s.i. (Class 'B') |
| | 1:2:4 | - 3000 p.s.i. (Class 'C') |
| | 1:3:6 | - 1500 p.s.i. (Class 'D') |
| | 1:4:8 | - 1000 p.s.i. (Class 'E') |
- e) All R.C.C. work shall be in 1:2:4 concrete mix unless otherwise indicated for a richer mix on the drawing or specified.
- f) All concrete is to be thoroughly vibrated mechanically:
- Any concrete failing to meet the specified strength or not formed as shown on drawings, concrete out of alignment, concrete with surfaces beyond require tolerances or with defective surfaces which cannot be properly repaired or patched in the opinion of Engineer=s Representative shall be removed and replaced at Contractor=s expense. The Engineer=s Representative may reject any defective concrete and order it to be cut out in part or in whole and replaced at the Contractors expense. Only in case of minor surface defects the Engineer=s Representative may approve a surface treatment immediately after from removal.
 - All ties and bolt holes and all repairable defective area shall be patched immediately after removal.
 - All honeycombed and other defective concrete shall be remove down to sound concrete. The area to be patched and area at least 150 mm wide surrounding it shall be dampened to prevent absorption of water from the patching mortar. A bonding grout shall be prepared using a mix of approximately 1 part cement to 1 part fine sand passing a No. 25 B.S. Sieve, shall be mixed to the consistency of thick cream and shall then be well brushed into the surface.
 - The patching mixture shall be made of the same material and of approximately the same proportions as used for the concrete, except that the coarse aggregate shall be omitted and mortar shall consist of not more than 1 part cement to 22 parts sand by damp loose volume. White Portland cement shall be substituted for a part of the grey Portland cement on exposed concrete in order to produce a color matching the color of the surrounding concrete, as determined by a trial patch.
 - The quantity of mixing water shall be not more than necessary for handling and placing. The patching mortar shall be mixed in advance and allowed to stand with frequent manipulation with a trowel, without addition of water, until has reached the stiffest consistency that will permit placing.
 - After surface water has evaporated from the area to be patched, the bond coat shall be well brushed into the surface. When the bond coat begins to lose the water sheen, the premixed patching mortar shall be applied. The mortar shall be thoroughly consolidated into place and struck off so as to permit initial shrinkage, it shall be left undisturbed for at least 1 hour before being finally finished. The patched area shall be kept damp for 7 days. Metal tools shall not be used in finishing a patch in a formed wall, which will be exposed.
- g) For heavy concrete members the form work is to be properly designed and approved by the Engineer.
- h) Shuttering should not be struck earlier than the time specified unless otherwise approved by the Engineer.
- i) 18 gauge G.I. binding wire to be used for securely binding the reinforcing bars to avoid dislocation or displacement during concreting.
- j) Clear cover to main reinforcement in concrete members be as follows:-
- For slabs, projections chajjas, fins, walls, staircases precast slabs. 3/4"
 - For beams, Columns, all members of water tank on the side in contact with water. 1 1/2"
 - For foundations, retaining walls and foundation beams. 2"
- k) All the reinforcing bars are to be properly placed as shown on the working drawings. Steel chairs and concrete spacer blocks are to be used without any extra cost. Concrete spacer blocks are to be properly cured to avoid their damage during concreting, thereby causing displacement of bars. Holes made by bolts etc. introduced for keeping the shuttering intact should be properly treated after striking the shuttering. No such holes shall be allowed in walls of water retaining structures and earth retaining walls.
- l) All bent up bars in slabs are to be properly secured in position. Workers or trollies shall not be allowed in any case over the reinforcement mesh.

m) Special care is to be taken to see that all expansion joints shown on the drawings are made in perfect straight line and treated as specified.

n) Construction joints in beams and slabs shall be located at the centre of the span (such that a proper seat is formed for the next part to be cast); unless otherwise indicated on drawings or approved by the Engineer.

o) DPC

The Concrete mix of DPC will be CC 1:2:4 as specified in this chapter.

To protect the dampness water proofing agent APudlo@ or any other water proofing agent as approved by the Engineer will be mixed in CC 1:2:4 @ the ratio of 5 lbs per bg of cement. The DPC will be cured for at least 10 days.

6.20 MEASUREMENT AND PAYMENT

All the concrete work shall be measured net as per execution at site in square or cubic feet for the related items and shall be paid at the rate entered in the BOQ appended to the contract in accordance with the conditions of contract. The rates are inclusive of all type of form-work, its erection and removal, all scaffolding, cost of mixing and batching plants, all T&P required for executing and placing the concrete work in position and Water Stopper, Bitumen Coating etc. Defective and honey-combed work will not be measured & paid and will be liable to be rejected and redone at contracts' cost.

SECTION - 7

7.0 STEEL REINFORCEMENT

7.01 SCOPE OF WORK:

The work covered by the section of the specification consists of furnishing all materials, tools, labour and in performing all operations in connection with the providing, straightening cutting, bending, binding, fixing, including binding wire, chairs, pins, spacer block complete in strict accordance with this section of the Specifications, the applicable drawings, approved bar bending schedule, and the terms and conditions of the Contract.

7.02 MATERIALS:

A. Reinforcing steel to be new billet stock of mild steel (plain bar), hard grade (deformed bar) and Ribbed Tor steel as specified on the drawings and shall conform to British Standard Specifications or equivalent ASTM or Pakistan Standard.

B. The Contractor shall furnish to the Engineer's Representative Manufacturers' mills certificate to guarantee that steel meets the standard, specifications requirements and minimum certified yield stresses as follows: -

i) Mild Steel plain bars conforming to B.S.S. 15 or B.S.S. 4449 or PS-231-1962

a) Tensile Strength - 438 to 517 N/Sq.mm (28 to 33 tons/Sq.in).

b) Yield Strength - 250 N/Sq.mm (16 Tons/Sq.in)

c) Elongation - 16% to 24% (av. 20%).

ii) Hard grade deformed bars conforming to ASTM, A-15-85 T. or PS-605-1962

a) Tensile Strength - 560N/Sq.mm (35.7 Tons/Sq.in).

b) Yield Strength - 350 N/Sq.mm(22.3 Tons/Sq.in).

c) Elongation - 1100 000 x %

Tensile Strength

iv) Ribbed Tor steel conforming to B.S. 4461

a) Tensile Strength - 490 N/Sq.mm(70,000 lbs/Sq.in).

b) Yield Strength - 420 N/Sq.mm(60,000 lbs/Sq.in).

c) Elongation - 14.5%

C. All steel to be true to the Standard Specifications with regard to bend ability specially the hard grade deformed bars under 19 mm (3/4") dia. shall be capable of being bent cold through 90 degree round a bar of four times its own diameter without fractures or injury of any kind. In case of deformed bars over 19 mm (3/4") dia. and under 28 mm (1-1/8") dia. round a bar of 6 times its own diameter.

D. 18 gauge galvanized wire shall be used for binding the steel reinforcement.

7.03 TESTING:

Reinforcement shall be obtained only from manufacturers approved by the Engineer's Representative.

If and when required samples shall be tested for above specification in an approved laboratory when required by the Engineer or his Representative and all costs of such tests shall be borne by the Contractor.

7.04 STORAGE

Reinforcing bars shall be stored on platforms above surface of ground and be free from scales, oil, structural defects prior to placement in works. Rusted or dirty steel bars shall not be used in the works unless brushed and cleaned by proper steel wire brushes and after being approved for use by the Engineer or his Representative.

7.05 REINFORCEMENT CUTTING AND PLACING

A. All reinforcement steel shall be cut and bent cold in strict accordance with bar bending schedules approved and drawings supplied by Engineer. The Contractor shall prepare bar bending schedule from approved structural working drawings and instructions to be provided to him by the Engineer. The bending schedules shall be drawn on approved forms and submitted to the Engineer or his Representative for checking and approval. The steel reinforcement shall be cut and bent to sizes as per drawings and approved bending schedules. In case any bars, cut, bent or even fixed in position are found incorrect in dimensions size or shape according to the requirements of the drawings and instructions of Engineer, the Contractor shall replace such steel bars cut bent or fixed in position by correct sized bars at his own cost and no extra payment shall be made to the Contractor on such account. The system of holding bars in place shall ensure that all steel

in top section will support weight of workmen without displacement or distortion. Suitable spacers and chairs as approved by the Engineer or his Representative shall be used for supporting and spacing purposes of bars. In case any bars are bent or displaced they shall be straightened or replaced prior to pouring. All reinforcement bars within the limit of a days pour shall be in place and firmly tied with 18 gauge G.I. wires. Bars with kinks or bends not shown on drawings shall not be used.

- B. Where indicated in the drawings, mesh shall be of the sizes as shown on drawings and conform to British Standard B.S.785. Mesh reinforcement when used in slabs shall be supported at proper elevations by standard accessories. In slabs on ground, pre cast concrete blocks may be substituted for chairs.

7.06 LAPS AND SPLICES

- A. No splicing of bars shall be allowed at position other than shown on the drawings. All lap lengths shall be of the minimum sizes as indicated on the drawings and in no case shall lap length be less than 40 times the diameter of the bigger lapping bars for nominal M.S. bars. Hard grade bars and tor steel shall have laps of 50 time the bigger diameter of lapping bars. Splices of adjacent bars shall be staggered unless approved otherwise by the Engineer or his Representative.
- B. All reinforcing steel fixed in position shall be inspected by the Engineers Representative and no concrete shall be poured until steel placement has been approved by the Engineers Representative. For inspection purposes the Contractor shall give to the Engineers Representative reasonable notice before the scheduled pouring time. Clear concrete cover to reinforcement steel shall be as indicated on the drawings/specified.

7.07 MEASUREMENT AND PAYMENT

- A. The quantity to be paid for shall be the calculated in theoretical number of metric ton of reinforcement steel bars or mesh as determined from the approved bar bending diagrams and incorporated in the concrete and accepted, except when reinforcement is paid for under other items.
- B. The weight of plain or deformed bars will be computed from the theoretical weight of plain round bars of the same nominal size as shown in the following tabulation:

Size in.	Weight in lbs per ft.	Size in.	Weight in lbs per ft.
1/4	0.167	3/4	1.502
3/8	0.376	7/8	2.045
1/2	0.668	1	2.670
5/8	1.043	1 1/8	3.380

- C. Clips, ties, separators, and other material used for positioning and fastening the reinforcement in place, and structural steel, shall not be included in the weight calculated for payment under this item. If bars are substituted upon the Contractor's request and as a result more steel is used than specified only the amount specified shall be included.
- D. When laps are made for splices, other than those shown on the drawings or required by the Engineer and for the convenience of the Contractor, the extra steel shall not be measured nor paid for.
- E. When continuous bars are shown on the drawings, without the splices being shown, the necessary steel in the splices will be paid for on the basis of the individual bars not being shorter than 40 ft.
- F. The accepted quantity measured as provided above shall be paid for at the contract unit price for the items listed in the Bill of Quantities which price and payment shall be full compensation for furnishing materials, labour, equipment and incidentals necessary to complete the item.

ARCHITECTURAL AND FINISHES WORKS
SECTION - 8

8.0 BLOCK MASONRY

8.1 SCOPE

The work under this section of the specifications consists of furnishing all plant, labour, equipment, appliances and materials and performing all operations in any floor and at any height in connection with the supply and installation of ordinary cement concrete solid and hollow block masonry work including wall ties, anchors, damp-proof courses, complete in strict accordance with this section of the Specifications and applicable drawings, and subject to the terms and conditions of the Contract.

8.2 APPLICABLE STANDARDS

Latest editions of following Pakistan, British and ASTM Standards are relevant to these specifications wherever applicable.

8.2.1 Pakistan Standards

- 232 Ordinary Portland cement.
- 419 Properties & Specifications of blocks

8.2.2 ISO (International Standardization Organization)

- R.679 Method of testing strength of cement compressive and flexural strengths of plastic mortar.
- R.680 Chemical analysis of cements - Main constituents of Portland Cement.
- R.681 Chemical analysis of cement - Main constituents of Portland Cement.

- 8.2.3 **ASTM (American Society for Testing and Material)**
 - C.144 Aggregate for Masonry Mortar.
 - C.331 Light weight Aggregate for Concrete Masonry Units.
 - C.404 Aggregates for Masonry Grout.
 - C.426 Drying Shrinkage of Concrete Block.
 - C.476 Mortar and Grout for Reinforcement Masonry.
 - C.149 Bond Strength of Mortar to Masonry Units.

- 8.2.4 **BSI (British Standards Institution)**
 - 743 Materials for Damp-proof Courses.
 - 1243 Specification for Metal Ties for Cavity wall Construction.
 - 4887 Mortar Plasticizer
 - 121 Pt-1 Brick and Block Masonry
 - 122 Pt-2 Walls and Partitions of Blocks and Slabs.

8.3 MATERIALS

8.3.1 For Block

Cement, aggregates and water for concrete blocks shall conform to the requirements as specified in the section for Plain and Reinforced Concrete.

8.3.2 For Mortar

8.3.3 Sand

Sand for mortar shall comply with the requirements for BS-1200. It shall be graded in accordance with the following table and the various sizes of particles shall be uniformly distributed.

SIEVE SIZE (NO.)	PERCENT PASSING BY WEIGHT	
	MIN	MAX
# 4	100	-
# 8	95	-
# 16	70	100
# 30	40	75
# 50	10	35
#100	2	15
#200	0	0

Sand up to 0.0025 inch shall not be more than 8% by weight of the total.

8.3.4 Cement:

Cement shall be Ordinary Portland Cement conforming to BS-12.

8.3.5 Water:

Water shall be clean and free from any harmful impurity. Where the quality of the water is doubtful, it shall be tested in accordance with BS- 3148.

8.3.6 Additives:

Additives where used, shall be proprietary products used in the proportions and manner recommended by the manufacturer. The additives shall in no way adversely affect the mortar strength or contain chemicals, which may be harmful to other building materials. To add gypsum to cement is strictly forbidden.

8.3.7 Mortars and Grout:

Materials for mortar, sand binding agent and water, shall be mixed by volume or by weight for at least 3 minutes with the minimum amount of water to produce a correctly mixed mortar or grout of workable consistency in a mechanical batch mixer. For small jobs, hand mixing may be permitted, the ingredients being mixed with sufficient water to produce a correctly mixed workable mortar.

Mortar shall be as strong, but no stronger than the materials it bonds together: Mortars shall be mixed in batches, which can be used within a period before the setting process commences. Once a mix begins drying off, it shall be rejected. No ingredients shall be added to it once the setting process has begun.

8.3.8 Reinforcement:

For reinforcement refer specification section no. 2200.

8.4 CONCRETE BLOCK MAKING

8.4.1 The Solid and Hollow blocks shall be factory manufactured/fabricated and be machine moulded. The block making machines shall be of the standard approved by the Engineer. They shall be operated according to the instructions laid down by the manufacturers. The contractor shall submit samples/literature of various manufacturers for Engineer's approval. The contractor should note that only blocks supplied by the approved manufacturer(s) shall be allowed to be used in this project.

8.4.2 The blocks shall be continuously water cured by sprinkling water for a minimum of 10 days and covered between sprinkling operations with 4 mils thick polyethelene sheeting. After 10 days water curing period the blocks shall be air-dried. Under no circumstances will blocks be used in the work until they are completely dry. During curing period no surfaces of the block will be allowed to dry.

8.4.3 Cured concrete blocks shall be stored off the ground, stacked on level platforms which allow air circulation under stacked units. Units shall be covered and protected against wetting.

- 8.4.4 Care shall be exercised in the handling of all concrete blocks. No damaged blocks shall be used in the work.
- 8.4.5 The hollow blocks shall be manufactured as per pattern shown on the drawing. These block units shall be provided by the Contractor for use where required in building structures from approved type of materials. Units shall have uniformly fine smooth surfaces of uniform colour. These shall be free of any honey combing or other imperfections or deformations, all edges true and straight, and at right angles with each other and without any chipped or otherwise broken edges.
- 8.4.6 The blocks cast on different dates shall be stacked separately and must be labelled showing the date on which they were cast.
- 8.4.7 Reinforced cement concrete hollow block masonry shall be provided where shown on the drawings. Hollow block manufactured by moulding machine shall have well formed cavities, sharp and well defined edges and corners, smooth surfaces without any imperfections or deformations.

8.5 PROPERTIES OF BLOCKS

- 8.5.1 All blocks shall be of the size and shape required to complete the work shown in the Drawings or as instructed by the Engineer.
- 8.5.2 The cement, sand and coarse aggregate shall be volume batched and their proportion may be adjusted so as to provide the concrete of the required strength when tested and shall be mixed in a concrete mixer in accordance with clause 5.4 of the section 'Plain and Reinforced Concrete'.
- 8.5.3 All blocks shall comply with ASTM 1988 edition. The compressive strength of various solid and hollow blocks shall be as follows:

S.NO	TYPE OF CONCRETE MASONRY ASTM 1988 EDITION	COMPRESSIVE STRENGTH Psi AVERAGE OF 03 UNITS (MPa)		LOCATION INDIVIDUAL UNIT
1	Solid load bearing Masonry Units Masonry units (ASTM-C-145-85)	1800 (12.4) 1200 (8.30)	1500 (10.4) 1200 (8.30)	Exposed to Frost action
2	Solid/Hollow non Load bearing Masonry units	600(4.14)	500 (3.45)	Not exposed to moisture & weather
3	Hollow load bearing masonry (ASTM-C-90-85)	1000 (6.90) 700 (4.80)	800 (5.50) 600 (4.10)	Not exposed to moisture & weather

- 8.5.4 The Contractor shall provide test certificates providing the average minimum crushing strength of the blocks prior to the commencement of the construction. Further test certificates shall be provided as required by the Engineer, to ensure that all batches of blocks have the minimum specified crushing strength.
- 8.5.5 A laboratory approved by the Engineer shall carry out the test. Evidence shall be produced that the block manufacturer has an efficient method of quality control. The Engineer will require to test samples of blocks periodically and the Contractor shall make necessary arrangements accordingly. The method of sampling for all tests shall be in accordance with.
- 8.5.6 All properties or specifications of blocks, not explained in these Specifications shall comply with the requirements of ASTM 1988 edition as directed by the Engineer.

8.6 SUCTION RATE

The Contractor shall, at his own cost, satisfy the Engineer that the suction rate of the block when determined in accordance with Appendix "A" of BS 3921 does not exceed 20 g/dm²/ min. or that the Contractor is able to adjust it so that it does not exceed this value on site.

8.7 SOLUBLE SALT CONTENT

For exposed block work, the contents by weight percent of soluble sulphate, calcium, magnesium, potassium and sodium radicals, shall not exceed 0.30, 0.10, 0.30, 0.03 and 0.03, percent respectively when ascertained in accordance with BS 3921, at the cost of the Contractor.

8.8 REINFORCING AND ANCHORS OF BLOCK MASONRY

Unless otherwise stated reinforcing and anchors shall conform to undermentioned sizes:

- 8.8.1 Joint reinforcing shall be 1.32mm (0.05-inch) diameter mild steel wire mesh design, galvanized after fabrication. Steel wire woven into 12mm mesh 75mm wide. Reinforcing bar anchors shall be 250mm dia. Deformed bar minimum 10 inch long.
- 8.8.2 Two 6mm dia bar shall be provided at every fourth course for anchoring of block masonry to columns. Two 10 mm bars at every fourth horizontal course shall be provided for anchoring masonry walls to plinth beam/floor beam, as shown on the drawings.
- 8.8.3 Dovetail anchors and slots (if used as an alternate anchorage) shall be not less than 18 gauge galvanized steel.

8.9 ERECTION

- 8.9.1 Blocks shall be laid true to line, level and laid in accurately spaced courses in stretcher bond with vertical joints of each course located at centre of units in alternate courses below. Vertical joints shall be buttered in the entire height of blocks. Each course shall be bonded at corners and at intersections of walls and shall be properly bonded. Courses of block shall be kept plumb throughout and corner reveals shall be true and in plumb.

Standard width of mortar joints for both horizontal and vertical joints shall be 10mm (maximum). Mortar joints in walls shall have full mortar coverage on vertical and horizontal faces between the blocks. Mortar joints on wall including struck joints, shall be thoroughly compacted and pressed tight against the edges of the blocks with proper tools. Blocks terminating against soffits of beam or slab construction shall be wedged tight with wedges and the joints shall be packed solidly with mortar between the top of the block and the bottom of slab or beam. Control expansion joints shall be kept free from mortar or other debris.

Unless otherwise shown on the drawings or specified by the Engineer, the spaces around doorframes and other material or built in items shall be solidly filled with mortar. Spaces around the door and window holdfasts shall be filled in with Class 'C' concrete. Work required to be built in with masonry including doorframe anchors, wall plugs, and dovetail anchors and accessories shall be built in as the erection progresses.

8.9.2 The block work shall be carried up in a uniform manner and no portion shall be carried more than one meter above the adjoining one at any time. All masonry shall be kept strictly true and square and the whole properly bonded together and levelled round each floor.

8.9.3 Sleeves, Chases, holes, sinking and mortices for other trades shall be correctly located and formed to the sizes as required by the relevant trades. Chiseling of completed walls or the formation of holes shall only be carried out with the approval of the Engineer.

8.9.4 Walls of blocks indicated, as being non-load bearing shall be constructed on the in situ concrete floor slab unit after the floor formwork is struck and the concrete has obtained sufficient strength to support their weight. Tothing into load-bearing walls shall not be permitted.

8.9.5 All bolts, anchors, ties, pipe sleeves, flushing metal attachments, lintels and the like required to be built into the work shall be correctly inserted and executed as the work proceeds.

Walls or partitions abutting concrete columns or walls shall be securely anchored and tied with metal anchors or ties at not more than 450mm vertical centres. Wall ties cast in with concrete shall be bent down after the removal of formwork and shall be securely jointed into the mortar beds of walling.

8.9.6 Care shall be taken during construction of cavity walls so as to avoid the filling up of cavity with mortar. G.I. flashing and weep holes shall be provided wherever specified on the drawings or as per the instructions of the Engineer. Weep holes will be formed by oiled rods, removed after the mortar is set, at specified locations.

8.10 SCAFFOLDING

Contractor shall provide safe scaffolding of adequate strength for use of workmen at all levels and heights at his own expense. Scaffolding which is unsafe in the opinion of the Engineer shall not be used until it has been strengthened and made safe for use of workmen. Cost of scaffolding etc., shall be included by the Contractor in the unit rate for masonry items.

Damage to masonry from scaffolding or from any other object shall be repaired by the Contractor at his own cost.

8.11 JOINTING

Jointing is the forming of joints as work proceeds. Joints shall be as follows:

8.11.1 Exterior exposed joints shall be tightly formed to a weather joint with the point of the trowel.

8.11.2 Interior exposed joints shall be tightly formed to a concave joint.

8.11.3 Joints which are subsequently covered with plaster or other finish materials shall be struck flush.

8.12 TOLERANCES

All block work shall be erected plumb and true to line and level with the maximum variation in any storey height or any length of wall being one mm in one meter. The maximum tolerance in the length, height or width of any single masonry unit shall be ± 3 mm.

8.13 DAMP PROOF COURSE

Damp-proof course shall be laid on an even mortar bed, free from projections, which may puncture the material. Where the damp-proof course is to be stepped, only flexible membrane shall be used. All damp proof course, unless otherwise specified, shall consist of class 'C' cement concrete 50mm thick, mixed with 2.5 kg. of pudlo per bag of cement or other approved quality water proofing compound as per manufacturer's specifications and shall be laid at required levels as per drawings and instructions of the Engineer. The D.P.C shall be tamped consolidated, levelled, edges and corners made to the requirements of concerned drawings including finishing and curing complete.

8.14 SOLID BLOCK WORK AROUND OPENING OF HOLLOW MASONRY

Around all openings in hollow block masonry, the Contractor shall provide solid block work of same thickness as that of hollow block masonry wall and of width as indicated on the Drawings. Solid block shall be laid around openings in such a manner that these are bonded integrally with hollow block masonry.

8.15 REINFORCED HOLLOW BLOCK MASONRY

Where specified on the Drawings, reinforced hollow block masonry shall be provided. Horizontal and vertical reinforcement shall be cold worked deformed bar. Two bars of (8mm) diameter shall be provided at every third horizontal course at 600mm centers, while the vertical reinforcement shall be two bars of (12mm) diameter at 800mm centers. Bars shall be anchored and held firmly vertical in respective beams and columns in the manner shown in shop Drawings. The reinforced hollow part of the block wall shall be solidly filled with Class 'D' concrete at intervals of one meter maximum height as the laying of block masonry work proceeds. The filled concrete shall be consolidated thoroughly by rodding to avoid formation of voids. Contractor shall submit shop drawings of anchoring and placing of reinforcement in hollow block masonry for approval of the Engineer.

8.16 CURING AND REPAIRS

8.16.1 All block masonry shall be water cured and shall be kept wet for at least seven days, by an approved method, which will keep all surfaces to be cured continuously wet. Water used for curing shall meet the requirements of the specifications for water used in the manufacture of blocks.

8.16.2 If, after the completion of any block masonry, the work is not in alignment or level, or does not, conform to the lines and grades shown on the Drawings or shows a defective surface, it shall be removed and replaced by the Contractor at his expense unless the Engineer grants permission, in writing, to patch or replace the defective area.

8.17 MASONRY SHORT OF HEIGHT

In case of different thickness of slab in different areas or rooms or for any other reasons, whatsoever if chiseling of masonry is required, the Contractor shall do so at his own cost. Where for any reason whatsoever, the height of the wall is short of ceiling height; the actual height shall be made good with Class 'C' nominal mix concrete. This concrete shall neither be measured nor be paid under item of concrete but will be paid for under the item of wall masonry. Similarly where the lintel heights are such that the Contractor has to chisel the masonry or provide cast-in-place concrete to make up the height of the course, no payment will be made for chiseling, but where such cast-in-place concrete is provided, payment for the same will be made at the unit rate of masonry.

8.18 MEASUREMENT AND PAYMENT

8.18.1 General

Except otherwise specified herein or elsewhere in the Contract Documents, no measurement and payment will be made for the under mentioned specified works related to the relevant items of the Bills of Quantities. The cost thereof shall be deemed to have been included in the quoted unit rate of the respective items of the Bills of Quantities.

18.1.1 Chiseling of masonry, wherever required.

18.1.2 Cement sand mortar used in laying blocks, curing of masonry works and making of weep holes.

18.1.3 Providing and filling Class 'D' Concrete in the cavity of hollow block masonry.

18.1.4 Providing and laying damp proof courses including damp proof materials and GI sheet flashing within cavity wall.

8.18.2 Solid Block Masonry

8.18.2.1 Measurement:

Measurement for acceptably completed works of respective type of solid block masonry will be made on the basis of number of sq meters provided and installed in position as shown on the drawings or as directed by the Engineer. Each measurement shall be taken to the nearest cm. All openings left in the masonry wall shall be deducted. Steel reinforcing bars, joint reinforcing bars, dovetail anchors on any horizontal/vertical reinforcement in hollow/solid block masonry shall be measured separately under relevant Section of Specifications i.e. 2200 and 3000.

8.18.2.2 Payment:

Payment will be made for acceptable measured quantity of respective type of solid block / Hollow Block masonry work on the basis of unit rate quoted in the Bills of Quantities and shall constitute full compensation for all the works related to the item. Steel reinforcing bars, joint reinforcing bars, dovetail anchors on any horizontal/vertical reinforcement in hollow/solid block masonry and Including DPC shall not paid separately.

SECTION - 9

9.0 PLASTERING

9.01 Scope of Work:

The work covered by this section of the Specifications consists of furnishing all plant, labour, appliances, and materials and in performing all operations in connection with the installation of plastering complete in strict accordance with this section of the Contract.

9.02 General

Except as may be otherwise shown or surfaces specified all plaster surface shall include walls, partitions jambs, returns, reveals, backs of recesses and jambs and heads of windows and doors and all the soffits, alcoves unless otherwise specified or shown on the drawings.

9.03 Materials:

- a) "WATER" as specified in respective section.
- b) "CEMENT" shall be ordinarily Portland Cement and shall conform to B.S.S.12.
- c) "SAND" shall be from approved source and free from dust and salt as specified in Section on concrete.
- d) "METAL LATH" shall be expanded metal not less than 9" wide strips, and weighing at least 2.5 lbs, per square yard or as directed by the Engineer.
- e) "CORNER LATH" shall be strips 6" wide bent to form two 3-inches wings.
- f) **Lime:** (To be used for putty)
 - i. Hydrated lime shall conform to British Standard BS-890 Class A, with the further requirement that the total free (unhydrated) calcium oxide (CaO) and magnesium Oxide (MgO) shall not exceed 8 percent by weight, calculated on the "as received" basis.

- ii. Quicklime (pulverized) shall conform to British Standard B.S.890 A. Pulverized quicklime shall pass a No.20 sieve, and at least 90 percent shall be used throughout the work. After slaking to a putty, the pulverized quicklime shall have a plasticity figure of not less than 200 when tested in accordance with ASTM Standard methods of Test C 110, and at the end of 72 hours the total free (unhydrated) calcium oxide (CaO) and magnesium oxide (MgO) in the hydrated product shall not exceed 8 percent by weight, calculated on the basis of the lime solids in putty.
- g. **Lime Putty** shall be made from hydrated lime, except that quicklime may be used when adequate time and facilities are available for aging. Suitable precautions shall be taken to protect the putty from exposure to the sun and to prevent excessive evaporation when stored. Lime putty prepared from quicklime shall be allowed to cool completely before using. Lime putty shall be prepared as follows:
 - i) Quick lime (pulverized) shall be slaked in suitable large batches, and with enough water to form a thick cream. During cold weather, precautions shall be taken to maintain the heat and prevent premature cooling during the process of hydration. The slaked quicklime shall be passed through a No.10 sieve and stored for at least 72 hours before using. When the use of lump quicklime, slaked on the job, in lieu of pulverized quicklime, is specifically approved for plastering, the cooling and aging period shall be not less than 14 days.
 - ii. Hydrated lime shall be machine-mixed with water to form putty and shall be allowed to stand for at least 15 minutes before using.

9.04 MIXING OF MORTAR

Except where hand-mixing of small batches is approved by the Engineer, mechanical mixers of an approved type shall be used for the mixing of mortar. Frozen, caked, or lumped materials shall not be used. Mechanical mixers, mixing boxes, and tools shall be cleaned after mixing each batch and kept free of mortar from previous mixes. Plaster mortar shall be thoroughly mixed with the proper amount of water until uniform in colour and consistency. Retempering will not be permitted and all mortar, which has begun to stiffen, shall be discarded. Mortar for scratch coats over metal lath shall be fibered by the addition of a pound of hair or fibre per bag of cement.

9.05 PROPORTIONING OF PLASTER

- a) All plaster shall be Portland cement plaster, all coats of which shall be mixed in the following proportions by volume or otherwise specified.
 One part cement
 4 parts sand
 1/4 part lime putty, if required or specified.
- b) All coats of plaster in liquid retaining structures shall be water proofed by the addition of an approved compound in liquid or solid form used at the approved rate. The water proofing compound shall be commercially pure with no grease or oils or other ingredients detrimental to the cement.

9.06 APPLICATION OF PLASTER:

- i) Strips of metal lath shall be provided between ceiling beams, lintels walls, columns and nearby partitions of masonry parallel to the beams if required. The lath shall be laced with the wire at joints between sheets and screwed to the concrete and masonry with galvanized offset head or hood head lath nails. Also lath not less than 3" wide shall be installed over joints between dissimilar base materials where the surface to be plastered by in the same plane and where the base materials cannot be effectively bonded or tied together.
- ii) Before the plaster work is commenced it shall be seen that all electric conduits, drainage and sanitary pipes inlets, outlets to tanks, brackets, clamps doors and windows frames and all sorts of inserts are fixed in position. It shall be the responsibility of the Contractor to bring to the notice of the Engineer if such work is not carried out by the other Contractors. Chiseling and repairing of cement plaster shall not be permitted under any circumstances.
- iii) The walls shall be washed with fresh water and shall be kept damp for 2 hours before the plaster is applied. All masonry joints and concrete surfaces shall be properly roughened before plaster work is commenced. The proportion of cement plaster shall be as per drawings or as specified. The ingredient shall be properly mixed. The sand used for mix shall be only sufficient for one bag of cement. The mixtures shall be turned over and over till the ingredients are thoroughly mixed. Cement slurry shall be applied to the surface to be plastered and allowed to dry before plaster work is commenced.
- iv) The plaster shall be from 1/2" to 3/4" thick and shall not be less than 1/2" thick at any surface. If the plaster is more than 3/4" thick it shall be done in two coats, the first coat shall be made rough. The plaster on all surfaces shall be perfectly in plumb. The edges and corners shall represent a straight line. The plaster shall be kept wet for at least 10 days. No extra payment shall be allowed for jambs, junctions, corners, edges, round surfaces, cement slurry base and for thicker plaster required due to any un-evenness in the work done by the Contractor. At edge of every horizontal projection on external faces of the building if directed by Engineer a drip course of 3/4" is to be provided for trickling of water without any extra cost. Plaster on lath shall be done in three coats. Finish coat shall have a reasonably uniform thickness of approximately 3 mm (1/8"), and the minimum thickness at any point shall not be less than 1.5 mm (1/16") and shall be applied in one continuous operation without staging breaks.

- a) The Scratch Coat: shall be full and thick and shall be applied with sufficient force to form good keys. The scratch coat shall be cross-scratched upon attaining its initial set and shall be kept damp with a fog spray.
- b) Brown Coat: shall be applied after the scratch coat has set, but not earlier than 24 hours after the application of the scratch coat. When applied directly to masonry, the brown coat similar to the scratch coat shall be applied with sufficient pressure to fill the raked-out joints in brickwork to prevent air pockets and secure a good bond. The brown coat shall be lightly scratched and broomed after attaining its initial set and shall be kept moist with a fog spray for 2 days and then be allowed to dry out.
- c) Finish Coat: shall not be applied until the brown coat has seasoned for 7 days. Just before the application of the finish coat, the brown coat shall be wetted evenly with a fog spray. All plaster shall be given a sand float finish of a uniform texture as approved or directed otherwise by the Engineer or his Representative. The finish coat shall be kept moist with a fog spray for at least 7 days and thereafter shall be protected against rapid drying until properly and thoroughly cured and dried.

9.07 **SAMPLING OF PLASTER**

Samples may be taken by the Engineer at any time from plaster work in place. Areas where over sanding is observed shall be rejected and shall have to be done again at the cost of contractor.

9.08 **DRIPS AND GROOVES:**

The Contractor shall make drips for rainwater protection and Architectural grooves shall also be made as shown on the drawings or directed by the Engineer.

9.09 **ALIGNMENT AND SMOOTHNESS**

All cement plaster shall be uniformly true in line level and plumb, smooth trowel finished, free of waves and blemishes etc; to the full satisfaction of the Engineer or his Representative.

9.10 **CLEANING AND PROTECTION**

Rubbish and debris shall be removed as necessary to make way for work of other trades and as directed by the Engineer or his representative.

As each room or space is completed all rubbish, debris, scaffolding and tools should be removed to leave the room clean.

Protect finished plaster from injury by any source.

Prior to plastering all Aluminium windows and finished metals should be covered by sheet of plastic or tarpaulin to protect it from damage.

Contractor shall also protect walls, floors and work of their trades from plaster materials.

9.13 **PAYMENT**

Plaster work will be measured and paid for the net area over which it is laid. All openings shall be deducted. The cost for drips and architectural grooves shall be included in the unit rate of plaster and no separate payment shall be made for drips and grooves.

SECTION - 10

10.0 **FLOORING**

10.01 **Scope of Work:**

The work covered under this section of the Specifications consists of furnishing all plant, labour, equipment, appliances and materials and in performing all operations in connection with the construction of floors complete as details of floors in strict accordance with this specification and the schedule of finishing, the applicable drawings and subject to the terms and conditions of the contract.

10.02 Before commencing any work under this section the Contractor shall study applicable drawings, schedule of finishing, details of floors, all levels etc. the Contractor shall also ascertain before starting of flooring that all pipes, trench etc. to pass under flooring have been placed in position and tested. Other concerned trades shall be consulted for completion of all required utilities prior to commencement of the work.

10.03 **Sub-Grade**

All sub-grade shall be prepared to the lines, levels and falls as indicated on the drawings, all subgrade should be compacted mechanically to obtain a density as specified. All sub-grade shall be inspected and approved by the Engineer before any subbase is placed on it.

10.04 **Material:**

i) Water

As specified in the relevant Section of the Specifications.

ii) Cement

a) The grey cement shall be ordinary normal setting cement of any brand complying in all respects with B.S. No.12.

b) White cement shall be complying in all respects with British Standard.

iii) Concreting:

All classes of concreting, "B", "C", "D" or "E" shall conform to their respective specifications as laid down in Section on "Concrete".

iv) Terrazzo Cast-in-Situ:

- a) The Contractor shall lay 1/2" thick terrazzo topping with white cement or grey as specified and use marble chips No.1 to 4 of approved colour and quality and shall have an abrasive hardness of not less than 16 as determined by the test of wear resistance in national bureau of Standard Report BMS-98. The various sizes of chips shall conform to following:

Chips size No.	Passing through Screen inches	Retained in Screen inches
1	1/4	1/8
2	3/8	1/4
3	2	3/8
4	5/8	1/2

Chips shall be crushed so that all the dimensions are close to the limits of the specified sizes. Flats or flaky chips shall be kept to a minimum. Colour of the chips shall be selected by the Engineer if the chips are not clean, the Engineer's Representative reserves the right to have them washed at the cost of the Contractor. Terrazzo topping shall be laid over concrete surface as given on the drawings and the ratio shall be 2 part of chips and one part of cement by volume.

b) **Division Strips**

Division strips shall be 1 1/2" wide strips of 5mm thick plate glass and will be suitably embedded and anchored. Division strips shall be fixed on the terrazzo in situ pavements on 4' x 4' grid, unless otherwise shown on the drawings or directed by the Engineer.

vi) **White/Black Glazed Tiles:** (Skid or non-skid)

6"x6"x1/4" or any other size as directed by the Engineer shall be best quality glazed tiles of manufacturer as approved by the Engineer.

10.05 **Method of Application:**

i) Terrazzo Cast-in-Situ:

The terrazzo shall be machine grinded to a true even surface using a No.24 grit followed by a No.80 grit or finer abrasive stone. After the first grinding, the floors shall be thoroughly grouted with the same cement and colour composition as specified for the matrix of the terrazzo mix. The grout shall be of the consistency of thick cream, and shall be brushed over the floor to eliminate all cavities and thoroughly fill the surface for final grinding. Not less than 72 hours after application, the grouting coat shall be removed by grinding. In the later stages of grinding the grit stones or other abrasive used in the grinding machine shall be of a grain or fineness that will give the surface a honed finish. Small areas, inaccessible portions and corners, which cannot be reached by the grinding machine, shall be ground and rubbed manually. After all grinding is completed the surface shall be polished to the entire satisfaction of Engineer or his Representative.

10.06 **Terrazzo Tile Flooring:**

a. General:

Terrazzo tiles of specified size and thickness made to the best local standard with best quality marble chips '0' to maximum of 3 No. size with white/grey cement and colour and pattern as approved by the Engineer on his Rep. shall be used for all floors except otherwise specified. Tiles shall be laid on a bed of cement-sand mortar of ratio not less than 1:6 and the mortar shall be covered with neat cement slurry and the joints of the tiles shall be kept perfectly tight and grouted with the cement of same colour as that of the matrix of the terrazzo tiles. Tiles shall be laid evenly and to the perfect level and shall be set between the walls of the room so as to cause minimum cutting of the full size tiles and where the tiles do not "Corner-out-even" the excess space area, joints pattern shall be continued throughout the floor.

Tiles shall be cured for a minimum of seven days after casting Terrazzo tiles shall be made of grey cement, white cement or a combination of two and to match sample for tiles available in the office of the Engineer. The joints shall not exceed 1/16 inch in any case and shall be rendered invisible as far as possible in colour with cement to match the tile colour. The joints shall be perfectly straight and shall meet perfectly with the lines of adjoining rooms. All terrazzo tiles shall be the product of reputable tile manufacturers and shall be cast and pressed hydraulically in machines especially made for the manufacture of Terrazzo tiles. The machines used and method of manufacture shall be subject to the approval of the Engineer or his Representative. The minimum thickness of Terrazzo Matrix on top shall not be less than 1/2 inch thick in any part of the tiles. Tiles with Terrazzo Matrix less than the thickness stated above shall be rejected and the Contractor shall have to replace the tiles at his own cost and risk. Contractor shall, before bringing the tiles ensure that these conform to the specifications with regard to their colour and size of Marble Chips. All rejected tiles shall be immediately removed by the Contractor from the site. All Terrazzo tiles shall be wax polished before acceptance.

- b) Chequerred Tiles:
Chequerred Terrazzo tiles for staircase and other specified locations shall be made to the same specifications as terrazzo tiles as specified in this Section. The exposed edges of Terrazzo tiles on steps shall have a Terrazzo Matrix on one edge of the tiles. The exposed edge shall project 1" from the finished face of the riser as shown on the drawing. Chequerred tiles shall be subject to the approval of the Engineer or his Representative. The tiles shall be 1" thick and the Terrazzo Matrix shall not be less than 1/2 inch.
- c) Polishing & Finishing:
Complete curing, initial grinding or cutting and finishing of the tiles shall be done prior to the delivery on the site. All Terrazzo floor tiles shall remain in place after setting for not less than 1 (one) week unless otherwise approved. Final grinding, cleaning and polishing shall be done to the best standard and upto the satisfaction of the Engineer or his Representative.
- d) Curing:
All Terrazzo floors and finishes shall be cured for a minimum of 7 days after laying by means of wet bags or sand or other approved methods.
- e) Defects in Tiles and Tile laying:
The surface of all tiled floors shall be perfectly as per level and grade as shown in drawings or as directed and shall be executed by experienced workers in the field of Tile laying. A sample Panel of laid Tiles of each type shall be got approved by the Engineer or his Representative before commencement of the laying. All chipped or damage tiles installed by the Contractor shall be rejected and shall have to be replaced by the Contractor at his own cost and risk.
- f) Wall Bases: (Skirting)
Wall bases where specified in all areas with Terrazzo shall be as shown on drawings. All wall bases shall be made with cast-in-situ Terrazzo and the colour and size of marble chips used shall be such as to match with the terrazzo tile floors in each room or area. The minimum thickness of Terrazzo Matrix shall not be less than 1/2" thick. The height of wall bases shall be as shown on the finish schedule and the relevant drawings. The surface shall be perfectly smooth and polished to a high degree of finish. The top edge of wall base shall be perfectly straight. Sample of each type of wall bases shall have to be approved by the Engineer or his Representative before commencement of work of wall bases by the Contractor. All applicable Specifications pertaining to Terrazzo cast-in-situ as laid in this Section shall be applicable for cast-in-situ wall bases. All tiles shall be laid before the work of wall bases is started and no cast-in-situ Terrazzo of wall bases shall be allowed on the flooring to overcome defect in tile laying.

10.07 Glazed Ceramic Tiles:

Glazed tiles will be of size 6 inch x 6 inch or as directed by the Engineer and of best quality of local manufacturer white/colored shall be supplied by the Contractor. All sanitary and water supply pipes shall be in place before start of glazed tiles work.

The walls and floors on which the glazed tiles are required to be fixed shall be plastered with 1:4 cement mortar 1/2"-3/4" thick as base for the tiles and surface shall be thoroughly roughened. Before starting to fix the tiles the plaster shall be thoroughly wetted and cement slurry spread on the surface. Neat cement mixed with water in the form of thick paste shall be uniformly applied on the tiles-back and the tiles pressed on the wall so as to spread the cement paste uniformly under the tiles. The squeezed out slurry shall be wiped out of the edges. The tiles shall be laid course after course starting from bottom. No joint shall be more than 1/16" and all joints shall be uniform and continuous. The slurry shall be gently raked out from the joints when it is green. White or coloured cement of the same shade as tiles shall be applied in the raked out joint and finished slightly sunk with the tiles surfaces.

10.08 Marble Tiles in Flooring, Skirting, Dado and Steps

- a. Material
Marble for use on the building shall be selected first quality marbles of type and colour as specified by the Engineer or his Representative marble shall be the best quality China Verona marble free from discolorations. Anchors and Cramps shall be made of non-ferrous metal as detailed on the drawings and specified and directed. Cement shall be white Portland cement meeting with the requisite British Standard Specifications. Coloured marble shall be other than dark Green onyx marble. Green Onyx: Where specified best quality of dark green marble shall be used meeting with the approval of the Engineer.
- b. Samples:
Samples of all types of marble for various areas shall be got approved by the Engineer or his Representative. Contractor shall have to match the marble brought to site as close to the approved samples as possible. The Engineer or his Representative has the right to reject marble pieces, which have unduly dark patches, or large unsightly veins which do not conform to the overall pattern and effect on the marble wall. Contractor shall also construct a Panel for each of the marble areas for the approval of the Engineer or his Representative before commencement of work. Engineer's discretion with regard to quality of marble shall be final and binding on the contractor.
- c. Workmanship:
The size of marble slabs and the jointing pattern shall be as shown on the drawings or as directed by the Engineer or his Representative. Joints between the marble slabs shall be filled smooth with white cement paste of the

required shade of the marble slabs. The marble slabs before being laid shall be machine cut, dressed smooth and mirror polished and shall be free from cracks or any other discolorations, which in the opinion of the Engineer or his Representative is objectionable. All such defective and rejected marble slabs shall have to be replaced by the Contractor at his own cost and risk. The thickness of marble slabs shall be as specified.

d. Selection of Marble:

The marble slabs shall be selected by the Contractor in the factory before these are brought to site for installation purposes which match the samples in the office of the Engineer. Marble pieces which do not meet with the approval of the Engineer or his Representative shall be removed and replaced by the Contractor at his own cost and risk, whether they have been installed or not.

e. Installation:

Marble for floors, walls, shall be laid on a bed of mortar by workmen specialized in the marble work. All floors shall be perfectly level and joints rigidly conforming to the joint pattern. Any leveling of concrete floor or filling in of low spots by mortar for levelling shall be done by the Contractor at no extra cost to the owner. Wherever slope for drainage purposes is required the bed shall be pitched to slope. Marble slabs in walls and columns shall be properly anchored to the wall or column as well as between the slabs themselves by means of anchors and cramps as detailed on the drawings or as directed. Non-ferrous metal anchors and cramps shall be used. Anchors shall be rigidly bolted to the wall.

f. Even Panels:

In each surface marble panels both horizontally and vertically shall be so divided that the sizes of all panels are equal. The surface of panels in the pattern shown on drawings may be adjusted in each room with the approval of the Engineer or his Representative in order to have all equal sized panels of marble.

Before cutting the marble pieces for each space the Contractor shall take actual physical measurements of the constructed portion so that even sized marble panels can be fitted at all places. Unequal panel sizes shall not be acceptable and shall be replaced at the cost of the Contractor. Joints between marble panels shall not be more than 1/16" and shall be filled in with white cement slurry as specified.

g. Kitchen Cabinet Tops:

Specially selected marble slab shall be used for counter tops as specified and directed. These marble slabs shall first be approved by the Engineer or his Representative before actual cutting and installation of marble slabs is undertaken. Counter tops upto 3'-0" length shall be one piece marble slabs and for over 3'-0" long counters two marble pieces shall be used to obtain the required length of the counter. The cutting of holes in slab for sink and water taps where required shall be accurately done according to the actual size of sink and piping. The Contractor shall coordinate this work with the sanitary contractor. Marble slabs wherever indicated to be installed shall be mirror polished and finished before installation duly cut to the required size.

h. Finishing and Polishing:

All marble before being laid in the final position shall be finished and polished to a high degree of mirror finish by means of machine grinders in the factory. Where machine grinders cannot be used grinding and polishing by hand may be permitted by the Engineer or his Representative. All polished surfaces shall meet the approval of the Engineer or his Representative before acceptance.

10.08 **Cement Concrete Flooring:**

The materials for C.C. flooring shall be the same as already specified under other clauses of these specifications.

a. Composition of Concrete

Concrete shall be composed of Portland cement, sand, coarse aggregate and water, all well mixed and brought to the proper consistency. The Contractor shall mix the ingredients as shown on the drawings or as specified. The proportions of the various ingredients shall be determined from time to time during the progress of the work and tests shall be made of samples of the aggregates and the resulting concrete. The mix proportions and appropriate water cement ratio shall be determined on the basis of the production of concrete having required workability, density, impermeability, durability and required strength.

b. Mixing Concrete

The concrete ingredients shall be mixed in batch mixer for not less than 1 1/2 minutes after all ingredients, except the full amount of water, are in the mixer. The Engineer reserves the right to increase the mixing time when the charging and mixing operations fail to produce a concrete batch in which the ingredients are not uniformly distributed and the consistency is not uniform. The concrete shall be uniform in composition or consistency from batch to batch except when changes in composition or consistency are required. Water shall be added prior to, during and following the mixer charging operations. Excessive over-mixing requiring the addition of water to preserve the required concrete consistency shall not be permitted. The concrete ingredients shall be mixed by volume in boxes made for this purpose and approved by the Engineer.

c. Construction

The base course of the floor shall comprise of stone in case of Car park garages and road pavement. The base course shall be thoroughly compacted by suitable power rammers to the total consolidated thickness as shown on the drawings and as approved by the Engineer. The interstices shall be filled with smaller size stones screened material with finer particles. The base course shall be blinded with sand and the whole surface watered. Over the well compacted base course, a layer of 1:2:4 concrete of the required class and thickness shall be laid in panels of the sizes as indicated on the drawings and as approved by the Engineer.

At places other than mentioned above, base course of required thickness and class of concrete shall be laid over a sub-grade compacted to 95% AASHTO density.

After the C.C. bed has been cured, as directed by the Engineer, it shall be roughened and well watered before floor finishing is laid. The floor finish shall comprise of cement concrete 1:2:4 nominal mix or of such proportion as specified or directed by the Engineer and of the required thickness shall be laid in alternate panels with butt joints to the required thickness as shown on the drawings and/or as directed by the Engineer. The concrete after lying will be thoroughly rammed and mortar worked up to the top and smoothed with a steel trowel. The edge of each section into which the floor is divided should be defined by wooden screeds of the approved width and of a depth equal to the depth of floor concrete.

Freshly placed concrete floor portions as finished shall be protected to prevent loss of water by covering with damp hessian, waterproof paper, or other approved material, and shall be kept constantly damp for a period of 10 days or longer after concreting, as directed by the Engineer. The concrete shall be allowed to dry out slowly over a period of a few days after wet curing is completed.

10.09 LVT

Luxury Vinyl Tiles shall be layered according to the Specification given by the Manufacturer. A part of that shall be first layered and inspected by the consultant prior to commencement of the work. All safety and security measures shall be taken into account.

10.10 Impact Protection Floor

Rubberized Impact Protection floor shall be layered according to the Specification given by the Manufacturer. A part of that shall be first layered and inspected by the consultant prior to commencement of the work. All safety and security measures shall be taken into account.

10.11 Artificial Grass

Artificial Grass tiles shall be layered according to the Specification given by the Manufacturer. A part of that shall be first layered and inspected by the consultant prior to commencement of the work. All safety and security measures shall be taken into account.

10.09 Measurement and Payment:

All the items of work covered by this Section of the Specifications shall be measured by the Standard Method of measurements. The quantity of flooring will be ascertained by measuring length and breadth of actual area laid deducting any section of columns and other structures penetrating throughout the floor and shall be paid for at the individual item rates entered in the Bill of Quantities and in accordance with the applicable terms and conditions of the Contract.

SECTION - 11

11.0 WOODEN DOORS AND WINDOWS

11.01 Scope:

The work covered by this section of the Specifications consists of furnishing all plant, labour, equipment, appliances, and materials, and in performing all operations in connection with the provision and installation of all doors, windows shutters and frames complete in all respects in strict accordance with this section of the Specifications and the applicable drawings, and subject to the terms and conditions of the Contract.

11.02 Materials:

Material for the work included herein shall conform to the following requirements: -

Samples of the following materials

Shall be delivered to the Engineer for testing and approval before delivery of these materials to the site:

- Corner section of each type of door.
- A Panel of each kind of wood.
- A Section of hollow metal steel door frame, if specified.

11.03 Grounds, Blocking and Nailing Strips:

Grounds, blocking, and nailing strips shall be provided as necessary to receive the work included herein and as required for the work of other trades:

- a) Except as otherwise shown or specified, ground, blocking and nailing strips shall be secured in place as follows: -
- 1) To steel - by means of 3/8 inch diameter bolts spaced not over three (3) feet apart.
 - 2) To brick - by use of cut nails spaced not more than 16 inches apart.
 - 3) To concrete blocks - by the use of cut nails spaced not more than 16 inches apart and driven directly into the block.
 - 4) To poured concrete - by means of 1/4 inch diameter galvanized expansion bolts spaced not more than 16 inches apart or by the use of Rawl Plugs one (1) inch long and galvanized at the same spacing.

11.04 Metal Door Frames (Other Than Aluminium Doors):

11.4.1 Specifications & Standards

The following British and American Standard specifications applicable are relevant and applicable for this section:

BS-1245	Metal Door frames (Steel)
BS-2994	Specification for cold rolled steel sections
ASTM -	B117
ASTM -	1735

11.4.2 Samples

Contractor shall submit complete sample of Door Frames showing joint, construction and hardware and hinges etc. along with manufacturer's catalogue and literature for approval of the Engineer.

11.4.3 **Manufacturers**

- A. Door frames shall be manufactured by reputable steel hollow metal fabricators approved by Engineer.
- B. Frames shall conform to British Standard Specification 1245 or equal.

11.4.4 **Hollow Metal Steel Door Frames**

- A. Door shall be of 18 gauge mild steel sheets and frame made of suitable sections as specified, to exact profiles with prime coat of grey colour and 3 coats of enamel paint.
Except as otherwise indicated, corners of frames shall be welded together and rounded.

Door frames shall be provided with steel sheet reinforcement for all hardware including door checks and closers. Reinforcement plates shall be at least as thick as diameter of screws used for securing hardware.

Frames shall rest on concrete slabs floor have temporary bottom spreader bars and be secured with concealed clip-angles and wall anchors.

B. Frame Anchors:

Doors frames shall have not less than three (3) tee wall anchors and one (1) clip-angle type floor anchor per jamb as per manufacturer's recommendation.

Wall anchors shall be adjustable welded tee or strap anchors, of 8 inches length for masonry constructions.

Wall anchors at construction other than masonry as indicated shall be of special design for anchoring to column & R.C.C. walls meeting with approval of the Engineer.

11.4.5 **Installation**

- A. All work shall be accurately set to established lines and rigidly fastened to the constructions. Frames shall be erected plumb and true and shall be braced during construction and until there is no danger of movement.
- B. In masonry walls, anchors shall be built-in during progress of brick masonry work. Space between backs of frames and masonry shall be grouted full of c.c. mortar (1:4) with anchors securely bedded in mortar joint.
- C. Frames shall be accurately fabricated, assembled and fitted and shall be free from defects affecting appearance and proper operation. Steel reinforcing channels where required shall be provided in each frame.
- D. Two PVC stoppers 1/4" dia to prevent door shutter striking metal frame shall be provided in each frame.
- E. Three hinges 5" long in each frame shall be provided.

11.05 **Wooden Door Frames**

The door frames shall be of Deodar wood. The timber selected for manufacture shall be of good quality, free from all defects and well seasoned. The frames shall be of the specified size and section and shall be finished smooth. The frames shall be secured perfectly in level and plumb and corners shall be perfectly at right angles.

The frames shall be provided with 6 flat MS holdfasts. The size of holdfasts shall be as specified or directed by the Engineer. The ends of holdfasts shall split and bent. Holdfasts shall be fixed to the door frames with proper size screws and shall be embedded in cement concrete class "C" for the full length of the holdfasts and the width of the wall. The holdfasts shall be cleaned to remove any dust-scale or rust etc., and shall be painted with two coats of red oxide paint.

11.06 **Interior Wood Doors:**

Interior wood doors shall, unless otherwise shown or specified, be of the paneled type or flush as indicated on the drawings or directed by the Engineer.

Paneled doors shall be constructed in accordance with the requirements part 1 of British Standard Specification No.459, with the additional requirements that panels in exterior openings shall be assembled with waterproof glue. Loose beads shall be provided in glazed wooden doors for holding glass panes of thickness and size as specified and shown in drawings or directed by the Engineer. Ends of louvers blades shall be let into edges of door stiles and glued and tacked in place. Flush doors shall be constructed in accordance with the requirements of British Standard 459.

11.07 **Closet Doors:**

Closet doors shall be 1-1/2 inches thick, unless otherwise shown and shall be either paneled or flush. If paneled they shall comply with the requirements of part 1 of British Standard Specification No.459 and if flush, they shall comply with the requirements as called for on the drawings.

11.08 **Doors Shutters:**

The shutters will be fixed to the frames with approved quality brass fittings. The frames will be secured with wrought iron clamps, or screwed pre-embedded and wooden pegs, bent and screwed to the frames at one end, cut and built into the brick work or block work on the other end or as directed:

- a) All doors and windows shutters shall be fabricated in a workmanlike manner in accordance with the drawings or as directed by the Engineer or his authorized representative.
- b) The door shutters to have solid core as shown on the drawings. It shall be built in sections properly jointed and glued together, both sides being covered with 3 mm thick plywood or as specified veneering and prepared for painting as specified.
- c) The arrangements of inner core for semi-solid shutters shall be approved by the Engineer or his authorized representative. It shall be so adjusted that circulation of air is free and uninterrupted and minute holes to admit and exit atmospheric air, shall be provided on edges at suitable places.

- d) The two long edges of the shutters to be tipped with a solid sheesham lipping piece, not less than 1/2" being exposed, double tongued and grooved into the core, the plywood to meet the lipping piece by means of mitred joints.
- e) Each door shall be suitable to receive hinges and locks in the position shown.
- f) The rates shall include supplying fittings and screw nails etc. and hanging with hinges, clear or obscure glass of thickness as specified and painting etc. complete.

11.09 Fitting, Hanging, and Trimming:

Doors shall be fitted, hung, and trimmed as hereinafter specified and as indicated on the drawings. Doors shall have 1/16 inch clearance on side and top, unless otherwise directed by the Engineer-in-Charge and shall have 1/8 inch clearance at bottom. Doors 1 3/4 inches or more in thickness shall have the lock or latch edge beveled at the rate of 1/8 inch in 2 inches. Doors shall be hung and trimmed with hardware as specified. Locks with standardized cases shall all be installed at the same height. Knob locks and knob latches shall be located at height as directed by the Engineer. Dead locks shall have the centre of the locks at the same height as the centre of the knob locks.

11.10 Hardware:

Items of hardware specified herein shall be carefully fitted and securely attached and upon completion of the work got approved by Engineer or his Representative. Hardware shall be demonstrated to work freely, keys shall be fitted into their respective locks and, upon acceptance of the work, keys shall be tagged and delivered to the Engineer who will furnish a receipt.

11.11 Measurement and Payment:

- a. All wooden doors frames, finishing and hardware as specified hereinbefore as well as painting shall be paid for the rates entered in the Bill of Quantities appended to the contract and in accordance with the conditions of the contract.
- b. All wooden doors Shutters, finishing and hardware as specified hereinbefore as well as painting shall be paid for the rates entered in the Bill of Quantities appended to the contract and in accordance with the conditions of the contract.
- c. All wooden doors Architrave, finishing and hardware as specified hereinbefore as well as painting shall be paid for the rates entered in the Bill of Quantities appended to the contract and in accordance with the conditions of the contract.

SECTION - 12

12.0 TIMBER JOINERY AND HARDWARE

12.01 Scope of Work:

The work covered by this section of the Specifications consists of furnishing all plant, labour, equipment, appliances and materials and in performing all operations in connection with fabrication and installation of shelves, cupboards, paneling, doors, frames, shutters etc. as per size, thickness, dimension and details shown on the working drawings, complete in strict accordance with this section of the Specifications and the applicable drawings, finishing schedule, instructions of the Engineer and subject to the terms and conditions of the Contract.

12.02 Materials, Fittings and Samples:

i) Timber etc:

The entire timber conforming to BS No.881/589:1955 shall be from the heart of sound and full grown trees, it shall be uniform in substances, properly seasoned, straight in fibre, free from large loose or dead knots, twists, cracks, incipient decay. The scantlings of all timber shall be bright sound and square edged. The colour of the timber shall be uniform throughout. The timber shall be tested before use to ensure that the moisture content where allowed shall not exceed 10%. The Contractor shall pay for such tests. All timber before use shall be subject to the approval of the Engineer.

a) Soft Wood:

The timber of trees belonging to the botanical group Gymnosperms, commercial timber deodar of this group, with best of its kind available in Pakistan shall be used.

b) Hard Wood:

The timber of trees belonging to botanical group Angiosperms, commercial timber teak of the group shall be used.

c) Plywood:

Shall comply in all respects with BSS 1455:1948. The plywood shall only be obtained for doors; paneling and the like shall be of the thickness as specified. The grade shall be first quality. The face and back shall be free from end joints, dead knots, overlaps, patches and other defects. Edge joints in Veneers shall be well made. Isolated pin-worm holes shall be permitted provided they do not run along the plane of the veneer. The face and back shall be finished smooth for painting or polishing.

d) Formica and Chip-board:

Shall be first class quality of its kind in Pakistan from manufacturer approved by the Engineer.

e) Veneers:

Of selected quality shall be used. The veneers shall be carefully selected so that the grains shall be matching and running in the same direction. The cross banding shall not be less than 1/16 inch and the combined thickness of cross banding and face veneer on each door shall not be less than 1/8 inch. The

cross banding and face veneer shall be teak wood or as indicated. The face veneers shall be uniform texture and glued to core as specified hereinafter.

ii) **Hardware and Fittings:**

Hardware and fittings shall be heavy duty hardware of approved quality and manufacturer.

- a) Locks and Door Closer: shall be foreign make and as approved by the Engineer.
- b) Glue: shall conform to the requirement of BS.745 for cake or powder glue.
- c) Nails and Screws: Nails shall comply with requirements of BS.1202 and screws with the requirements of BS.1210.
- d) Holdfasts: shall be M.S. flat iron 1-1/2" x 1/4" and of length as specified in the drawings, or shall be as directed by the Engineer.
- e) Tower Bolt: shall be chromium plated brass of approved quality.
- f) Hinges: As specified on drawings or 4" size Heavy duty, brass screws (local) of approved quality to be used.
- g) All other fittings shall be best available foreign made or local as specified. Samples shall be submitted to the Engineer with for his approval. Cost of all hardware shall be included in the prices quoted by the Contractor in B.O.Q. for doors, windows, cabinets and cupboards etc. and no separate payment will be made.
- h) Hardware Schedule: Each flush shutter door and closet door shall be furnished to the extent not otherwise given in the item of work or shown on the drawings with the following:-
 - i) 4" brass butt full mortise hinges-3 pairs
 - ii) Mortise lock with knobs as above 1 No.
 - iii) Chromium plated brass made in one piece tower bolts 10" long of local manufacturer 2 Nos. for single leaf door and three 10" long tower bolt for two leaf door.
 - iv) Stainless steel push plates and kick plates.
Each closet door shall be fitted with the same hardware as described above for single shutter doors with the exception that instead of cylinder mortise lock they will have a Union night lock or approved equal with a stainless knob of local manufacture.
 - v) Best available door closer of approved size and design shall be provided as per drawing and as approved by the Engineer.
 - vi) All the locks shall be master keyed and a ground master key shall be furnished for all the locks.
 - vii) Suitable hold fasts as approved by the Engineer.

12.03 **Flush Doors:**

Flush Door shall be solid cored, covered on both side with commercial ply as specified in drawing. The doors shall be lipped and edges fitted and hung to the frames. The flush door shall be as obtainable from M/S Dawn or its equal approved by the Engineer and shall be of best quality and uniform texture.

12.04 **Handrails Wooden:**

Wooden handrail for staircase as shown on drawings or as directed shall be made of straight grain Deodar, accurately machined to detail and shop finished as specified. Rails shall be manufactured from stock requiring minimum of joints. Necessary joints shall be put together with at least two(2) hardwood dowels. Wooden handrail shall be provided on M.S. balustrades, the same being fixed with steel plates in the steps complete as shown in the drawings or as directed by the Engineer.

12.05 **Cupboards/Ward Robes**

These shall be of commercial ply shutters fixed on deodar wood frames all of sizes as shown on drawings and as directed and approved by the Engineer and shall include R.C.C. slab at top, both sides plastered and cement concrete base with plaster. Position and type of portions, shelves, drawer and brass pipe (1" dia) for hanging of clothes etc. shall all be provided as per drawing, directions and approval of the Engineer, complete in all respects with required hardware and painting inside and outside.

12.06 **Cabinets**

a) Low Level Cabinets

These shall have R.C.C. slab at top finished with marble slabs, concrete base at bottom and R.C.C. shelf in the cabinet. The R.C.C. slab, shelf and the base shall all be finished with cement plaster, cabinets shall have drawers and commercial ply shutters fixed on deodar wood frames.

b) High Level Cabinets

These shall also be made of commercial ply shutters fixed on deodar wood frames. The shelf in the cabinet, its top, bottom and sides shall all be of commercial ply fixed on deodar wood frames as shown in drawings.

Both the above cabinets shall be as per drawings, instructions and approval of the Engineer and shall be complete with all the required hardware and painting etc.

12.07 **Counter**

Counter shall be made of 1:2:4 R.C.C. slab at top resting on R.C.C. wall of thickness as shown in drawing and both finished with cement plaster on the inner faces. Marble slabs on top, sides (with grooves) and base of the counter shall be provided of size and thickness as per drawing and approval of the Engineer. Teak wood shelf of 1" thickness shall be

provided inside the corner as shown in the drawing. The job of providing counter shall be complete in all respects including painting of shelf and finishing and polishing of marble etc.

12.08 Fabrication:

- a) The Contractor shall perform all necessary morticeing, tenoning, grooving, nothing, tonguening, housing, rebating and all other work necessary for the correct jointing. The Contractor shall also provide all metal plates screws, nails and other fixing that may be necessary or instructed by the Engineer for the proper execution of the joinery work specified. The Contractor shall also be required to carry out all works necessary for the proper construction of all framings, etc. and for the support and fixing in the building. All wood work shall be approved by the Engineer or his Representative before being fixed in position.
- b) Any Joinery which may show signs of defects arising from the unsound materials or defective workmanship before the expiry of the maintenance period shall be cut out and replaced at Contractor's own expense.
- c) All hold-fasts are to be cut to size and shall be made of 1/4" thick M.S. flat iron as shown on the drawing.
- d) Until and unless shown or directed otherwise all external frames joinery work including doors and windows frames shall be put together with a thick mixture of white lead and pure linseed oil and the joints shall be provided with hard wood pins.
- e) All doors, shutters shall be fabricated in workmanlike manner in accordance with the drawings or as directed by the Engineer.
- f) The doors shutters shall be solid or paneled as shown on the drawings or specified or as directed by Engineer. It shall be built in sections properly pointed and glued, and painted as specified.
- g) Each door shall be suitable to receive hinges and locks in the position shown.
- h) The rates shall include supplying all fittings and screws, nails and such like and hanging hinges clear or obscure glass of thickness as specified and polishing or painting etc., complete including lock, and other fittings, except door closer which if required shall be separately paid.
- i) Brass fittings are to be furnished and oxidized on exposed surfaces. Aluminium fittings are to be anodized on exposed surfaces. Chromium plated fitting are to be the best quality of their respective kind made locally and shall have a base of brass or copper.
- j) Brass oxidized fittings are to be fixed with brass screws, copper gunmetal or bronze .op
- k) Locks, handles, etc, shall be as directed and approved by the Engineer or his authorized representative.
- l) The whole of the iron, brass oxidized fitting must be of the best possible quality and workmanship. The Contractor shall submit samples for the approval of the Engineer and all such iron, brass and bronze mongery shall conform to these approved samples.
- m) Glazing wherever shown on drawings or given in B.O.Q. shall be best available glass of specification as described under glass and glazing.
- n) Paint and polish shall be carried out as specified in specification for Painting and Polishing.
- o) Anti-termite treatment of approved quality shall be applied to frames on the surface in contact with earth, or wall etc. as per directions of Engineer. Contractor's rates in BOQ for doors, Ventilators windows, shelves etc, shall include this item and no additional payment shall be made.
- p) 3 coats of approved quality enamel paint over a coat of oxide or approved quality wax or French polish shall be applied to the doors, windows etc. as per directions of the Engineer or as described in B.O.Q. or in drawings. No additional payment shall be made against this item and the Contractor's rates for joinery work shall include cost of this item.
- q) Formica facing over chip-board sheets it required, shall be done with appropriate adhesion and pressure to ensure proper joints.

12.09 Measurement and Payment:

The items of work acceptably fabricated, installed and executed as per this section shall be measured and paid for as under:

- i) Wooden hand rail shall be measured in running feet length of the hand rail fixed in position including M.S. balustrades, steel plates, fixing in position and painting etc. complete in all respects and shall be paid at the rate entered in BOQ.
- ii) Cupboards and Kitchen Cabinets acceptably completed in all respects shall be measured and paid in square feet of the front shutter area at the rate quoted in the BOQ.
- iii) The payment for the reception counter shall be made on lump sum as a complete job.

SECTION - 13

13.0 ALUMINIUM ANODIZED DOORS, WINDOWS AND VENTILATORS

13.1 SCOPE:

The work covered by this section consists of furnishing all labour, equipment, supplies and materials and in performing all operations in connection with the fabrication, construction and installation of anodized aluminium doors, windows and ventilators complete with all glazing fittings and fixtures in strict accordance with this section of the specifications, and the applicable drawings and subject to terms and conditions of the Contract.

- 13.2 Aluminium anodized doors, windows and ventilators where required are to be in sizes and pattern as shown on the drawings having a single glass pane contained in aluminium frames which in turn are contained within an aluminium frame designed so that one or more panels are moveable by sliding in windows and swing in doors in horizontal direction. The panels may also be fixed on top hung and swing, all as shown on drawings.
- 13.3 The Contractor shall submit shop drawings for all the doors windows, and ventilators to the Engineer and the fabrication shall be taken in hand only after his approval of such drawings. All the doors, windows and ventilators shall be manufactured by a reputable firm having an experience of not less than ten years in the line subject to the approval of the Engineer.
- 13.4 **DEFINITION:**
The definition given in BS-2900, BS-4643 and BS-3958 apply generally but, in addition, for the purpose of this specification the following definitions apply:-
Pivoted Hinges: An arrangement to properly swing the shutters of doors and windows where required with brass pivots provided at top and bottom with a thrust bearing at bottom for friction free operation.
Bearing Device: A suitable wheel or roller device to support the weight of a moving panel.
Glazing Gasket: PVC or synthetic rubber member, used between the glass and the frame and/or glass and a bead.
Hardware: Fittings attached to the door, window and ventilators which are used to operate and/or secure it.
Outer Frame: The metal frame which is fixed to the building structure or the door, window or ventilators surround and which contain the shutters and panels.
Panel: Movable or fixed glazed frame.
Stile: Vertical member of a panel or shutter.
Weather Stripping: A PVC or synthetic rubber material to improve resistance of the closed window, door and ventilator to air infiltration and water penetration.
- 13.5 **MATERIAL:**
Aluminum: Extruded aluminum members shall be fabricated from designated treated alloys HE 9 TF, HE 9 TE, HE 9 TB, or HE 30 TF complying with the requirement of BS-1474. When ancillary members are formed from sheet materials, they shall be fabricated from designated alloys SIC, NS3 or NS4 complying with the requirements of BS-1470 in a temper suitable for the particular type of framing to be adopted.
The main elements of aluminium solid (not hollow) section outer frame shall be, at minimum tolerance, not less than 1/16" thick. Finishes to aluminium shall be anodized and comply with the requirements of BS-3987.
Weather Stripping: Weather stripping shall be made from materials known not to react with aluminium and such that any shrinking warping or adhesion to sliding, swinging or closing surfaces shall not impair the performance of the doors, windows or ventilators.
Glass: Glass shall be of the best quality available as per Pakistan BS-952 Glass thickness shall be according to British Standard CP-152 (Section 3.8) and anti shutter fitted shall not be less than 6 mm for doors and 6 mm plain clear or translucent for windows and ventilators or as per drawings.
Joint Sealing Materials: Joint sealing materials shall not harm adjacent material or finishes.
- 13.6 **CONSTRUCTION:**
In the case of doors, windows and ventilators not fully assembled and glazed by the manufacturer, the manufacturer shall provide instructions as to the manner of assembly.
Adjacent aluminium members shall not slide upon each other but shall be separated by a material that does not react with aluminium, and does not interfere unduly with the sliding or swinging.
The moving window panels shall be supported by bearing devices that facilitate the movement and prevent direct contact between the panels and the tracks.
The doors, windows and ventilators shall be capable of adjustment to assure proper fitness and operation.
The finished doors, windows and ventilators shall be free from all sharp edges, burrs and the like that might be hazard to the user.
It shall not be possible for a panel to become accidentally disengaged from the outer frame.
On all finished doors, windows and ventilators means shall be provided to prevent injury to the users' hands where the hand grip may meet or pass close to another panel during operation.
Joints in frames shall be made either by welding or by mechanical means (example are cleating and screwing). Where necessary, joints shall be sealed with material that does not react with aluminium. Joints may have flush, stepped or lapped surfaces. Flush joints, formed by mechanical means may deviate from the same plane only within the limits set by the use of extrusion tolerance given in BS-1474. Welded joints shall be cleaned off smooth on surfaces visible when the doors windows and ventilators are open or closed and where they might interfere with glazing.
- 13.7 **HARDWARE:**
Hardware, including its fastenings, shall be of suitable materials resistant to atmospheric corrosion. If such materials or finishes used react adversely with aluminium they shall be separated from the aluminium by materials that do not react adversely with it.
- 13.8 **FASTENING AND FIXINGS:**
All screws, nuts, bolts, rivets, washers, other fastenings, used in assembly and fixing devices shall be of stainless steel or aluminium. Alternatively where these are permanently concealed they may be made from steel which has been finished by one of the following methods:-

- i) Zinc plated and passivated accordingly to B.S. 1706 clarification Zn3.
- ii) Hot-dip galvanized according to the requirements of BS.729.
- iii) Sheradized according to the requirements of BS.729 part-2 (not applicable to fixing devices).
- iv) Sprayed with metal coating according to BS. 2569, Part I. The fixing shall be capable of withstanding the design of the doors, windows and ventilators.

13.9 The limits of sizes for overall length and overall height may be as stated by the manufacturer, taking into account permissible deviations in sizes and squareness, but shall not be more than 1/12" on the overall lengths and heights.

13.10 **GLAZING:**

The glass shall be as specified in the relevant section and shall be framed on all four sides.

Glazing beads, gaskets, glass adopters and glazing compounds shall be of materials that do not react with aluminium finishes, glass or other glazing material.

Glazing beads and other members shall be stiff enough and fixed at a sufficient number of points to with-stand the design wind loading and to ensure safety in use.

The consideration shall be such that glazing or reglazing on site is possible without the need to remove the outer frame of unit from the buildings.

13.11 **SECURITY:**

Locking devices where required shall be designed so that they cannot be released from the outside by the insertion of a thin blade or other simple tool.

Normally, and unless otherwise directed by the Engineer, no door, window or ventilators panel shall be open-able or removable from the outside when it is locked in the closed position except by the use of special tools or by breaking a part of the door, window or ventilator.

Where directed by the Engineer locks may be key operated from the outside or inside and supplied with removable keys.

13.12 **PERFORMANCE:**

Doors, windows and ventilators shall be backed with a performance guarantee free from any trouble for a period of at least ten years commencing after the expiry of period of maintenance.

13.13 **SHOP DRAWINGS:**

Contractor shall submit, to the Engineer shop drawings showing details of construction and assembly of the windows and the fabrication of doors, windows and ventilators shall not be started until the drawings have been approved.

13.14 **SAMPLES:**

A sample of each type of door, window and ventilator complete with hardware, accessories and other items, whether or not requested by the Engineer shall be submitted for his approval, marked with identification tags.

13.15 **MEASUREMENT AND PAYMENT:**

The doors, windows, and ventilators shall be measured nett between the outer edges of the aluminium frames and paid for at the unit rates entered in the Bill of Quantities, appended hereto, and in accordance with the Conditions of the contract. Unit rates for doors, windows and ventilators shall be inclusive of all anodizing, glazing and fly proof shutter with mesh etc., complete as specified.

SECTION - 14

14.0 **FALSE CEILING**

14.1 **SCOPE OF WORK:**

The works covered by this section of the specification consist of furnishing all plant, labor, equipment and materials and in performing all operation in connection with provision and installation of the False ceiling and related works, wherever required as per drawings, specification and as directed by the Engineer.

14.2 **GENERAL:**

Acoustical ceiling work shall be installed wherever indicated on the drawings or instructed by the Engineer. Shop drawings showing the mechanical suspension system, disposition of ceiling units to present form or pattern as approved and also showing the required grooving wherever required, details of molding at wall junctions at the periphery and other details shall be prepared by the Contractor within the rate of the item of the agreement the contractor shall get the shop drawings approved by the Engineer before undertaken this item of work.

14.3 **MATERIALS:**

a. Hangers:

The Hangers shall be of MS Flats as per standard suspenders supplied for Acoustic ceiling. All hangers, if not factory painted shall be painted with one coat of red lead paint and two coats of approved quality enamel paint. It is the responsibility of the Contractor to get the sample of hanger approved by the Engineer before using the same in the works.

b. Suspension Frames

These shall be the standard frames as provided by the manufactures for Acoustic ceiling with perforated aluminum units. Surface stove enameled and including mineral wool infill and glued black tissue paper inlay. Access panels and light fitting recesses shall be provided as required at site.

c. Acoustic Tiles of approved size manufactured from Boral Plastic Board gypsum board.

14.4 **INSTALLATION AND WORKMANSHIP**

Suspension System

The hanger as specified shall be evenly placed in position as indicated in drawing details, at the time of concreting of RCC roof and beams. Their lengths shall be properly adjusted to maintain the horizontal surface of the false ceiling. Wooden framing shall be nailed to these hangers for fixing acoustical tiles and light fixture over it. The jointing of Deodar wood battens to hangers shall be as per approved shop-drawing details. Acoustical tiles shall be a sound absorption co-efficient of 0.67 at 500 cycles per second (CPS).

14.5 **FINISHING**

After installation, dirty, soiled or discolored surface shall be cleaned up left free from defects and ready to receive any painted finishes, if required.

14.6 **MEASUREMENT AND PAYMENT**

Unless otherwise specification stated in the Bill of Quantities or herein, all the work involved within scope of this section of specification shall be deemed to be inclusive of but not limited to the following:

- i) Contractor's establishment charges, over head charge, profit, interest.
- ii) All other expenses, charges, taxes specification in Condition of Contract.
- iii) Labor and all costs in connection there- with.
- iv) Use of plant, equipment and machinery and all costs in connection therewith e.g. mobilization, demobilization, transporting, fuel, energy charges, grease, oil, installing, operating, storing, watching, returning, handling, maintaining, idle stand parking, removing damaged, destroyed, salvaged items.
- v) Material and goods e.g. marketing, selecting. Conveyance, loading, unloading, storing, watching, returning, handling, hoisting, lowering, cutting, jointing, fixing, wastage, removing damaged, destroyed, salvaged material.
- vi) The cost of all laboratory and field tests including sampling stipulated in these specifications.

The Cost of all works involved within the scope of this specification as per all the contract are covered only within the quoted rate of items of the BOQ.

Measurement for payment shall be made on the basis of the superficial area in sq.ft / Sq.mt. of false ceiling fixed in position and the work to be done shall include providing and fixing of hangers, battens, tiles, paints, labor etc. all complete in every respect as shown on the drawings, and to the entire satisfaction of the Engineer.

SECTION - 15

15.0 **GLASS AND GLAZING**

15.1 **GENERAL REQUIREMENTS:**

- A. Contractor shall examine all other Sections of the Specifications for requirements which affect work of this Section whether or not such work is specifically mentioned in this Section.
- B. Contractor shall coordinate his work with that of all other trades affecting or affected by work of this Section.

15.2 **SCOPE**

Contractor shall provide all labour, materials, equipment, transportation and services required to complete all glass and glazing work as shown on Drawing, as specified herein, or both.

15.3 **SAMPLES**

- A. Contractor shall submit samples of all materials specified herein and obtain Engineer's approval before ordering materials.
- B. Samples of each type of glass shall be submitted to the Engineer for approval. Size of glass sample shall be at least 12 inch x 12 inch and shall bear the name of manufacturer, quality and weight or thickness on a printed label.

15.4 **SPECIFICATIONS AND STANDARDS**

- A. The whole of the glazing shall generally be executed in accordance with the recommendations of British Standard Code Practice CP 152. All glass shall comply with the appropriate section of BS-952.
- B. Except as otherwise indicated, all glazing shall be done in accordance with recommended practices and standards.

15.5 **QUALITY AND LABELING**

- A. Clear glass shall be flat-drawn clear sheet glass complying with B.S. 952 Section 1, Ordinary Glazing quality of the substances shown in Table-1. Clear plate glass shall comply with B.S. 952 Section 1, Table-3
- B. Wired Glass shall be of the best available quality with wire mesh embedded in glass meeting with Engineer's approval.
- C. All materials shall be free from defects impairing strength, durability and appearance. All glass shall be free from bubbles, pockets, chips, wavy surface or other defects.

15.6 **MANUFACTURERS**

Imported Glass from USA, Sweden etc. will be used.

15.7 **SHEET GLASS**

Glass shall be tinted, clear or wired as specified in the drawings. The thickness of sheet glass shall be according to the size of panel as given hereunder.

- | | | |
|----|---|------|
| a) | Not exceeding 1 sq. ft. | 2 mm |
| b) | Exceeding 1 sq. ft. but not exceeding 2 sq. ft. | 3 mm |
| c) | Exceeding 2 sq. ft. but not exceeding 4 sq. ft. | 4 mm |
| d) | Exceeding 4 sq. ft. but not exceeding 6 sq. ft. | 5 mm |

e) Exceeding 6 sq. ft. 6 mm

15.8 GLAZING SEALANTS, COMPOUNDS AND TAPE

- A. **Liquid Polymer Sealant:** Non-sag gun grade liquid polymer sealant, as approved by Engineer. Colour shall be white, grey or manufacturer's standard colors as selected by Engineer.
- B. **Elastic Glazing Compound:** Knife grade, wood or metal type, as required & approved by Engineer. Colour shall be white, gray or manufacturer's standard colors as selected by Engineer. It shall conform to B.S.S. 544.
- C. **Glazing Tape:** Polyisobutylene type, at least 1/8" thick, as approved by Consultant. Colour shall be white, gray or manufacturer's standard colors as selected by Engineer.

15.9 PREPARATION OF SASH AND FRAMES

- A. Before beginning work, glazier shall inspect sash and frames to determine that other trades have completed preparatory work and that sash and frames are ready to receive his materials.
- B. Frames and Sash : shall be adjusted, plumbed and squared. All rivets, screws, bolts, nail heads, welds and other projections shall be finished flush in glazing rabbets. All corners and intersections shall be sealed and weathertight.
- C. Operable Sash : shall be fastened and kept stationery until glazing compounds, except non-setting types, have cured or set.
- D. Surfaces to receive glazing materials shall be free of dirt, dust grease, oil and other foreign materials and shall be painted or sealed before work under this Section is begun.

15.10 INSTALLATION

- A. Do not begin glazing until all cleaning and repairing of concrete surfaces has been completed.
- B. Do not begin glass installation until rebates and glazing stops have been primed and are thoroughly dry.
- C. All glass shall be clean cut. Nipping to remove flares or to reduce oversize dimensions will not be permitted. Glass shall be shop-cut to fit openings allowing required clearance. Openings to receive glass shall be perfectly square. Protect edges of glass from abrasion with ground or masonry.
- D. Cut glass accurately to fit openings. Sizes of glass indicated on the drawings are approximate only and the actual sizes required shall be determined by measuring the frames to receive the glass. Size of glass to permit required clearance and bite around full perimeter of glass as per standard practices.
- E. Apply glazing compounds and other materials in strict accordance with manufacturer's printed recommendations.
- F. Glass shall be set without springing: with proper clearances at all edges. Edge clearance and tolerance shall be in accordance with recommendations of the manufacturers.

15.11 PROTECTION

- A. All glass shall be protected from damage until acceptance of the building and if broken or defective, shall be removed and replaced with glass of specified type. Glazing subcontractor shall protect and replace glass until his work is completed. Contractor shall be responsible for protection of glass and the replacement of all damaged glass after glazing work is completed.
- B. Glass breakage caused by Glazing subcontractor in executing his work or caused during installation due to faulty work shall be replaced by him at no additional cost to the employer. Glass breakage caused by subcontractors because of negligence or any other reason shall be replaced at the expense of the Contractor.
- C. All glass shall be examined to detect any formation of staining and/or etching. Plaster, mortar, paint spatter, or any other coating shall be removed immediately after contact and shall not be permitted to collect or remain on glass surfaces.

15.12 CLEAN-UP AND CLEANING OF GLASS

- A. Remove all labels, excess glazing compounds, stains and spots from glass on completion of glazing.
- B. Remove all rubbish and debris from the site at the end of each days work. Clean compound smears and stains from adjacent surfaces as the work progresses.
- C. At the completion of the entire job, Contractor shall have all glass surfaces thoroughly cleaned and washed by window cleaners.

15.13 MEASUREMENTS AND PAYMENT

No separate payment shall be made for the work covered under this section of the specifications and all costs in connection with items of work as described in this section shall be included in the Contractor's item rate for the items of windows, fixed glazings, Doors, ventilators etc. in the Bill of Quantities.

SECTION - 16

16.0 ROOF TREATMENT

16.01 SCOPE:

The work covered by this section of the specifications consists of furnishing all plant, labour, equipment, appliances and materials and in performing all operations in connection with the execution of the work of roof treatment complete, in strict accordance with this section of the specifications and the applicable drawings and subject to the terms and conditions of the contract.

16.02 MATERIALS:

- a) Cement, aggregate and coarse sand shall be in accordance with the specifications for "Concrete".

- b) Clay tiles (Manglore Tiles) as approved by the Engineer.
c) Samples of all materials proposed for use under this section shall be submitted to the Engineer for his approval.

16.03 **APPLICATION**

After all the surface to be treated has been broomed, and cleaned, a 2" (50 mm) thick average screeding with cement concrete 1:2:4 shall be laid over R.C.C. roof slabs in alternate panels as approved by the Engineer. The screed shall be finished in proper slope and level and shall have smooth finish.

After the concrete of screed has been cured and has set and dried, it shall be cleaned thoroughly to ensure that it is free from dirt, sand and Grease etc. Roof Clay Tiles of red colour approved by the Engineer shall then be placed on the roof and grouted with cement mortar.

16.04 **MEASUREMENT AND PAYMENT:**

Works shall be measured net acceptably completed and as applied in position conforming to the drawings and the instructions of the Engineer.

Unit rate for the Roof treatment work shall be deemed to be inclusive of all detail of this item mentioned in the BOQ (Roof Screeding, Water Proofing Membrane with primer, polystyrene and preparatory works, like scrapping, scratching, cleaning, etc . complete as per drawings, specifications and direction the Engineer.

SECTION - 17

17.0 **PAINTING, DISTEMPERING AND WHITE/COLOUR WASHING ETC.**

17.01 **SCOPE OF WORK:**

The work covered by this section of the specifications consists of furnishing all materials, plant, labour, equipment, appliances and performing all operations in connection with surface preparation, mixing, painting concrete works, gates, frames steel works, steel and wooden doors, windows, ventilators, walls ceilings and all such surfaces as shown on the Drawings and/or as directed by the Engineer. The scope of this section of specifications is covered with detailed specifications as laid down herein.

17.02 **GENERAL:**

Except as otherwise specified, all painting shall be applied in conformity with BS CP 231 "Painting of Building as applicable to the work".

The Contractor shall repair at his own expense all damaged or defective areas of shop-painted metal work. Metal surfaces against which concrete is to be placed will be furnished shop-painted and shall be cleaned prior to being embedded in concrete.

Except as otherwise specified, all concrete and plastered surfaces are to be painted.

17.03 **MATERIALS:**

All materials shall be acceptable, proven, top-grade products and shall meet or exceed the minimum standards of reputable manufacturers as approved by the Engineer.

Colors shall be pure, non-fading pigments, mildew-proof, sun-proof, finely ground in approved medium. Colors used on plaster and concrete surfaces shall be lime-proof. All materials shall be subject to Engineer's approval.

All enamel paints and primers for wood and metal work will be the best available of its type and shall be approved by the Engineer prior to its procurement.

Unslaked lime, gum and marine blue shall be used for white washing.

DUROCEM a cement base heavy duty water proof coating manufactured by ICI or any equivalent approved by the Engineer shall be used for painting on the surface specified. The cement base water proof coating for concrete shall conform to ASTM C-109,C-67, D-822 and G-23.

All materials shall be delivered to site in their original unbroken containers or packages and bear the manufacturer's name, label, brand and formula and shall be mixed and applied in accordance with his directions.

17.04 **SURFACE PREPARATION:**

All oil, grease, dirt, dust, loose mill, scale and any other foreign substance shall be removed from the surface to be painted, polished and white washed by the use of a solvent and clean wiping material. Following the solvent cleaning, the surfaces shall be cleaned by scraping, chipping, blasting, wire brushing or other effective means as approved by the Engineer.

In the event the surface becomes otherwise contaminated in the interval between cleaning and painting, recleaning will be done by the Contractor at no additional cost.

Surfaces of stainless steel, aluminium, bronze and machined surfaces adjacent to metal work being cleaned or painted shall be protected by effective masking or other suitable means, during the cleaning and painting operations.

No work in this Section shall be allowed until all surfaces or conditions have been inspected and approved by the Engineer.

17.05 **APPLICATION:**

All paint and coating materials shall be in a thoroughly mixed condition at the time of application. All work shall be done in a workmanlike manner, leaving the finished surface free from drips, ridges, waves, laps and brush marks. All paints shall be applied under dry and dust free conditions. Unless approved by the Engineer paint shall not be applied when the temperature of the surrounding air is below 10 Deg.C. Surfaces shall be free from moisture at the time of painting.

All primary paint shall be applied by brushing. The first coat of paint shall be applied immediately after cleaning. When paint is applied by spraying, suitable measures shall be taken to prevent segregation of the paint in the container during painting operations.

Effective means shall be adopted for removing all free oil and moisture from the air supply lines of the spraying equipment.

Each coat of paint shall be allowed to dry or harden thoroughly before the succeeding coat is applied. Surfaces to be painted that will be inaccessible after installation shall be completely painted prior to installation shall be completely painted prior to installation.

Only as much material should be mixed as can be used up in one hour. Over-thinning will not be permitted. After the first coat, the surfaces will be soaked evenly four or five times and the second coat shall be applied after leaving for at least overnight.

All steel doors, windows and ventilators shall be painted with two coats of approved enamel paint over one coat of a redoxide primer as directed by the Engineer.

Oil bound distemper shall be applied to internal wall surfaces and white wash on ceilings as specified herein after.

For applying Durocem the surface shall be dampened with clean water immediately ahead of application. Durocem and clean water shall be mixed as per directions of the manufacturer. A heavy first coat at 20 lbs/100 sft (1 kg per sq.m) shall be applied. This shall be followed by a second brush coat at 10 lbs/100 sft (0.5 kg per sq.m) after the first coat has set. When finish coat has set, it shall be floated to uniform texture with a sponge float. The work shall include cleaning the surface, sand papering and smooth finishing, scaffolding, curing etc. complete as per the approval of the Engineer.

17.06 WHITE AND COLOUR WASHING:

The surfaces shall be well cleaned and brushed before white washing. The white washing material shall be prepared from un-slaked lime. The lime shall be dissolved in a tub with sufficient quantity of water and then well mixed and strained through a clean cloth. 4 kg clean gum boiled with 12 kg of rice for each cu.m of lime shall be added to the liquid lime along with a small quantity of marine blue as directed by the Engineer.

The mixture shall be in thoroughly mixed condition and shall be applied in three coats with a brush.

Each coat of white wash shall be allowed to dry, so that no sign of cracking shall appear on the surface and also white wash shall not come off readily on fingers when rubbed. The white wash when completed, shall form an opaque coat of uniform white colour, through which the old work does not show and shall present a smooth regular surface free from Powderly matter. For colour washing approved quality of coloring matter shall be added to the liquid and thoroughly mixed by stirring.

17.07 DISTEMPERING:

Oil bound distemper of approved quality and shade shall be applied on internal wall surfaces where shown in drawing or directed by the Engineer.

17.08 EXECUTIONS:

17.09 SUBMITTALS

Colour samples shall be submitted on 6"x6" (150x150 mm) asbestos cement boards, showing each type of paint for Engineer's approval.

17.10 PRODUCT DELIVERY

Deliver materials in manufacturer's original unopened containers with labels intact and legible identifying brand names and contents.

17.11 JOB CONDITION

Observe manufacturer's recommended minimum and maximum temperature but do not apply paint or finish to any surface unless ambient temperature is 10 deg.C or above and less than 43 deg.C. No painting shall be done above 90% relative humidity.

Place drop cloths to adequately protect all finished work.

Remove and replace all items of finished hardware, device plates, accessories, including fixtures or other removable items.

The surface shall be prepared first before applying distemper by filling depressions with putty, rubbing, sand papering and cleaning. A priming coat shall first be applied of petrifying liquid of approved manufacture. Distemper shall be applied with broad stiff brush of approved make. Distemper shall be applied quickly and boldly. Each coat of distemper should first be got approved by the Engineer before applying the next coat.

17.12 MEASUREMENT AND PAYMENT:

Measurement of the work acceptably completed and specified herein as painting, distempering, and white/colour washing etc. will be made on the basis of actual area in square feet of the respective job including all preparatory work like scraping, scratching, sand papering, filling depressions with putty, priming and scaffolding etc. complete in all respect as directed by the Engineer. Payment under covered in this section shall be made as per unit rates entered in the BOQ. No payment shall be made for painting work on doors, windows, ventilators, steel grills, cabinets and cup boards steel ladders etc. for which the contractor shall make necessary allowance in his rates for such items.

SECTION - 18

18.0 COLOUR CREATING / SNOW CREATING

18.01 MATERIAL

Cement shall be of specified colour and approved make and shall conform to the latest specification for Portland cement. If cement of approved shade is not available the contractor may be allowed to make the coloured cement by mixing approved pigment.

- 18.02 Marble chips of approved quality shall be of the colour or colours mixed in particular proportion as specified in the schedule of quantities; and where it is not so specified these will be provided as per direction of the Engineer-in-Charge. The chips shall be of zero number unless otherwise, directed.
- 18.03 The marble powder shall be free from all dust and dirt and shall be of approved quality.
- 18.04 **PREPARATION OF SURFACE**
The surface of over which the colour create / Snow create is to be applied shall be well-hacked or roughened to form a mechanical bond. The surface must be well soaked with water. The water should be allowed absorbed into the surface to be rendered and the first coat applied when there is just a slight amount of moisture left on the surface. The thickness of the base coat shall be as specified in the schedule or quantities. The finishing coat of Colour create / Snow create shall be applied 48 hours after, applying the base coat.
- 18.05 The first coat shall be composed of ordinary Portland cement and sand in the proportion specified in the schedule of quantities. The coat shall be well pressed and deeply secured to the surface. The surface shall be well combed to provide at key for the following coat.
A minimum of 48 hours should elapse before the finishing coat is applied.
- 18.06 It shall be composed of marble chips, marble Powder and Snow create / Colour create / cement mixed with Pigment, in the specified proportion. Before applying the finishing coat the surface should be sufficiently wetted.
Where provided in the schedule of quantities grooves or required dimensions shall be made with special tools all over the surface to sub-divide it into blocks of the shown in the drawing or as directed by Engineer-in-Charge. The grooves must be uniform in depth and width throughout being taken out in the approved shape. The grooves must run horizontally and vertically to be exactly parallel and / or perpendicular to each other unless otherwise specified.
Where required in the schedule of quantities the surface of Snow creates Colour create shall be chiselled in an approved manner with sharp tools as directed by the Engineer-in Charge.
- 18.07 The surface must be cured for a period of 7 days in a suitable mariner approved by the Engineer-in-Charge.
- 18.08 **MEASUREMENT AND PAYMENT:**
Measurement and Payment under covered in this section shall be made as per unit rates entered in the BOQ.

SECTION - 19

19.0 **STEEL WINDOWS, VENTILATORS, ETC.**

19.1 **SCOPE OF WORK:**

The work covered by this section of the Specifications consists of furnishing, transporting and storing all plant, equipment, appliances labour and material and in performing all operations in connection with the fabrication, welding, erecting and painting of steel units complete in strict accordance with the drawings and/or as directed by the Engineer.

19.2 **MATERIALS:**

All materials shall be new of the best standard commercial quality and shall be approved by the Engineer.

All the angles, squares, sheets and channels etc., shall conform to BS 4360.

19.3 **CAST IRON:**

Cast iron should of good grey metal, sound, free from all flaws such as pitting due to impurities or sand from the pattern, cold shuts (i.e., irregularities due to casting at too low temperature, blow-holes etc.). It should have a clean smooth surface, true to pattern.

19.4 **WROUGHT IRON:**

Wrought iron should be of good tough metal with an even silky fibrous grain which will be apparent if twisted and bent. A good iron must be neither cold short (i.e., brittle when cold due to production from and inferior core) nor hot short (i.e., a tendency to cracking at the surface edges when working at red hot due to the presence of sulphur).

19.5 **DRAWINGS:**

The Contractor shall prepare all necessary shop and erection drawings covering the steel to be furnished under these Specifications. No fabrication and erection shall be taken in hand until these drawings have been approved by the Engineer.

All work under this section shall be coordinated with the work to be done as specified under other sections of the Specifications.

The Contractor shall drill, tap, cut and fit the work included herein as required, to accommodate work of other trades in conjunction with it.

The Contractor shall furnish all information and instructions required for work by other trades.

Samples of material specified shall be submitted for approval when required by the Engineer.

19.6 **FABRICATION:**

All work shall be equal to the best modern practice in the manufacture and fabrication of structural steel notwithstanding any omission from these specifications or Drawings. All fabrications shall conform to BS-449.

Before being laid out or worked in any way, the steel shall be straight and free from kinks and bends. If straightening is necessary it shall be done by methods that will not injure the metal. Shearing and cutting by torch or electric shall be performed carefully, and all portions of the Work which will be exposed to view after completion shall be finished neatly.

All holes shall be cylinder, unless otherwise shown on the Drawings, perpendicular to the member and clean cut without burred or ragged edges. Holes in the material shall be drilled to full size and shall be accurately and carefully

placed. The length of bolts shall be in 1/4 of an inch variation, and when in the steel gate, the bolts shall extend at least 1/4 of an inch beyond the nuts.

19.7 **WELDING:**

Welding shall be done by qualified and licensed welders under the supervision of expert fabrication Engineers. All the welding shall be executed according to BS 538.

All defective and damaged works shall be rejected at the sole risk and cost of the Contractor.

Where welding is required in the works as per drawings or as required by the Engineer, the welding shall develop the full strength of the adjoining steel.

19.8 **ERECTION:**

The method of erection and propping the gates, frames, windows and ventilators shall be according to the Drawings or as directed by the Engineer. The engineer shall inspect and approve all the equipment, temporary works and other measures proposed to be adopted for the erection and safety of the steel sections. The contractor shall be responsible for the safety of damage to any person or to any part of the building while the work is in progress.

All steel sections shall be accurately assembled and erected as shown on the Drawings, on the scheduled dates in complete harmony and coordination with the progress of other construction works in the building. All of the material shall be handled carefully so that no part will be bent, broken or damaged otherwise. Hammering that will injure or distort the members will not be permitted.

Prior to erection of the steel, all shoe plates, down holding bolts etc., shall be fixed / grouted dead accurate in levels and alignment as per details shown on the drawings or as directed by the Consultant.

19.9 **HARD WARE:**

All required hardware like handles, locking devices where required, stays and latches etc. for windows and ventilator shall be provided. Samples of all items of hardware, accessories and other items requested by the Engineer shall be submitted for his approval.

19.10 **GLAZING:**

Glass shall be as specified and shall be framed on all four sides. Glazing beads, gaskets, glass adapters and glazing compound shall be provided as specified or approved by the Engineer.

19.13 **CAULKING:**

All fixed joints between various parts of windows and ventilator assemblies shall be buttered with caulking compound before the windows are assembled. All joints between windows and ventilators and surrounding masonry or concrete construction shall be caulked with approved caulking compound.

19.14 **MEASUREMENT AND PAYMENT:**

All the steel door, ventilators and gate shall be measured between top of the frame and finished floor level or bottom of frame vertically and between the outer edges of the frame horizontally and paid for at the unit rates entered in the Bill of Quantities and shall be inclusive of finishing hardware, glazing, painting etc. as specified and shown in drawings, complete in respects.

SECTION – 20

2.0 **STRUCTURAL STEEL WORKS**

20.1 **SCOPE**

This Section covers requirements of steels, steel work, fabrication, methods including precautions for erection of steel structures and other general requirements incidental to steel work.

20.2 **GENERAL**

The applicable requirements of this section as determined by the Engineer shall apply to all structural steel works under this contract. The work covered by this Section consists of all material, labour, plant, equipment and appliances including welding, bolts, nuts, washers, anchor bolts, embedded parts etc, fabrication and erection in accordance with the specifications and as per drawings and as directed by the Engineer.

20.3 **DRAWINGS**

20.3.1 **Design and Working Drawings**

These shall be prepared by the Engineer and supplied to the Contractor. These shall contain main dimensions, sizes of member & typical details of joints, list of material etc.

20.3.2 **Workshop Drawings**

a) Before proceeding with the manufacture, or fabrication, Workshop drawings shall be prepared by the Contractor from the working drawings supplied, taking into consideration the following instructions:

- Fabrication in convenient sub-assemblies and each shop assembly to be given an erection mark.
- Milling (machining of bases of supporting plate) for erection without adjustments.
- Provision of basic elements for/with erection devices.
- Keeping with the requirements of computed strength of all connections and joints of structures not foreseen in the design and working drawings.
- Other requirements having an influence on the technology of fabrication transportation and erection of steel structures.
- Uniformity of elements and parts of the steel structures should be maintained for mass fabrication.

b) Workshop drawings shall consist of two parts:

1. An erection scheme having the following information:

- Location of erection element in respect of these elements with each other or with the existing steel or reinforced concrete structures.
- Erection joints showing erection welding thickness and lengths, bolts or rivet diameter and numbers.
- Chart showing list of assembling marks having columns such as Mark, Description, Quantity, Weight of each Mark, Total weight and Remarks with grand total in the end.
- Chart showing list of Erection Bolts, Nuts and Washer having columns such as size, quantity, weight and notes with grand total.
- The mark for shop assemblies of each erection scheme shall have a different index for example scheme of trusses purlins etc. shall have Marks A1, A2, A3, onwards and another scheme of columns beams etc. shall have Marks B1, B2, B3 and onwards. While marking on the plans, elevations, sections and details the index shall be omitted.
- The recommended scale of erection scheme is 1:50, 1:100, 1:200, for joints 1:5, 1:10 or 1:20.
- Except in special cases all scheme drawings shall be made in single fairly thick lines.
- Erection Scheme shall contain the following notes:
 - i) Erection shall be done using the erection welding and bolts of normal sizes and accuracy according to the joints of the scheme.
 - ii) Quality and type of electrode.
 - iii) Measures against unscrewing of bolts.
 - iv) Erection shall be carried out according to the standard for fabrication and erection of steel structures.
 - v) Painting instructions.
 - vi) References to design and working drawings.
- 2. A shop assembly drawing containing the following information:
 - Each Shop Assembly (Mark) shall be drawn separately showing necessary lines, elevation sections with reference to axis, centre lines, location of holes, cleats, plates lugs etc .fully dimensioned with part numbers.
 - Bolts, holes and symbols.
 - Geometrical Setting out dimensions necessary for the assembly of an element. Location and details of joints as calculated by the Fabricators / Engineer.
 - Instruction for welding, dimensions of weld (Seams) processing of edges, methods of welding, quality of welded material, length of welds on every element, requirements for welding and method of their control. Specification for Electrode selected according to specification of steel.
 - Standards and quality of steel used.
 - Parts List.
 - Instruction for painting, primer and finish coats with derusting process.
 - Recommended scale for assembly drawings are preferably 1:10 or 1:20 and for joints and details 1:1, 1:2 or 1:5.
 - Notes for assembly drawings shall be as follows:
 - i) List of symbols for bolts and holes used.
 - ii) List of symbols for welds used.
 - iii) Edge distance (general).
 - iv) Welding thickness (general).
 - v) Material quality of steel used.
 - vi) Type and quality of electrodes to be used.
 - vii) Test for welding if any.
 - viii) Reference to related erection scheme drawings.
 - ix) Reference to design and working drawings.

20.4 MATERIAL

Except otherwise required or stated in the drawings the materials specifications shall conform to the following. Wherever necessary Contractor may use equivalent British Standard or other alternative material subject to approval of the Engineer. Material shall generally conform to the applicable requirement of ASTM A-6.

a) Structural Steel

- Structural steel for structures not requiring Welding shall conform to the requirements of ASTM A-7-66 (for bridges and buildings) or ASTM A-36-77.
- Structural steel for structures requiring welding shall conform to the requirements of ASTM A-36-77 or approved equivalent.

b) Sheet Steel

Sheet steel for structures where no welding is required shall conform to the requirement of ASTM A-366-62T (for Cold Rolled Carbon Steel Sheets commercial quality) or ASTM A-415-64 (Standard specifications for Hot Rolled Carbon Steel Sheets, commercial quality). For structures where welding is required sheet steel shall conform to the requirements of ASTM A-415-64 and steel plate to ASTM A-283-79 (Low and intermediate strength carbon steel plate) or A-514-77 (High-yield-strength, quenched and tempered alloy steel plate, suitable

for welding as required.

c) Filler Metal for Welding

Welding Electrodes for manual shielded metal arc welding shall conform to the specifications for mild steel covered Arc-welding Electrodes, AWS A 5.5 (latest edition). Equivalent locally manufactured electrodes by Pakistan Oxygen may also be used subject to the approval of the Engineer.

d) Ordinary Bolts, Nuts and Washers

Bolts and nuts shall conform to the requirements of ASTM A-307-65 (Standard specification for low-alloy, carbon steel, externally and internally threaded, standard fasteners). Bolts shall be of Grade A for general application with square or hexagon heads as specified in the drawings. Turned bolts shall also conform to the requirements of ASTM A-307-65, except that the tolerance of the unthreaded portion of the bolt body shall be +0.0 - 0.15 mm of the diameter.

e) Cut Washers

Shall be of structural grade steel and shall conform to the dimension of the manufacturer's regular standard for plain washers for the size and type of bolts used.

f) Cast Iron

Shall conform to the requirements of ASTM A-48-64 (Standard specifications for Grey Iron Castings) or equivalent.

g) Iron Pipe

Where iron pipe is called for, it shall be genuine wrought iron fully galvanized. All Threads to be cleaned and coated with rust resistant coating.

h) Painting Materials

Paintings materials which include emulsions, epoxy based enamel paints, sealers, primers, wax, varnishes etc., shall be standard best or top brands produced for each particular kind of material required.

20.5 **ALLOWABLE STRESSES**

- a) Allowable stresses for steel shall be considered tabulated in Appendix A of specifications for the Design, fabrication and erection of structural steel for buildings; Part 5 of the Manual of Steel Construction published by the American Institute of Steel Construction.
- b) Allowable stresses for rivets, bolts and threaded parts as per table 1.5.2.1 of AISC specifications.
- c) Allowable stresses for welds as per table 1.5.3 of AISC specifications.

20.6 **FABRICATION**

a) Straightening Material

Rolled material, before being worked upon, must be straightened within tolerances by ASTM specifications A6. Straightening, necessarily shall be done by mechanical means or by the application of limited amount of localised heat. The temperature of heated areas, as measured by approved methods, shall not exceed 1100 F for A514 steel or 1200 F for other steels. All material, before and after fabrication shall be straight or curvilinear form as required free from twists.

b) Cutting

As far as possible cutting must be done by shearing. Oxygen cutting shall be done where shear cutting is not possible and shall preferably be done by machine. All edges shall be free from gauges, notches or burs. If necessary the same shall be removed by grinding.

c) Holes punching drilling

Holes shall be punched where thickness of the material is not greater than the diameter of bolt or rivet + 3mm. Where the thickness of the material is greater, the holes shall be drilled or sub-punched and the drill of all sub drilled holes shall be at least 2mm smaller than the nominal diameter of the rivet or bolt. Holes for A514-77 steel plates over 1/2" thick shall be drilled. Holes shall not be allowed to formed gas cutting process.

d) Welding

- 1. Maximum Thickness of fillet welds
 - i) Not more than 1.2 times the lesser thickness of materials being welded.
 - ii) At welding of rolled profiles along edges, which are curved, not more than the thickness of the edge minus the radius of the curve.
- 2. Minimum thickness of fillet welds.
Least thickness for calculation and designing requirements:

Thickness of thicker part	Upto 10 mm	11mm to 20mm	20mm to 30mm	31mm to 50mm	Above 50mm
Thickness of Weld for carbon steel.	4	6	8	10	12
Thickness of Weld for low alloy steel	6	8	10	12	-

- 3. Design length of a fillet weld shall not be less the 40 mm or 10 times thickness of fillet weld and not more than 60 times thickness of fillet weld.
- 4. Surfaces to be welded shall be free from loose scale, slag, rust, grease, paint or any other foreign matter

except mill scale which withstands vigorous wire brushing.

e) Tolerances

1. A variation of 1 mm is permissible in the overall length of members with both ends finished for contact bearing. The bearing surface is to be prepared to common plane by milling.
2. Members without end finished for contact bearing which are to be framed to other steel parts of the structure shall have a variation from detailed length not greater than 3mm.

f) Each piece of steel work after fabrication shall be distinctly marked before delivery to site in accordance with a marking plan for erection assembly.

20.7 **SURFACE PREPARATION**

a) All steel work shall be cleaned free from loose scale, rust, dust, slag etc. by using suitable means. Sand blasting shall be carried out wherever so specified by the Engineer.

b) Steel work to be encased in concrete or surfaces in contact with concrete or grout shall be given a cement wash.

c) Machine finished surfaces shall be coated with rust preventive compound approved by the Engineer prior to removal from shop and immediately after finishing. Such surfaces shall be protected with wooden pad or other suitable means for transportation. Unassembled pins and bolts shall be oiled and wrapped with moisture resistant paper.

d) All other surfaces of steel work shall be painted as specified hereunder.

- Resin based special emulsion paint shall be manufactured by one of Pakistan paint manufacturers, as approved by the Engineer. The paint shall be composed of P.V.A. with pigment of Titanium dioxide with inert extenders, having viscosity of 70-75 K.U. at 25 deg. C and approximate specific gravity of 1.33. The paint shall have flat finish, smooth and free from brush marks and resistant to fungus growth.
- Enamel paint and primers shall be Dulux as manufactured by M/S Imperial Chemical Industries Pakistan Ltd. or approved equal and shall be applied in accordance with the period instructions of the manufacturers.

No separate payment shall be made for painting of structural steel works. The Contractor shall include all the cost of labour, plant and material for this work in the price as mentioned in the Bill of Quantities.

20.8 **ZINC COATING (GALVANIZING)**

Where ever specified by the Engineer zinc coating shall be applied in a manner and or a thickness and quality conforming to the requirements of ASTM A-123-65, standard specifications for zinc (Hot galvanized) coating on products fabricated from rolled, pressed, and forged steel shapes, plates, bars and strips.

20.9 **INSPECTION AND TESTS**

a) Manufacturer's Works Test certificate for all material used shall be furnished by the contractor for Engineer's scrutiny and approval. The contractor shall provide all necessary facilities to Engineer for inspection of steel structure work during fabrication and erection.

b) Rolling tolerance of all shapes and profile according to AISC (American Institute of Steel Construction) shall be in accordance with the provisions of the American Society for Testing and Materials Designation A.6 These shall be checked by the Contractor before being worked upon and shall be rejected if found not within limits.

c) The Contractor shall arrange for analysis and test of all material rolled locally at a testing laboratory selected by the Engineer, for which Contractor will bear all expenses.

d) Nevertheless neither the fact that the materials have been tested nor that the manufacturers works test certificates have been furnished shall effect the liberty of the Engineer to reject after delivery, material found not according to these specifications.

e) The inspection of welding shall be performed in accordance with the provisions of Section 6 of the code for Welding in Building Construction, DI. O-69 of the American Welding Society ("Structural Welding Code" AWS D1-1)

f) Materials or workmanship not in reasonable conformance with the provisions of these specifications shall be rejected at any time during the progress of the work or the completion and erection at site.

20.10 **ERECTION**

a) Bracing.

The frame of steel skeleton buildings shall be carried up true and plumb within the limits defined in section 7(h) of the AISC code of standard practice, and temporary bracing shall be introduced wherever necessary to take care of all loads to which the structure may be subjected including the equipment and the operation of the same. Such bracing shall be left in place as long as required for safety. Wherever piles of material, erection equipment and other loads are carried during erection, proper provision shall be made by the contractor to take care of the stresses resulting from such loads.

b) Alignment & Bolting.

No riveting, permanent bolting or welding shall be done at site during erection until as much of the structure as will be stiffened thereby has been properly aligned. The threaded portion of each bolt shall project through the nut at least one thread.

c) Painting after Erection.

Before painting of steel which is delivered unpainted is commenced, all surfaces to be painted shall be dry and thoroughly cleaned from all loose scale and rust. The specified protective treatment shall be completed after

erection.

20.11 MEASUREMENT & PAYMENT

a) General

- i) The cost of all the works involved within the scope of this specifications as per all the drawings and conditions of contract are covered only within the quoted rate of items of the Bill of Quantities.
- ii) Unless otherwise specified and to the extent provided in the Bill of Quantities no separate or additional payment will be made for the following works, the cost of which shall be deemed to have been included in the quoted rate of the Bill of Quantities item.
 - Providing nuts, bolts, screw, rivets, heads, filets welds and welding rods.
 - Galvanizing and prime coating steel work.
 - Painting Steel Work.
 - All embedded parts other than steel.

b) Measurement

- i) Items of work of structural steel for which the unit rates have been quoted on weight basis shall be measured net as acceptably supplied and installed at site as per drawings / workshop drawings and as per instruction of the Engineer. After measurement the theoretical weights shall be calculated from standard tables of section and weights in the manner followed in the preparation of workshop drawings. The cost of loading and unloading, transportation and handling of structural steel items shall be deemed to be included in the quoted unit rate of the related Bill of Quantities item.
- ii) Measurement of acceptably completed installation and erection works of Structural steel items supplied free of cost by the Employer will be made on the basis of number of tons of structural steel items erected and installed in position as shown on the drawings or as directed by the Engineer. The cost of loading and unloading, transportation and handling of structural steel items shall be deemed to be included in the quoted unit rate of the related Bill of Quantities item.

20.12 PAYMENT

Payment will be made for acceptable measured quantity of structural steel works on the basis of unit rate quoted in the Bill of Quantities and shall constitute full compensation for all the incidental works related to the item.

ELECTRICAL WORKS

E.1.1 General

The general instructions are given to the tenderers elsewhere in this contract document. The additional instructions in the following paragraphs are given in order to invite the tenderer's attention towards some major points pertaining to electrical work only and to assist them in preparing tenders. These instructions shall be deemed as Technical Provisions of the Contract.

E.1.2 Scope of Work

The Work consists of furnishing all tools, plants, labour, materials and equipment and performing the internal and external electrical Works comprising of :

- a) Light and Power Wiring
- b) Fans and Fixtures
- c) Wires and Cables
- d) L.T. Switchgear.
- e) Distribution Fusegear
- f) Earthing System
- g) External Lighting

The Work shall be carried out in strict accordance with the Conditions of Contract, Special Conditions, Drawings, Technical Specifications and as per items of Bill of Quantities and including the responsibility of all related works necessary for their proper functioning, testing, commissioning and satisfactory operation and performance including maintenance for the period specified elsewhere. The Contractor shall provide for all required technical and non-technical personnel, skilled and non-skilled labour, construction equipment, transportation etc. as required for the completion of Work in strict accordance with the Technical Specifications laid herein-after.

E.1.3 Prequalification

The Electrification Work shall be carried out only by a licensed Contractor authorized to undertake such work under the provision of Electricity Act. 1910, and the Electricity Rules, 1937, as adopted and modified by the Government of Pakistan.

E.1.4 Qualification

A licensed Electrical Contractor should have the following qualifications:-

- a) Must have in his employment a competent graduate Electrical Engineer registered with Pakistan Engineering Council, Islamabad.
- b) Must possess a valid Electrical Contractor's License issued by the Electric Inspector of the region where the site is situated.
- c) Must have in its employment an Electrical Supervisor having certificate of Competency who will exclusively supervise this Work.
- d) Must have necessary tools, plant and instruments.
- e) Must have adequate experience of similar works.

If a Contractor does not possess the above qualifications he shall be allowed to sublet the Work to a competent Sub-Contractor provided an application for his pre-qualification is made to the Engineer for his approval. Decision of the Engineer in this case shall be binding on the Contractor,

E.1.5 Rules and Regulations

The installation in general shall be carried out in conformity with the Electricity Rules, 1937, and the latest edition of the Regulations for the Electrical Equipment of Buildings issued by the Institution of Electrical Engineers London (I.E.E.). However, in case of conflict between these Specifications and the I.E.E. Regulations, these Specifications shall be followed.

E.1.6 Standards

The latest relevant British Specifications and Codes, Pakistan Standard Specifications, VDE, I.E.C. and I.E.E. recommendations shall be applicable and be followed for the equipment specified herein.

E.1.7 Climatic Conditions

All equipment supplied shall withstand, without developing any defect, the following climatic conditions:-

Maximum Ambient Temperature	=	113 deg F or	45 deg C
Minimum ambient Temperature	=	28 deg F or (-)	2.2 deg C
Maximum Humidity	=	90%	

E.1.8 Specifications

The Contractor shall furnish all material and equipment at site, conforming fully to the Specifications given herein and to the accepted standards as laid down by British Standards, the Institution of Electrical Engineers, London, and the Pakistan Standard Institution. It is not the intent of these Specifications to include all details of design and construction of various material and equipment to be supplied under this Contract. The Contractor shall supply and install all material and equipment specified herein and also all installation and small material such as nuts, bolts, washers, shims angles, leveling material, insulation, tape, solder, etc. and all such other material whether specified herein or otherwise required for complete installation as intended by the Specifications.

All material and equipment supplied by the Contractor shall be new and in all respects conform to the high standard of engineering design and workmanship, perform and function as herein specified and fully meet the quality level and ruggedness requirement of the Specifications. All material and equipment which have to be supplied and installed by the Contractor shall be passed/approved by the Engineer; even if the same is exactly in accordance with the Bill of Quantities and drawings.

E.1.9 Submittal

The Contractor, after the award of Work, shall submit for approval of the Engineer all drawings and cuts of equipment, appliances, fixtures and accessories that are to be furnished under the contract. After final approval of a sufficient number of copies as desired shall be furnished for distribution. Cuts, catalogues and drawings shall be clearly marked to indicate, the items furnished. Cuts of all fixtures, and not a few, shall be submitted.

E.1.10 Approval of Drawings and Data

The Contractor shall provide detailed electrical drawings, wiring diagrams, foundation details, etc. for all electrical switch gear, fuse gear and all other systems etc. for the Engineer's review and approval. Three sets of equipment drawings shall be provided for obtaining approval.

The manufacture of electrical equipment shall be started only after the above mentioned drawings and data are approved.

The time required for review and approval shall be considered included in the total time of completion of job.

E.1.11 Drawings & Data

Three sets of drawings and data for each equipment shall be furnished by the Contractor for the Engineer's approval before commencement of fabrication and manufacture. The drawings to be supplied by the Contractor shall be as follows:-

Structural Drawings showing:-

- Arrangements
- Dimensional Plans, elevations and front view
- Foundation Plan, anchor bolt locations
- Buss bar locations and configurations
- Incoming and outgoing cable terminal positions
- Terminal block locations
- Earthing arrangement

Electrical Drawings showing :-

- One-Line diagram
- Detailed wiring diagram
- All interconnections
- Instrument transformers
- Relays, their locations and internal wiring diagrams
- Other electrical devices including meters instruments and their wiring diagram
- Signal and alarm circuits

E.1.12 Shop Drawings

The design drawings do not show conduit routes and depict only the position of various fixtures and outlets. All the planning for the conduit routes shall be carried out, well in advance of the actual execution of work, by the Contractor to the satisfaction of the Engineer. For this purpose the Contractor shall prepare shop drawings and obtain prior approval of the Engineer. Three prints of each shop drawings shall be submitted for obtaining approval.

No piece of Work shall be allowed to be executed at site without the availability of these approved shop drawings. These shop drawings shall clearly depict the load balancing chart of each Distribution Board. Time required for the preparation and approval of shop drawings shall be considered to have been included in the total time allowed for the completion of the Work.

E.1.13 Setting out of Work

The Contractor shall set out the Work himself and if any discrepancy is found, he shall report the matter to the Engineer and shall act as directed. If any defective or modified setting out is carried out by the Contractor on his own, he shall rectify or make it good at his own cost.

E.1.14 Programming

The Contractor shall keep pace with the Work of the Civil Contractor and any other Specialist contractor. The Engineer shall be kept informed about the programme and the progress of Work so that there is no hindrance in the execution of Work at site.

E.1.15 Protection

The Contractor shall take care not to damage the structure, material, equipment and property belonging to and/or installed by other Contractors during execution of Work and shall repair and make good all losses at his own cost, if found guilty in the opinion of the Engineer.

E.1.16 Change of Specifications

No change in Specification of the equipment/material will be allowed at any stage, except with the prior approval of the Engineer before the opening of Tenders.

E.1.17 Purchase of Equipment/Material

All the equipment and material e.g. transformers, switch gear, fuse gear, cables, conduits, light fixtures and fans will be purchased direct from the manufacturer/authorized dealer to ensure the use of genuine material. Manufacturer's certificate and copies of delivery challans for all such material will be produced as and when desired.

E.1.18 Manufacturers and Brands

Where brands and names of Sub-Station equipment or any other system are specified by name, alternative can be offered provided these are equal in quality to those specified. Satisfaction of the Engineer in this respect shall be essential and prior approval for such deviation shall have to be obtained before submission of Tenders. However all equipment for any one substation or system shall be from one manufacturer only.

E.1.19 Factory Tests

All routine type tests on switch gear, fuse gear, and other equipment shall be performed at the manufacturer's factory in the presence of the Engineer. The Contractor shall inform the Engineer about the date and time of tests on each equipment at least two weeks in advance. All test results shall be supplied in triplicate for the Engineer's record. The witnessing of tests by the Engineer shall not absolve the Contractor of his responsibility for the proper functioning of the equipment, and for furnishing the guarantee.

E.1.20 Owner's Supplied Material

Material and equipment if supplied by the Owner shall be made available at site store to the Contractor for installation. Any lead and lift upto and within the site of Work shall be at the cost and responsibility of the Contractor. The Contractor shall ensure safe handling and proper protection after the material and equipment are issued to him at site store and shall provide and maintain required plant and equipment for handling, proper protection and installation at his own cost.

E.1.21 Spare Parts List

A list of spare parts required for one year's operation of each equipment where deemed necessary together with unit price of each part, shall be supplied by the Contractor.

E.1.22 Guarantee

The Contractor shall furnish written guarantee in triplicate of the manufacturer for successful performance of each equipment. Such guarantee shall be for replacement which may be found defective in material or workmanship. The guarantee shall cover a minimum period of 12 months effective from the date of completion certificate.

E.1.23 As-Built Drawings

The Contractor shall, during the progress of work keep a careful record of all changes and revisions where the actual installation differs from that shown on shop drawings. These changes and revisions shall be accurately carried out on the shop drawings and submitted to the Engineer for approval. After approval these drawings shall become the property of the Owner. These updated and approved shop drawings depicting clearly all changes and revisions at site shall be called As-Built Drawings. Reproducible tracings with two sets of prints of all these As-Built Drawings shall be handed over to the Engineer. Final payment will be withheld until the receipt of the approved As-Built Drawings.

E.1.24 Test Reports

The Contractor shall be responsible for submitting the test reports/certificates and get the installation inspected and passed by the Regional Electric Inspector.

E.1.25 KE Requirement (If required)

The Contractor on behalf of the Owner shall submit application for Electrical Connection, liaise with KE and carry out necessary formalities and shall be responsible for obtaining the required electrical load/extension in load. Any special

requirement of KE shall be in compliance with by the Contractor. The Owner shall arrange to deposit all amounts, on demand, to KE for providing service connection and security deposits thereof.

SECTION 2.1 - CONDUITS & CONDUIT ACCESSORIES

E.2.1.1 Conduit Pipe

The conduit for wiring of lights, socket outlets and other systems shall be made of PVC manufactured by as approved manufacturer conforming to BSS 6099.

The conduit shall have following wall thickness and standard weights :-

Pipe Size	Wt/100Rft.	Wall thickness
3/4" dia	3.4 Kg. .	04" to .05"
1" dia	4.5 Kg. .	045" to .055"

Steel conduit shall conform to BSS 31/latest and shall be of International brands. The conduit shall be enameled with good quality non-cracking and non-flaking black paint.

E.2.1.2 Flexible Pipe

Flexible conduit shall be furnished and installed where necessary for convenient dismantling and/or avoiding vibrations to be transmitted. Flexible conduit shall be spiral interlocked type made of steel strip construction and coated with zinc.

E.2.1.3 Conduit Accessories

E.2.1.3.1 The use of factory made round PVC junction boxes is prohibited. Only cast iron junction boxes of 2-1/4" dia and 2-1/4" long, conforming to BSS 31/latest having nipples to receive PVC pipe with force fit shall be used for ceiling outlets. The wall type junction box shall also be of cast iron having minimum dimensions of 2-1/4" dia and 1-1/4" long. Each junction box shall be provided with one piece cover which shall be fitted on the box with chromium plated screws.

E.2.1.3.2 Conduit accessories such as switch boxes, socket outlet boxes, pull boxes and inspection boxes shall be made of 16 SWG sheet steel having dust tight covers. All boxes shall have required number of conduit entry holes and earth terminals for connecting E.C.C. All the rectangular or square shaped boxes shall have nipples to receive PVC conduit with force fit. All these boxes shall be painted inside and outside with Powder Coating. Shapes and sizes of these boxes shall be determined on each application.

E.2.1.3.3 Manufactured smooth bends shall be used where conduit changes direction. Bending of conduit by heating or otherwise shall be allowed only at special situations with the permission of the Engineer. Use of sharp 90 degree bends and Tees is prohibited. Bends shall have enlarged ends to receive the conduit without any reduction in the internal diameter of the PVC pipe.

E.2.1.3.4 All accessories e.g. boxes, couplings, bends, solid plugs, bushes, reducers, check nuts etc. shall be equal in quality to the specified conduit.

E.2.1.3.5 Where inspection boxes occur in floor slabs a special non-ferrous metal floor trap shall be installed over the box to the satisfaction of the Engineer.

E.2.1.3.6 The use of looping in box shall be allowed in places where floor slab thickness permits 90 degree bends in conduit.

E.2.1.4 Installation Instructions

The Contractor shall furnish all labour and material for the installation of conduit as required.

E.2.1.4.1 Conduit shall be installed concealed in RCC ceiling slabs, columns, walls and floors etc. Recessed conduit shall be laid over the first tier of reinforcement and under the second tier of reinforcement before pouring of concrete. All conduit outlet boxes to be concealed shall be laid firmly flush with the soffit of the slab or beam. The conduit should be tied to the reinforcement firmly so that the alignment is not disturbed by vibrators. All the outlet boxes installed shall be stuffed and their cover plates fixed so as to prevent concrete entering the outlet boxes.

E.2.1.4.2 Under no circumstances shall chassis be made for recessing conduit in the RCC structure after it has been cast without the permission of the Engineer. Where conduits have to be concealed in cement concrete or brick masonry, chassis shall be made with appropriate tools not deeper than required. The conduit shall then be fixed in the chassis with iron hooks before covering it up with at least 20mm thick plaster. Conduit ends pointing upward shall be properly plugged to avoid entry of foreign material.

E.2.1.4.5 The drawings do not show conduit routes and all the planning for arranging conduit routes shall be carried out by the Contractor to the satisfaction of the Engineer.

E.2.1.4.4 The entire conduit system shall be essentially completed before the wire pulling is taken in hand. Each conduit run shall be tested for continuity and obstructions. All obstructions shall be cleared in an approved manner. Water and moisture that has entered any section of the conduit installation must be dried with suitable swabs to the satisfaction of the Engineer.

E.2.1.4.5 Adequate expansion joints shall be provided in all conduit runs passing across the expansion joints in the concrete slabs of the buildings. A typical arrangement is shown on drawing.

E.2.1.4.6 Pull boxes shall be installed in conduit runs at intervals mentioned below to facilitate the pulling length of wires:-

i) Straight runs	- 20 meters
ii) Runs with one 90 degree Bends	- 15 meters
iii) Runs with two 90 degree Bends	- 10 meters

The minimum length of inspection/pull boxes should be four times the cable manufacturer's recommended bending radius of the cable.

- E.2.1.4.7** The conduit shall be terminated at pull boxes, distribution boards and switchboards in an approved manner to the satisfaction of the Engineer without any additional cost to the Owner.
- E.2.1.4.8** Conduit runs between two outlets shall not contain more than two quarter bends or one 90 degree bend.
- E.2.1.4.9** All the free ends of conduit shall be solidly plugged till such time as final and proper terminations are made.
- E.2.1.4.10** All conduits of a system shall be run at least 6" away from the other systems and services where conduit one of system crosses the other it shall do so at right angle i.e. 90 degree.
- E.2.1.4.11** All multiple runs of conduit shall be arranged symmetrically.
- E.2.1.4.12** Exposed runs of conduit where required shall be firmly fixed by means of hospital type saddles, clamps and brackets etc. to the surfaces of walls, columns and ceiling. Rawl plugs or Phil plugs may be used for fixing saddles, clamps and brackets etc. The spacing between two saddles may not be more than 30". The straight runs on walls may be 18" to 24" below the ceiling and in the event of any obstruction due to beams the runs may be routed around them. The conduit shall have a minimum clearance of 6 mm from the surface supporting it. Purpose made special clips and brackets may be required at some situations to support the conduit.
- E.2.1.4.13** No conduit less than 20 mm dia shall be used for point wiring and 25mm dia for circuit wiring. The size of conduit shall however be determined from the number of wires required in the conduit run according to number of wires allowed as per IEE Regulations.
- E.2.1.5 Measurement**
- E.2.1.5.1** All conduit work including all accessories shall be measured on the basis of actual numbers of light points, fan points, call bell points and/or 5A or 15A socket outlet points installed as shown on the drawings. Conduit required for circuit wiring shall be deemed to have been included in the point wiring.
- E.2.1.5.2** For other systems the conduit work shall be on actual measurement basis on the running length installed in feet or meters as the case may be.

SECTION E.2.2 WIRES, CABLES AND CORDS

E.2.2.1 Wires & Cords

The wires & cords for conduit wiring shall be single core, made of stranded copper conductors, PVC insulated, tested to B.S. 6004, 1975. The voltage grade shall be 300/500 volts or 450/750 V unless otherwise specified on drawings and Bill of Quantities. The cables shall be of as approved manufacturer. The size of the wire shall be as follows:-

- i) for light or fan point wiring with 1.5 MM square (or 3/.029) or as specified in the BOQ.
- ii) for light circuit wiring with 2.5 MM square (or 7/.029) or as specified in the BOQ.
- iii) for power plug 15A wiring with 4 MM square (or 7/.036) or as specified in the BOQ.
- iv) for Main to Sub Main wiring 7/.044 (6 MM square), 7/.064 (16 MM square), 19/.044 (25 MM square) or as specified in the BOQ.

E.2.2.2 Installation Instructions

- E.2.2.2.1** The Contractor shall furnish all material and labour to pull in and install wires and cables as required. The Contractor shall also supply, without extra cost, wire accessories e.g. plugs, solder, clamps, supports, bushes, fixing pins, adhesive tapes, connectors, identification tags, straps, filling compound and earthing clips etc. as are required to be furnished for complete wiring installation in accordance with standard practice. The pulling of wires shall be taken in hand only when all conduit system is complete.
- E.2.2.2.2.** The wiring of the installation shall be strictly in accordance with the scheme, cable sizes and circuit details as shown on drawings and specified in E.2.2.1.
- E.2.2.2.3** All wiring shall be continuous between terminations and use of connectors or joints is not be allowed. Spur and Tee connections are strictly prohibited. Looping in system shall be followed throughout.
- E.2.2.2.4** Manufacturers recommended lubricant shall be allowed to facilitate pulling of wires. Use of any kind of oil and soap is prohibited.
- E.2.2.2.5** All wires occupying the same conduit shall be pulled together. Wires and cords at the time of pulling shall not be subjected to a bending radius more than 10 times the overall diameter of cables. Cable manufacturers' recommendation of pulling speed and pulling tension on cables shall govern the pulling operation.
- E.2.2.2.6** Not more than three circuit wire shall be bunched in the same conduit. Wires of two different phases, however, shall not be run or terminated in the same outlet box for single phase wiring of lights, switches and sockets.
- E.2.2.2.7** Molded plastic connectors shall be provided for a joint between light point wiring and light fixture wiring and housed in the outlet box provided for this purpose. The connector after terminations are made shall be wrapped in PVC insulation tape.
- E.2.2.2.8** The quantity and the size of the wire contained in any one conduit shall not be in excess of the , numbers permitted by I.E.E. regulations.
- E.2.2.2.9** All points and circuits wiring shall be solidly earthed by 14 SWG (2.5 mm square) insulated wire to serve as E.C.C. which shall be run inside the conduit.
- E.2.2.2.10** All 5A & 15A sockets shall be wired separately and distinctly from light point wiring.

E.2.2.3 Measurement

Similar to steel conduit - Section E.2.1.5.

SECTION E 2.3 - WIRING ACCESSORIES

E.2.3.1 Switches

E.2.3.1.1 Indoor switches controlling lights and fans shall be single pole, 5A, one or two way, suitable for 250V, 50 Hz. The body of the switches shall be made of molded plastic, one, two, three or four gang with integral built in molded plastic face plate suitable for fixing on a sheet steel outlet box. The switch contacts shall be silver alloy tipped and these shall operate with inspection. The switches shall be Piano type, ivory white in color and made by approved manufacturer. The switches shall comply with BSS 3676/1969. Dimmer switches shall conform to BSS 800.

E.2.3.1.2 Weather proof switches on lighting circuits shall be rotary type with quick make quick break action rated 5 Amps, 250 V, 50 Hz.

E.2.3.2 Switch Socket Outlet Units

E.2.3.2.1 Switch and socket units shall be single, pole, 3 pin rated 5A or 15A, 250V, 50 Hz. These shall be moulded plastic type with ivory white integral built-in face plate. Each socket shall have its control switch by the side of it on a common face plate. Thus the complete unit specified in BOQ shall be as switch and a socket outlet unit. The switch socket outlet unit shall comply with BSS 546 and BSS 5733 or BSS 3052. Bells/Buzzers and bell bushes shall be suitable for operation on 230 Volts and quality acceptable to the Engineer.

E.2.3.2.2 Weather proof switch units shall have a cast iron outlet box with threaded conduit entry holes or nipples rubber gasket and a spring loaded sheet steel cover.

E.2.3.2.3 Ceiling roses shall conform to BSS 67/1969. Lamp batten holders shall conform to BSS 5042 Part-1.

E.2.3.3 Installation Instructions

All the switches and switch socket outlet units shall be installed on 16 SWG thick sheet steel outlet boxes of appropriate sizes having 5mm thick ivory white Perspex face plate fixed recessed in walls or columns. All sheet steel boxes shall have conduit entry nipples and earth terminals for connecting 14 SWG insulated earth continuity copper conductors.

E.2.3.4 Measurement

E.2.3.4.1 The number of units installed shall be taken as the basis of measurement.

SECTION E.2.4 POINT WIRING, CIRCUIT WIRING AND SOCKET OUTLET WIRING

E.2.4.1 General

The work included under this Section consists of furnishing all labour, material, services and skilled supervision necessary for the construction, erection, installation and connection of all circuits and equipment specified herein or shown on the drawings and/or normally required for an installation of this type including but not limited to testing of the installation and its handing over to the Owners. The extent of work specified herein and/or shown on the drawings represent the minimum requirements. The installation on the whole should conform to the best norm of workmanship and shall be accomplished by workmen, licensed and skilled in this type of work.

E.2.4.2 Measurement

E.2.4.2.1 Point Wiring

For the purpose of measurement of light/fan point wiring the following work shall be deemed to constitute the work of a point wiring :-

- a) Providing and fixing conduit from a switch to wall/ceiling outlet of fan/fixture including final sub-circuit conduit from distribution board to the switch as described in Section E.2.1.
- b) Providing and pulling of wires from switch to fan/fixture outlet including providing and pulling of final sub-circuit wiring in the conduit laid as in (a) above and as described in Section E.2.2.
- c) Providing & pulling ECC as in clause E.2.2.9.

E.2.4.2.2 Socket Outlet Wiring

- 1) For 5A sockets on the light switch board and also away from the board the basis of the measurement shall be the same as in Section E.2.4.2.1.
- 2) For 15A sockets outlets the work shall comprise as under :-
 - a) Providing and fixing conduit from distribution board to the socket outlet as described in Section E.2.1.
 - b) Providing and pulling of wires in the conduit as in (a) above as described in Section E.2.2.
 - c) Providing and pulling ECC as in clause E.2.2.9.

E.2.4.2.3 Call Bell Point Wiring

This shall be identical to Section E.2.4.1 i.e. wiring for light points.

SECTION - E.2.6 - LIGHT FIXTURES

E.2.6.1 General

Light fixture schedule is provided in the drawings alongwith catalogue numbers of the manufacturers which are meant to serve as illustrations of the types of fixtures required for various applications. The Contractor shall be required to submit samples of each and every light fixture for the approval of the Engineer, before commencing with mass production of the fixtures. The Contractor should be prepared to carry out any number of modifications and improvements in the submitted sample free of cost until a finally acceptable sample is produced. Mass production shall be taken in hand only when a finished and modified sample has been produced and approved in writing by the Engineer. The Contractor has the option to offer acceptable equivalent of the specified light fixtures.

E.2.6.2 Incandescent Light Fixtures

1. The glass globes/shades/diffusers of the incandescent light fixtures shall be first class quality glass free from any air bubbles or voids. The glass shall generally be of opal white colour unless otherwise specified. The shape of the glass may be spherical, hemispherical, flattened bottom or tablet shaped as required.

2. Surface mounted fixtures shall have white stove enameled sheet steel body. It may also be satin brass or aluminum anodized finish as required. The fixing holes shall match the outlet box. Wall bracket light fixtures shall have back plates with matching holes of the outlet box and decorative finish as required.
3. All light fixtures shall have bi-pin brass lamp holders and Philips GLS lamps, to BSS 161/latest clear or frosted and having a minimum useful life of 1000 hours.

E.2.6.3 Fluorescent Light Fixtures

1. All the light fixtures shall have lamps and electronic ballasts of the wattage specified. The fluorescent lamp shall be either 2 ft-20 watts or 4 ft-40 watts and the colour shall generally be day light, cool day light and/or warm white in the order of preference or as mentioned specifically. The fluorescent lamps shall be Philips or Equivalent or defined in BOQ to BSS 1853 but having a minimum useful life of 5000 hours. The new generation of 26mm dia 18 watts and 36 watts energy efficient lamps shall be preferred.
2. The ballast shall be totally enclosed electronic type suitable for operation on 220 V, 50 Hz, single phase supply, A wiring diagram, wattage, voltage and current ratings shall be printed on the body of the ballast. The power loss shall not more than 10 watts for 40 watts ballast. The ballast shall be noiseless in operation without any whistling sound. The manufacturer shall be called upon to guarantee a trouble free life of 3 years, effective from the date of Completion Certificate.
3. All lights fixtures shall be provided with p.f. improvement capacitors. The following capacitor combinations shall be used/wired on 'du' circuits. For 2x40 watts fixture 3.7 mfd capacitor 380 volts. For 4x20 watts fixture 3.7 mfd capacitor 380 volts. Other combinations on single circuit shall be as under :-
For 1x40 watts fixture 4.5 mfd capacitor 250 V
For 2x20 watts fixture 4.5 mfd capacitor 250 V
For 1x20 watts fixture 3.7 mfd capacitor 250 V
4. The lamp holder shall be lock-in rotary type.
5. The starters shall have radio-interference suppressers.
6. The internal wiring of the light fixture shall be carried out at manufacturers factory with heat resistance wires of size not less than 1.5 mm square.
7. The louvers of light fixtures shall be made of anodized aluminum and/or moulded plastic. The diffusers shall be made of acrylic perspex.
8. The body of the light fixture shall be white or grey stove enamel as required. The industrial reflector shall have white stove enamel finish inside and grey/green stove enamel finish outside. Appropriate sized bushed entry holes, and fixing holes shall be provided. The thickness of the sheet steel used in the fabrication of the body and reflector shall not be less than 20 gauge.
9. Pendant type of fixtures shall have 2 Nos 1/2" dia chromium plated pendant tubes for suspension or as per detail shown on drawings.

E.2.6.4 Installation Instructions

1. The light fitting shall be installed according to manufacturer's recommendations or as approved by the Engineer.
2. Flexible connecting wires from outlet box to the fixture shall be provided by the Contractor; connector made of porcelain or thermoplastic material shall be provided and installed in the outlet boxes for connecting flexible wires to the point wires.
3. Outlet boxes or any openings in the ceilings or walls shall be covered with appropriately fabricated accessories to provide an architectural entity to conceal them.
4. Rawl plugs or nylon plugs with wood screws shall be use for fixing purposes.
5. Para E.2.2.2.9 is applicable to all light fixtures.

E.2.6.5 Measurement

Actual numbers of units installed shall be taken as the basis for measurement.

SECTION E.2.7 - POWER CABLES

E.2.7.1 General

Power cables conforming to these specifications, described in the B.O.Q. and as shown on drawings shall be supplied, tested and installed. The cables shall be manufactured as specified hereunder.

E.2.7.2 11 KV Power Cables

E.2.7.2.1 All XLPE cables shall be manufactured to I.E.S. standard 502 or BSS-5467.

E.2.7.2.2 The XLPE cables shall be provided with extruded semi-conducting conductor screen over stranded circular copper conductors before XLPE insulation is provided. On each core of conductor another layer of extruded semi-conducting core screen and copper tape screen are provided. The number of cores required then shall be put together and the antiseptis filled with non-hygroscopic fiber filler and binding tape. The core is extruded with another PVC bedding.

E.2.7.2.3 Galvanized steel armour is provided underneath an overall PVC sheath.

E.2.7.2.4 11 KV XLPE cables shall be manufactured by as approved Manufacturer.

E.2.7.3 L.T. Cables

E.2.7.3.1 The Low Tension cables shall be manufactured to the requirements of B.S. 2004, B.S. 6004, B.S.3346, B.S.6346 latest or VDE 0271 AND RATED AT 250/400 and 600/1000 volts as the case may be. The cables for street lighting shall be with split con-centric neutral to B.S.S. 4553/latest. The cables shall be manufactured by as approved manufacturer.

E.2.7.3.2 The conductors shall be annealed copper conductors, single or stranded, circular or shaped as the case may be, to B.S.S. 6360/69.

- E.2.7.3.3** The Conductors specified for use in the cables shall be of at least 98% IASC conductivity.
- E.2.7.3.4** The reference temperature for the purpose of determining the standard resistance of the conductors shall be 20 degree centigrade.
- E.2.7.3.5** The conductors shall be insulated with poly-vinyl- chloride insulation. The minimum thickness of the insulation shall be in conformity with the specifications to which it is manufactured.
- E.2.7.3.6** On all multi-core cables proper markings for core identification shall be provided to B.S. Specifications.
- E.2.7.3.7** Power cables shall be multi-core cables, insulated and sheathed, armored or unarmored as required.
- E.2.7.3.8** Various conductors forming the cables shall be laid together and voids shall be filled with soft plastic or fibrous materials so as to give a circular shape to the cable.
- E.2.7.3.9** A tough PVC shall be extruded over the cable so as to cover the insulated conductors and fillers.
- E.2.7.3.10** Where armoring is required, a soft PVC jacket shall be provided over the laid up cable. Steel wire armoring shall be applied on a tough PVC sheathed extruded over the cable so as to cover the insulated conductors, fillers, jacket and armoring.
- E.2.7.3.11** Complete identification of the cable together with Owner's identification markings if required shall be embossed on the final over sheath of the cable at every meter length.
- E.2.7.3.12** The following tests shall be carried out by the manufacturers :-
- i) Dielectric Strength Test
 - ii) Instantaneous and longtime break down strength test.
 - iii) Temperature rise test.
 - v) High voltage test.
- E.2.7.3.13** Test certificates covering all these tests shall accompany the cables supplied by the Contractor.
- E.2.7.3.14** after carrying out the tests as laid down in these specifications both ends of the cables shall be sealed at the manufacturer's works.
- E.2.7.3.15** The cables shall be delivered wound over strong drums of suitable dimensions. The cables ends shall be fastened to the drums and completely protected in suitable manner to protect any injury to the cables during transportation and handling. The direction of rolling shall be clearly marked with bold arrows on both faces of the drums.
- E.2.3.7.16** The Owner may require the Engineer to witness the tests as specified herein and the Contractor shall make necessary arrangements for the presence of the Engineer on such tests and obtain their signatures in testimony thereof without any cost to the Owner.
- E.2.7.4 Cables Terminations**
- E.2.7.4.1** All PVC power cables shall be terminated with suitable tinned brass cable glands for securing the armour wires and incorporating a packing ring for exclusion of water and moisture. The cables shall be secured at required spacing by means of cleats fixed to walls or roofs or hangers and where multiple runs occur perforated metal tray made of heavy gauge galvanized steel shall be used.
- E.2.7.5 Cable Markers**
- E.2.7.5.1** For underground installation cable position markers shall be sited in the ground where cables change direction and at 30 meter intervals along straight runs of the cables. Markers shall also be provided to locate the position of joints. Cable markers shall be made of cast iron. Any one of the following words shall be embossed/engraved for the identification of cable routes.
- | | |
|-------|---------------|
| 11000 | V cable |
| 440 | V cable |
| 11000 | V cable joint |
| 440 | V cable joint |
- The markers shall comprise of a cast iron circular disc of 115 mm dia and 10 mm thick to which an angle iron 25x3 mm bar 710 mm long shall be riveted at one end. The end of the bar shall be fork-opened up to a length of 75 mm. This end shall be embedded in a cement concrete block of ratio 1:3:6 to a length, of 180 mm. The concrete block shall have a shape of truncated pyramid with base dimensions of 305x305 mm and top dimensions of 152x152 mm and a vertical height of 200 mm. The cable marker shall be buried in the ground such that its total height above ground level is 267 mm.
- E.2.7.6 Cable Joints**
- E.2.7.6.1** The Contractor shall be in possession of a cable jointing kit and all termination shall be made by a bona-fide and experienced cable joiner. All cable termination boxes kits and glands shall be of recognized makes and complete with claw clamps, ferrules, lugs, tapes, solders and jointing compounds.
- E.2.7.7 Installation Instructions**
- E.2.7.7.1** The Contractor shall be under obligations to provide all labour, material and accessories for the installation of cables shown on drawings and listed in the BOQ conforming to the specifications in this section. The Contractor shall provide, without any extra cost, all material for termination of cables such lugs, solders, clamps, supports, ferrules, bushes, fluxes, tapes, fixing pins, identification tags, earthing clips, straps for a complete terminal jointing operation in accordance with the best modern practice.
- E.2.7.7.2** For underground cable installation the depth of digging the trench shall be such that the top surface of the cable shall not be less than 900mm and more than 1100 mm from the finished ground level. It will be Contractors responsibility to obtain true trench levels.

- E.2.7.7.3** Cable routes indicated on the drawings shall be followed unless otherwise specified or agreed to by the Engineer. Where change in direction of the cable is necessitated, the bending radius of the cable shall not be less than the diameter of the cable drum or 12 times the diameter of the cable whichever is greater.
- E.2.7.7.4** At all road crossings the cables shall pass through 100/150 mm dia PVC pipes shrouded in cast concrete, the mouths of which shall be sealed with cable bitumen compound of approved quality after drawing the cable. The road cuts shall be first filled with mud and 50mm size ballast upto 182 mm level below the road surface and after ramming it properly 150 mm thick layer of cement concrete 1:3:6 shall be laid over it.
- E.2.7.7.5** The cushion of sand to be provided in the trench before laying the cable shall not be less than 75mm and after laying the cable 150 mm. The total depth of cushion of sand shall be not less than 225 mm. Over the final layer of sand, cable marking tiles/bricks or concrete masonry blocks of adequate strength 2" thick and 300mmx200mm in size shall be provided to the satisfaction of the Engineer. The rest of the trench shall be back-filled with earth in 150mm layers and rammed properly before dressing.
- E.2.7.7.6** All trenches and holes dug for laying the cables shall not be left open and unprotected for any length of time without completing the job and back-filling it to the satisfaction of the Engineer. Where trenches are left open due to some unavoidable reasons the Contractor shall exhibit suitable danger signals such as banners, red flags and red lamps etc. etc.
- E.2.7.7.7** All cables shall always be lead out or lead into the ground through 2.5 meter long G.I. pipe of 75 mm dia or suitable size as approved by the Engineer. The length of the pipe in the ground shall be 600mm. The pipe should be attached to the poles with approved clamps.
- E.2.7.7.8** Markers of approved design and inscription shall be installed as specified. E.2.7.7.9 For installation of cable in perforated metal trays, the cable shall be tied or bunched properly in an approved manner. Similarly for installation of cables on cleats or raceways approval of the Engineer shall be obtained.

E.2.7.8 Measurement

For the purposes of measurement this item shall be treated as actual lengths of cables installed in meters at site.

SECTION E.2.8 - MAIN L.T. SWITCHBOARD

E.2.8.1 General

The L.T. switchboard shall be indoor type, free standing, free supporting, floor mounted, totally enclosed, sheet steel clad, dust and vermin proof, completely wired, factory assembled and suitable for operation on 3 phase 4 wire system, 415 V, 50 Hz, AC supply. The board shall be suitable for installation back to the wall and capable of front attendance. The switchboard shall comprise of multi-panels suitable for housing, air circuit breakers, moulded case breakers or load break switches as shown on the drawings and as listed in the schedule of quantities. The switch board shall be designed to suit service conditions and ensure security and safety during operation, inspection, operation, cleaning and maintenance. The switch board shall be designed and tested to IEC recommendations. Each panel shall withstand strain of 2000 volts insulation level for one minute power frequency test. The switchboard shall comprise of the following main components and each removable component of the same rating shall be physically and electrically interchangeable. Switchboard to British Electricity Standard 41-5 are also acceptable. The switch board shall be as approved manufacturer.

E.2.8.2 Air Circuit Breakers

- E.2.8.2.1** The Air Circuit breaker shall be triple pole of specified rating, fixed type, trip free, spring charged, quick make, quick break manually operated mechanism and visual ON/OFF position indicator. The circuit breaker shall be suitable for continuous duty for the rated current for indefinite period of time under service conditions. The circuit breaker shall have 50/65 KA (or as specified) breaking capacity and shall be capable of the following make/break operations:-

- Electrical - 500 cycles
- Mechanical - 8000 cycles

The A.C.B. shall conform to BS 4752/1977. The contacts of the A.C.B. shall be heavy duty, spring charged and silver plated. Replaceable arcing contacts and arc chutes shall be provided. The operating handles if made of metal shall be either earthed or additionally insulated to withstand full insulation voltage. A certified copy of full type tests carried out by an independent agency on identical breakers shall be acceptable in lieu of the following type and routine tests :-

- i) Making capacity, breaking capacity and short time current tests.
- ii) Mechanical and electrical life endurance tests.
- iii) Temperature rise test.
- iv) Power frequency with stand test.
- v) Milli volt drop test.

However all other routine tests shall be witnessed by the Engineer at no additional cost to the Owner.

- E.2.8.2.2** The relays shall have three elements, two for the over current and one for the earth fault. These shall be inverse over-current definite minimum time induction type with inverse characteristics. The relays shall be AC operated and provided with time and current setting adjustment of suitable range. The relays shall be equipped with instantaneous elements which have infinity setting or lock out position to make the instantaneous element in operation. The rated error of all the relays shall not be more than 7.5% at full setting. The relay characteristics shall not change plus and minus 7.5% with changes in ambient temperature of + 10% from the reference temperature of 25 degree centigrade and with changes in the frequency of plus 2% to - 6% from the rated frequency. Certified tests carried out by an independent agency shall be supplied in lieu of the following type tests :-

- i) Limit of error test.

- ii) Temperature rise test.
- iii) Overload test.
- iv) Contact rating test.
- v) Mechanical durability test.
- vi) Variation of characteristics with ambient conditions and frequency.

The relays shall conform to BSS 142/latest.

E.2.8.2.3 Three single pole, resin filled current transformers, 15VA burden, suitable for metering and manufactured and tested to IEC publication 185 shall be provided. The standard accuracy class shall be 0.5%. The rated short time thermal current rating and the rated dynamic peak current rating shall be according to IEC recommendations. The following type tests shall be carried out on C.T's :-

- i) Short time current test - Clause 19
- ii) Temperature rise test - Clause 20
- iii) Accuracy test - Clause 29
- iv) Instrument Security current test - Clause 31

The following routine tests shall be carried out on C.T's :-

- i) Verification of terminal marking - Clause 14
- ii) Power frequency test at Primary & Secondary windings - Clause 16
- iii) Over-voltage inter-turn test - Clause 17

C.T's conforming to B.S. 3938/1973 are also acceptable.

E.2.8.2.4 The following instruments shall be provided unless otherwise specified :-

- 1- KWH meter
- 1- Voltmeter 0-500 volts
- 1- Voltmeter phase selector switch
- 1- Ammeter commensurate with rating of ACB
- 1- Ammeter phase selector switch

All the instruments shall be flush mounted and back connected in a transparent dust proof cover with 144x144mm (6"x6") dial which shall have prominent black graduations on white surface. The instruments shall be manufactured and tested in accordance with IEC Publications 51 or B.S.89 Part 1/1970.

E.2.8.3 Moulded Case Circuit Breakers

The moulded case circuit breakers shall be triple pole and of the rating specified in the schedule of quantities and/or shown on drawings. The M.C.C.B shall be of fixed type, having trip free, manually operated mechanism and ON/OFF/Trip position indicators. The MCCBS shall comprise of adjustable hydraulic magnetic releases for overload protection and instantaneous adjustable electro-magnetic releases for short circuit protection. The tripping devices shall have related time current characteristics so that positive discrimination and selective tripping is obtained assuring the tripping under fault conditions of only the breaker in the circuit ahead of the fault location. The MCCB shall have a rupturing capacity of 35 KA (or as specified) and shall be and manufactured tested to IEC Publication 157-1 Part 1 or BS 4752/1977 or BSS 3871 Parts I & II. The MCCBS manufactured by as approved manufacturer. E.2.8.4 Load Break Switches The load break switches shall be on load type having quick make and quick break mechanism with spring loaded handles and ON/OFF visual indications. The load break switches shall be designed for continuous operation on rated current, rated voltage and rated frequency to BSS 861 (Part-2)/1972. The contacts shall be heavy duty made of silver plated copper having 98% I.A.S.C. conductivity. When the operating mechanism is in "OFF" position, the fuses shall be completely disconnected. If the handle is metallic it shall be properly earthed. Arching chambers with replaceable arching chutes shall be provided. The following type and routine tests shall be conducted on the load break switches :-

- a) Type Tests
 - i) Temperature rise test
 - ii) Mechanical endurance test
 - iii) Making/breaking capacity test
 - iv) Short time current test
- b) Routing Test
 - High Voltage tests

E.2.8.5 HRC Fuses

The HRC fuses shall be manufactured and tested to BSS 88/1967 (Part 1) for category of duty AC 33 (or as specified). A supplement of 100% spare fuses of each size shall be supplied with the Switch-board. The following tests shall be conducted on fuses :-

- i) Time-current characteristic
- ii) Temperature rise test
- iii) Breaking capacity tests

The fuse carriers and bases shall be made from moulded phenolic compound and or porcelain.

E.2.8.6 Bus Bars Adn Connections

A set of four bus bars, three for phases and one for neutral, made of copper having 98% IASC conductivity shall be provided. The bus bars in panels and chambers shall be tin plated, air insulated having minimum clearance of 50mm between phase to phase and 25mm between phase to earth. The neutral bar shall be of the same section. All the bus bars shall be mounted on insulators at suitable intervals and should be extensible on both ends. The marking and

arrangement of bus bars, main connections and small wiring shall conform to BS 158/1961. Bus bars and bus bar connections shall conform to BS 159/1957.

E.2.8.7 Enclosures

The enclosures shall be fabricated from 3mm thick high grade sheet steel and shall be designed to house all the live parts which shall be accessible through front doors. The enclosure shall be tropical in design completely dust and vermin proof and liquid repellent, with special regard to danger of flash over both in service and in isolated position. Hinged lockable doors shall be provided on the front and bolted plates at the rear. Adequate air circulation by means of vent covered with suitable metal gauze shall be provided in the enclosures. All exterior and interior surfaces of the enclosure shall be thoroughly cleaned and freed of dust, rust and greasy matter. The enclosures shall be given three coats of paint. The primer shall be Zinc Chromate and/or iron oxide. The second and third coats shall be top quality battleship grey enamel. Enclosure for each panel shall be provided with designation labels as directed by the Engineer.

E.2.8.8 Earthing

The Switchboard shall be effectively earthed by means of a Copper Strip of 25mm x 3mm (1"x1/8") cross-section bolted to connections near the bottom of the Switchboard.

E.2.8.9 Accessories

Designation labels, lifting lugs, foundation bolts, interconnecting nuts bolts, and washers, thimbles, lugs, leveling shims cable glands and/or cable end boxes for all the sizes of incoming and outgoing cable shall be supplied with the Switchboard.

E.2.8.10 Testing

The following tests shall be conducted on each completed switchboard:-

- a) Type Tests
 - i) Temperature rise test
 - ii) Mechanical endurance test
 - iii) Making/Breaking Capacity test
- b) Routine Test
 - High Voltage test

The Switchboard shall be tested to British/Electricity Council Standard 41-5 and manufactured by M/s. Siemens (Pakistan) or AEG (Pakistan) or approved equivalent. Preference shall however, be given to Switchboards fabricated from all components manufactured by only one manufacturer.

E.2.8.11 Installation Instructions

All labour, equipment, tools and plant required to complete the installation shall be provided by the Contractor. The Switchboard shall be fixed firmly on the floor in perfect line, plumb and level position. All incoming and outgoing cable connections shall be made including Earth connections.

E.2.8.12 Measurement

For the purpose of measurement each L.T. Switchboard shall be treated as a lump sum job.

E.2.9 - SUB-MAIN BOARDS

The Sub-main boards shall be similar to the Main L.T. Board and the Components in its fabrication may differ and shall comprise of the components as shown on drawings and as described or listed in the Schedule of quantities. The rupturing capacity of the each component for Sub Main Boards shall be as under :-

- 1) Air circuit breakers -
- 2) Moulded case circuit breaker -
- 3) Load break switches -
- 4) HRC fuses category -

All other details and specifications as in Section E.2.8 shall be applicable to this section.

E.2.9.1 Measurement

For the purpose of measurement each Sub-Main Board shall be treated as a lump sum job

SECTION E.2.10 - DISTRIBUTION BOARDS

E.2.10.1 General

The distribution boards shall be either free standing, cubicle type or wall mounting type suitable for surface and/or recessed mounting. Each distribution board (d.b.) shall be tropical in design, fully dust and vermin proof and liquid repellent. The cabinet housing the main components shall be fabricated from mild steel sheets 16 SWG thick and reinforced with structural steel members welded to it. Front access, mechanically locked and hinged doors, fully gasketed, having one or two leafs depending upon the size of the cabinet shall be provided on each Cabinet. All open able parts shall be provided with gaskets or lining and screwed to the main body with chromium plated screws. The cabinets after fabrication shall be thoroughly cleaned completely derusted and degreased before applying one coat of zinc or leadbased primer and then two coats of top quality synthetic emulsion or stove enamel paint in battleship grey colour. All exposed parts of the dbs shall be covered with 5mm thick bakelite sheet. A load distribution chart shall be provided in each db showing the areas fed by each circuit and a suitably sized pocket inside the front door shall be provided for the purpose. Each db shall be delivered complete with all instruments accessories, rating plates, designations, as approved by the Engineer.

Suitable cable entry glands shall be provided as required for floor mounted boards on the incoming cables but for outgoing cables and/or wall mounted boards exact number of conduit entry holes as are required shall be provided with male brass bushes. The bushes shall be tin plated and fully shrouded or housed in gasketed compartments.

E.2.10.2 Components

The Main components e.g. Moulded case circuit breakers, load break switches, HRC fuses and instruments that are required for db's as shown on drawings and as described in schedule of quantities shall be the same as described in Section E.2.8. However miniature circuit breakers (MCBs) used in db's are briefly described hereunder:-

E.2.10.3 MCBs

The incoming shall have triple pole mcb's suitable for use on 415V 50 Hz, AC and the outgoing mcbs shall be single pole or single phase for use on 220V, 50Hz, AC. The ratings are as shown in drawings and/or described in the Schedule of Quantities.

The mcbs shall be moulded case type having hydraulic magnetic short circuit releases, contacts, operating mechanism and arcing chambers. The mcbs shall be manufactured and tested to BSS 3871/1966, and shall have a rupturing capacity of 7.5 KA. The final circuit mcb, on the outgoing, shall however be rated 5KA. The mcb's manufactured by Terasaki Jpan or Fuji Japan or Marlin & Gerin France or Mitsubishi Japan or approved equivalent are acceptable. The Distribution Boards shall be manufactured by as approved manufacturer.

E.2.10.4 Installation Instructions

All labour, equipment, tools, plant and accessories required to complete the installation shall be provided by the Contractor. The distribution board shall be fixed as required in perfect line and plumb. All incoming and outgoing cables shall be terminated properly. All earth terminations shall be made on the neutral block.

E.2.10.5 Testing

All DBs shall be tested at manufacturer's works DBs tests shall be witnessed by the Engineer without incurring any additional expense to the Owner.

E.2.10.6 Measurement

Each distribution board for the purpose of measurement shall be treated as a lump sum job.

PLUMBING WORKS

G-1 GENERAL

The stipulated therein, the direction as given below shall invariably be read with Section of the Special Provisions of the Contract.

The materials used and workmanship shall be of highest quality and grade and shall conform to the latest specifications of British Standards and Codes of Practice " Water Supply " Sanitary Pipe Work" " Building Drainage " Surface Water and Sub-Soil Drainage" and applicable to details and work indicated on the Drawings and Bill of Quantities or otherwise approved.

G-2 DRAWINGS AND INFORMATION REQUIRED

- a) The Contractor shall submit shop drawings for the entire installation including installation details for all items required or asked for approval of the Consultants.
- b) Approval by the Consultants of shop drawing for any material, apparatus, devices and layout, shall not relieve the Contractor from the responsibility of furnishing same of proper dimension, size, quantity and all performance characteristic to efficiently perform the requirements and intent of the Contract Documents. Such approval shall not relieve the Contractor from responsibility for Eros of any sort in the shop drawing.
- c) If the shop drawings deviate from the Contract Documents the Contractor shall advise the Consultants of the deviations in writing accompanying the shop drawings including the reasons for the deviations. At the start of the Project the Contractor shall periodically and thereafter submit to the Consultants a list of all shop drawings which will be submitted in the course of the project. The list shall show the disposition of each item including date of submission approval etc. The list shall be kept upto date through the entire course of construction.

G-3 CLEANING AND PROTECTION

- a) The Contractor shall be responsible for his work until its completion and final acceptance, and shall replace any of the same which may be damaged, lost or stolen without any additional cost to the Owner.
- b) The openings left in floor for passage of lines of soil waste, vent and supply pipes shall be covered and protected.
- c) The pipes shall be protected with suitable covering as soon as set. All open ends of pipes shall be closed by a plug fitting to prevent obstruction and damage. The use of new permanent water closets and other new plumbing fixtures during the progress of work is prohibited.
- d) As soon as installed, all metal fixtures trimmings shall be thoroughly converted by this Contractor with non-corrosive grease which shall be maintained until all construction work is completed.
- e) Upon the completion of the work, all fixtures and trimmings shall be thoroughly cleaned and polished and left in first class condition.
- f) Prior to delivering the plant to the Owner the Contractor shall thoroughly clean all equipment fixtures, fittings etc.
- g) Before final connections are made and before operation of equipment and piping, all piping interior shall be thoroughly blow out, or washed out at least twice in a manner as directed by the Consultants remove all accumulation of dirt chips or other deleterious materials. Make all temporary connections and furnish all appliance required for the purpose of cleaning at no extra expense to the Owner.

- h) Before erection, all pipes, tubing, valves and fittings shall be thoroughly cleaned of oil, grease or other combustible materials by washing in a hot solution of sodium carbonate or tri sodium phosphate mixed in the proportions of one pound to three gallons of water.

G-5 RECORD DRAWING

- a) During construction the Contractor shall keep an accurate record of all deviations between the work as shown on the Contract Drawings and that which is actually installed.
- b) The Contractor shall secure from the Consultants after approval of his Shop Drawings a complete set of drawings and note changes thereon in ink.
- c) The Contractor shall make a complete record of all changes and revisions in the original design which exist in the completed work. The cost of furnishing above prints and preparing these for record "shall be deemed to be included in the tendered cost and its effect spread over other items of work, and as such item shall not be a subject to payment" When all revisions showing the work as finally installed are made, the corrected Original Transparencies shall be submitted to the Consultants for review and delivered to the Engineer before final payment for the completed work will be made.

G-5 OPERATING AND MAINTENANCE INSTRUCTIONS

Three sets of operating and maintenance instruction covering completely the operation and maintenance of all plumbing equipment, controls, heaters, pumps and the like shall be furnished to the Owners.

G-6 INSPECTION AND TESTING OF WATER MAINS AND WATER SUPPLY SYSTEMS

Water Mains

The Main should be tested in sections as the work of laying proceeds and joints should be left exposed for inspection during testing. After completion of each section, the main should be carefully and slowly charged with water so that all air is expelled, allowed to stand full of water for 1-2 days if possible and then tested under pressure. The test pressure should be 90M head or the maximum working pressure plus 50%, whichever is the greater.

The pressure should be applied by means of a manually operated test pump or, in case of long mains or mains of large diameter, by a power-driven test pump provided that the pump is not left unattended. Precaution must always be taken to see that in test pressure is not exceeded. Pressure gauges must be accurate and if necessary should be recalibrated before the test.

After the pump has been stopped,, the test pressure should be maintained as long as is necessary to inspect the whole of the pipe work under test and in any event not less than half-an-hour. Open ends of mains should be temporarily closed for testing under moderate pressure by fitting watertight expanding plugs. The end of the main and any test plug must be well secured to resist the end thrust of the water pressure in the main, i.e. maximum test pressure x cross sectional area of pipe. If the section of main terminates with a sluice valve, the wedge of the valve should never be used to retain the water because this might lead to permanent distortion of the working parts of the valve. Instead the valve should be fitted with a blank flange or socket plug and the valve left in the open position whilst testing. End support should be provided as explained previously.

Cold Water Systems

When the installations are complete they should be slowly and carefully charged with water, allowing all air to escape thus avoiding shock or water hammer. The system should be inspected under working conditions of pressure and flow and when all draw off taps are closed, should be absolutely watertight. Each draw-off tap should be opened and tested for rate of flow. Certain specifying authorities may require pressure testing of internal pipe work in which case, systems should be tested in accordance with the pressure test previously described. In such cases it may be necessary to isolate items of equipment from the pressure test if they are not capable of withstanding the test pressure. Where these items are removed, blanking flanges or plugs must be used or a make-up piece of pipe work installed temporarily. All piping, fitting and appliances should be inspected and checked for satisfactory support and protection from physical damage corrosion and frost. Because of the possibility of damage in transit, it is always advisable to re-test cisterns, tanks and cylinders for water-tightness on arrival at site and before fixing.

Hot Water systems

Hot water systems should be thoroughly flushed out and then tested in the same manner as described for cold water systems. Where thermal insulation is used, the hydraulic test should be made before the insulation work is completed and whilst all joints are exposed.

Where a pressure test is employed, boiler and calorifier relief valves should be removed and these valves should be tested later. The test pressure should be one and half times the normal working pressure and this should be maintained for thirty minutes after making good any leaks.

It is necessary to carry out the hydraulic pressure test on sections of pipe work prior to completion of the whole installation where these are fixed in ducts, chases, trenches, etc. and are concealed from view. If rectification of faulty materials of workmanship on such sections is likely to involve disturbance to finished structural features, the test pressure should be twice the normal working pressure.

Sterilization of Cold Water Systems

The whole of the system should be sterilized to eliminate possible traces of bacteria. Sterilization of public water mains is carried out by the Water Authority who may also carry out the sterilization of new private mains. Where this is not standard practice, the plumbing contractor should carry out the sterilizing process as described below. After cleaning the cistern of all debris, the cistern and pipe work should be filled with water and the whole thoroughly flushed out. The system should be then be filled with water a second time, but as the cistern is filling, a sterilizing chemical containing

chlorine should be added to ensure thorough mixing of the chemical and water. The dose should be such as to give 50 parts of chlorine to one million parts of water. If ordinary bleaching powder is used, the proportion should be 150g of powder to 1000 litres of water, the powder first being mixed with water to creamy consistency before being added. Proprietary brands of sterilizing chemicals should be added in the proportions as instructed by the manufacturers.

After filling the system, the incoming water supply should be shut-off and each tap on the distributing pipes opened successively, starting with that nearest the cistern. As the water which issues from each tap begins to smell of chlorine, the tap should be closed. The cistern should then be filled again to water-line with water to which has been added the correct dose of chemical.

The whole system should be allowed to stand charged with treated water for a period of at least 3 hours, after which a test should be made by smell for residual chlorine. If none is found, the sterilisation should be repeated. Before any water is used for domestic purposes, the whole system must be emptied and thoroughly flushed out with clean water.

SECTION - 1 WATER SUPPLY WORK

1.1 DESCRIPTION

Work in this section shall include supply and installation of all the G.I. pipe work upto 6" (150 mm) including all materials, plants, equipment, labour etc. to complete the work in close conformity with the plans and in accordance with the provisions included herein.

1.2 MATERIAL REQUIREMENTS

All un-installed pipes and fittings used in the building work whether hidden in block/concrete work or running underground shall be of Galvanized Iron hot dipped in bitumen, wrapped around with bituminous hessian with final two coats of brush applied bitumen.

It shall be ensured that the fittings shall be tested by jointing at least 5% of them to straight pipes in pipe vices with sufficient pressure, to the satisfaction of the Engineer. Defective fittings invariably crack on application of the pressure. The fittings shall also be examined to detect blisters and minor cracks. The G.I. pipe, fittings and specials shall conform to the following specifications:-

- a) G.I. Pipe
 - o BS-1387: Class-M
 - o Test Pressure = 700 psi
- b) Malleable Iron Iron (Galvanized Fittings (i.e. coupling, elbows, Tees etc.) for G.I. Pipes 2-1/2" and below shall be of at least same thickness and quality as G.I. Pipe.
- c) Cast Iron threaded flanges for joining G.I. Pipe of dia 3" and above.
 - o BS-10: 1962, Table D.
- d) Cast Iron flanged fittings, for G.I. pipe 3" and above.
 - o BS-2035, 1953: Class-B.
 - o Working Pressure = 400 ft. of water.
- e) Expansion Joints in G.I. Pipes.
Adequate provision for expansion shall be provided on all pipe work as shown on the drawings. The Contractor shall obtain the Engineer's approval for the materials being used for a particular expansion joint. Expansion loop for Horizontal G.I. Pipe of dia 3" or below.
- f) Cast Iron Sluice Valve (size 3" and above)
 - o Cast Iron body; Gunmetal spindle and sealing rings.
 - o BS-3464, flange to BS-10;1962.
 - o Test Pressure = 225 psi.
- g) Copper alloy sluice valve (size 2-1/2" and below)
 - o BS-1952; threaded ends.
 - o Test Pressure = 225 psi
- h) Cast Iron Check Valves (Size 3" and above)
 - o Cast Iron body; Gunmetal door.
 - o Test Pressure = 225 psi.
- i) Copper Alloy Check Valve (Size 2-1/2" and below).Threaded ends. Test Pressure = 225 psi.
- j) C.I. globe valves (Size 3" and above). Similar to Cast Iron Sluice Valve.
- k) Copper alloy globe valve (Size 2-/12" and below).Threaded, Test Pressure = 225 psi).
- l) Fire Hydrant
shall conform to BS; 750, with a body of Cast Iron and spindle of Manganese bronze. The direction of closing shall be by Clock wise rotation and the outlet shall have screwed joints for accommodating 2-1/2" dia hose connection.
- m) Double Air Valve
 - o Cast Iron body
 - o Max. Working head

	2	3	4	6
Din (in).				

Head (ft).	200	575	575	575
---------------	-----	-----	-----	-----

n) **Pressure Reducing Valve**

The valve shall maintain a constant downstream pressure regardless of changing flow rate and/or varying inlet pressures. It shall be spring loaded, hydraulically operated, pilot-controlled diaphragm-type globe valve. The valve shall have a single removable seat and resilient disc. The body and cover of the valve shall be of cast iron for valves of size 3" or above and shall be of cast bronze for size 2-1/2" or below. The inlet and outlet of valve shall be threaded for size 2-1/2" or below and flanged for sizes 3" or above. The working pressure for valve shall be 175 psi minimum and the valve permit a convenient adjustment over a range of no less than 30 psi. The threaded valve shall be installed with two unions at its inlet and outlet end of facilitate its removal. All pressure reducing valve assemblies will be installed with bypass line having globe valve/gate valves so that removal of P.R.Valve for servicing/repair will not disturb the service of that circuit.

o) **Strainer:**

a) The straight cast iron strainer shall be installed on the submerged end of suction pipe drawing water from ground water from reservoir. The strainer flange shall conform to the specifications of BS 10, 1962. Minimum length of strainer for the specified dia shall be as follows :

<u>Dia</u>	<u>Length</u>
3"	5-11/16
5"	7-1/2"

b) The strainers shall have cast iron or bronze bodies suitable to withstand the working pressure, removable screens of copper, brass, nickel or stainless steel, flanged bodies with tapings for size 1-1/2" and above and of such a design as to allow blowing out of accumulated dirt and easy removal and replacement of strainer screen without disconnecting the main piping.

p) **Puddle Plates:**

Puddle plates of specified dia, shall be provided where G.I. pipe crosses R.C.C. wall retaining water or soil. 3/8" thick M.S. square plate of size shown on plan. cut with a hole equal to external dia of pipe, shall be welded with the pipe with both ends of G.I. pipe provided with flanges, and the whole assembly shall be hot- dipped galvanized before being cast in R.C.C. wall.

q) **Float Valve, Level Controller, Flow Switch**

Tender to provide Specifications of items locally available.

a) **Float Valve**

The float valve shall be direct float operated valve having globe body. The valve shall close drop-tight, at pre-set maximum water level, against pressures of up to 70 psi and shall open and close in direct proportion to rise or fall of water level.

The valve shall be of all brass construction with copper float and replaceable rubber seat and shall be furnished with threaded inlet and outlet ports for sizes 1-1/2" and below. For sizes 3" and above, the valve body shall be of cast iron with copper float, replaceable rubber seat and flanged ends.

The space available for the float valve, above, maximum water level and location of valves shall be as shown in the Plans.

b) **Liquid Level Controller**

Liquid Level Controller, (float less type) comprising of control unit (for dual tank system) probe fittings complete with the electrodes and electrode holders suitable for operation on the Single Phase, 240V, 50Hz supply shall be employed wherever shown on the Plans. The controller shall have built- in surge arrester. There guaranteed electrical life of the controller shall be 5x50000o operations minimum and the minimum tolerance of the rated voltage shall be + 15%.

r) **Pipe Sleeves for Cast Iron Pipes**

The Contractor shall supply and install the pipe sleeves in partition walls, RCC walls, slabs and other structural elements slabs). The pipe sleeves shall be located accurately and they shall be properly aligned and tied with the reinforcement bars so that the alignment and level is not disturbed during concreting.

The RCC wall pipe sleeves shall be fabricated from correct size Schedule 40 M.S. pipe. M.S. 3/8" thick sheet ring of sleeve size +6" shall be welded at the centre line of the sleeve to anchor the sleeve in RCC structure. After fabrication, the sleeve shall be heavily galvanized before installation. The inner galvanized surface shall be smooth.

RCC slab pipe sleeves shall be of construction as above but fabricated from 3", 4", 5" and 8" dia Schedule 40 M.S. pipes and anchor ring shall be of 9-1/2", 10- 1/2", 11-1/2" and 14-1/2" dia respectively.

u) **Pipe Seal for Cast Iron Pipes**

All exterior openings provided for the passage of piping shall be properly sealed with snugly fitting collars of metal or other approved rat- proof material securely fastened into place.

1.3 CONSTRUCTION REQUIREMENTS

1.4 **EXCAVATION & REFILLING OF TRENCHES FOR PIPE WORK**

The trenches shall be set out to suit alignment of the pipe lines. The trenches shall be carefully trimmed at sides and bottom compacted so that pipe lines when laid shall rest on the natural bed throughout the length. Shallow joint holes being left for the joint, where necessary. Where pipe line is to be laid in plains the depth of Cover, i.e. the normal distance from ground level to other top of the pipe be kept at about 80 cm (2'- 9") and shall not be less than 75 cm (2'-6") except due to special reasons the Engineer directs in writing to the contrary. The maximum depth of trench shall be taken as shown under :

I	II	III
For pipes upto & including 38mm	For pipes 50 mm to 75mm (2" to 3')	For pipes over 75mm (3") dia
50 cm Depth (20")	50 cm Depth (22")	60 cm Depth (24")

After the pipes have been laid, jointed and tested and proved to be water tight the trench will be filled in 15 cm (6") layers compacted and watered as required. Before that 6" thick sand cushion shall be provided around the pipe.

The various materials excavated to be separated and stacked, so that in refilling they may be again related in the same order, and thus least possible damage be done to public roads, cultivated fields, etc.

1.5 **JOINTING SCREWED JOINTS**

1.6 **LAYING & JOINTING G.I. PIPES**

All screwed joints, shall be examined before jointing to ensure that the threads are perfect. In case of any flaw proper dies be used to make threads before they are jointed. The screwed ends of the pipes or specials to be jointed, shall be very slightly tapered so that as the joint is screwed up, the threads shall bind together more and more tightly to ensure water tightness. The jointing work shall be so arranged in case of every joint that the two ends of pipes or specials jointed thereby shall be equidistant from the middle of the socket and shall have a space of not more than about a quarter of an inch between them in the center of the socket. Before any joint is made all burs from the ends of the threaded joints shall be removed. For ensuring tightness against leakage Teflon thread tape shall be used in all joints. For this purpose, hemp or jute or any material other than that described above shall no account be allowed to be used. The pipes shall be screwed up tightly with pipe fitter's tongs or wrenches to ensure that each and every joint is perfectly water tight against the test head of water.

1.7 **FLANGES**

Flanged joints shall be provided at intervals of not more than 152m (500 Ft.). Each flanged joint shall be made by inserting an accurately cut disc of tough multiply rubber insertion about 3.2 mm (1/8 mm) thick of approved quality between the flanges. The bolt holes in the rubber insert as well as in the flanges shall be drilled to template. The bolts and nuts for all flanged joints shall consist of British Standard mild steel, hexagonal, round and hexagonal. The bolts shall be pulled up gradually and evenly by the use of standard spanners, so as to ensure a perfect joint.

1.8 **BENDS, TEES AND OTHER SPECIALS**

Bends, tees and reducers and other specials shall be provided and jointed at points as shown on the drawings or as directed by the Engineer. All changes in direction shall be effected by means of bends wherever practicable and the use of elbows shall be restricted only to cases where there is no room for bends. In such cases only round elbows will be allowed.

1.9 **TEST**

All pipe lines in course of or after laying and jointing but before being covered, shall be tested hydraulically, using a test pump fitted with accurate pressure gauge to be approved by the Engineer to test pressure of at least 1.5 times their normal operating pressure. All pipes, specials and fittings with their joints shall remain perfectly water tight under the full test head for a period of not less than two hours after the whole length of the pipe line has been examined and demonstrated to be water tight.

1.10 **PIPES ATTACHED TO WALLS OR CEILINGS**

- a) Provide suitable and substantial mild steel duly enamel coated hangers and supports for all horizontal and vertical line of approved types and make special vibration eliminating and flexible hanger shall be provided for all pipe work affected by moving machinery or expansion and contraction including building expansion joints.
- b) Hot and Cold horizontal piping shall be supported in accordance with the following schedule:

	Pipe Size Spacing	Minimum Hangers	Rod Size
1-	1- 1" and smaller	8 feet-0 inch	3/8"
2-	1-1/4"-2 inch	9 feet-0 inch	3/8"
3-	2-1/2-4" inch	10 feet-0 inch	1/2"
4-	6" and larger	12 feet-0 inch	1/2"

- c) Hanger shall be supported from approved concrete inserts in concrete slabs for all pipes 2" and above. Insert shall be as approved by the Engineer, and shall have space for nuts of all size. All inserts shall have a reinforcing rod of specified diameter to be installed through slot provided for this purpose, and the Contractor shall be responsible for its being in place when concrete is poured. The Contractor shall place all inserts in pour for all pipes which are to be hung, in ample time to allow the Contractor for general consideration to perform his work on schedule. If any pipe has to be hung in space where no inserts have been provided, the Contractor shall drill holes from below through concrete slabs and provide rods and hangers attached to not less than two approved type expansion shield each one capable of taking full maximum load. The rods and complete hangers shall be of adequate size to support the load which they carry.
- d) Provided approved roller supports, floor stands wall brackets, masonry, etc. for all lines running above the floors, and which can be properly supported by the floors of walls. Pipe lines near walls may also be hung by hangers, carried from approved wall bracket at a higher level than the pipe.
- e) No piping shall be hung from the piping of other trades or other piping except for small water branches in toilet where no other practical means of support can be found, in which case specific approval of the installation shall be obtained from the Engineer. Hangers shall not be fastened by means of vertical expansion bolts. Hanger shall be of heavy construction suitable for the size of pipe to be supported. All materials, except roller shall be a malleable iron or steel. Rollers shall be cast iron. Hanger shall be swivel split ring, wrought pipe clamp, or adjustable type or as approved.
- f) Special care shall be taken in the placing of hangers at the top, bottom and in offsets of hot water risers, so as to allow for expansion of the vertical piping. Vertical risers shall be securely supported from the building construction by means of pipe clamps at every floor, or as too short to connect to the building construction.
- g) For cast iron hub and spigot pipe and fittings hangers shall be provided on not more than 5 feet centres or a minimum of one hanger per each length of pipe. Where excessive number of fittings are installed between hangers, the Contractor shall provide additional hanger or reinforcing as required and to the satisfaction of Engineer. Securely anchor fittings to the building construction changes of direction to eliminate all horizontal movement. The Contractor shall furnish and install steel channels and angles for piping support. These supports will be required at those floors which are not slabbed over and/or where the building structure is not directly useable for pipe support.

1.11 PIPES SLEEVE

Every pipe line laid through any RCC walls, floors, ceilings or roofs shall be arranged to pass through proper hot dipped galvanized sleeve pipes as approved by the Engineer or ample diameter embedded therein to enable the pipe lines to pass easily and freely. The length of every such sleeve pipe shall be of the full width or thickness of the wall and in the case of roof, ceiling or floor, shall be at least 4 cm (1-1/2") longer than the thickness thereof and shall project to that extent above the upper surface thereof unless the Engineer orders to the contrary.

1.12 INSULATION FOR HOT WATER LINES

All hot water lines shall be insulated with sectional fibre glass insulated properly wrapped by 4 ounce canvas in the approved manner and as directed by the Engineer. The hot water circulation and hot water main and branches of sizes 2" and above shall be insulated with 1 inch thick insulation, while all other hot water pipes and fixtures branches shall have minimum thickness of 1/2" insulation.

All fibre glass insulation shall be of sectional type having a minimum density of 4 lbs. per Cft.

After insulation, buried or embedded hot water pipes and branches, shall be wrapped with bituminised hessian with final two coats of brush applied bitumen to make the entire insulated piping totally water proof. All pipes insulation exposed to the sun shall be protected with G.I cladding.

1.13 DISINFECTION FOR WATER SUPPLY

After the testing of the pipe work has been satisfactorily completed and when approved by the Engineer, the Contractor shall disinfect the pipe lines by dispensing chlorine solution through the entire pipe network to obtain a minimum chlorine content of 50 mg/litre for a contact period of at least 30 minutes. the procedure and equipment used to introduce, disperse and test the chlorine in the pipe shall be subject to approval by the Engineer.

1.14 MEASUREMENT

The pipe work 150 mm (upto 6" dia) shall be measured in running foot and no separate measurement will be done for tees, bends, elbows, unions and other fittings. Unit of measurement for pipe work shall be taken along the centerline and unit of measurement will be one linear Ft.

1.15 RATE AND PAYMENT

The rate shall include all cost of material i.e. pipe, fittings, jointing material, lubricant, sleeve pipes, hangers and clamps, fibre glass insulation and labour of every type and incidentals.

SECTION - 2 PLUMBING AND SANITARY WORK

2.1 DESCRIPTION

Work under this Section includes supplying and fixing all sanitary works including English type W.C., squatting, or Asiatic W.C. wash hand basins, urinals sinks, low down and high level cistern, automatic flushing tank showers, Taps, Valves and Fire Hydrant. Also any special fixtures called for on the plans and mentioned in the Bill of Quantities.

2.1.1 Material Requirements

2.1.2 Plumbing Fixtures and Fittings

- 1- European type water closet of not less than 19" (475 mm) clear opening between flushing rims in white earthenware Kohler or Roca or equivalent "P" or "S" trap 3 gallons (13.5 litres) enamelled, wall flushed type flushing tank, enamelled flush bend, PVC syphonic type fittings complete with corrosion resistant alloy ball valve of best quality manufacture in Pakistan. Standard seat and cover with PVC rings and nuts and rubber buffers, etc. complete.
- 2- European type water closet of not less than 19" (475 mm) clear opening as measured between flushing rims with raised foot rest in white earthen ware best quality Kohlar or Roca or equivalent with back or front flush, specified dia C.I. trap of the same make, 3 gallons (13.5 litres C.I. low level flush tank with syphonic type flush fitting corrosion resistant alloy or plastic ball value of Asia or equivalent 1-1/4" (31 mm) dia telescopic flush C.P. pipe of the same size fixed to wall with PVC/C.P. saddle.
- 3- Wash basin of specified size in white colour earthen ware Kohler or as per architect's specification with 1/2" (15 mm) C.P. pillar cock, 1- 1/4" (31 mm) C.P. waste chain plug, local made heavy counter sunk screws, C.P. waste pipe with bottle trap, 1/2"(15 mm) C.P. type cock heavy duty with 1/2" (15 mm) C.P. inlet connection 1/2" (15 mm) C.P. brass union nuts washers, including pedestal 2 coats of approved enamel paint to C.I. brackets.
- 4- Urinal size 17" (425 mm) in white earthen ware Kohler or Roca with pull/push valve globe valve chrome plated.
- 5- The shower roses shall be chromium finish universal type with adjustable spray of best quality local made as per approval.
- 6- The sink shall be of stainless steel best quality Kohler or Roca make as per specifications

NOTE

- 1- European type W.C., Asian type W.C., Wash Hand Basin and Urinals shall be approved make.
- 2- C.P. brass waste and union 1-1/2" 1-1/4" (38mm/31mm) dia with PVC/C.P. down pipe to be provided for sinks and wash hand basins.

2.1.4 Taps

All taps shall be of heavy duty European Made , chromium plated or brass as applicable and be of Kohler, Roca or Grohe Europe.

2.1.5 Gas Heating Equipment

The gas water heater shall be gas fired, direct, storage type with dual wall construction and be made of galvanized steel sheet. The heater shall be furnished with 1" dia drain pipe at bottom.

Electric water heaters, wherever specified, shall be direct type, fitted with electric immersion element and 3/4" dia drain plug. The body of heater shall be made of galvanized steel sheet.

The gas and electric water heater shall be locally manufactured and be able to sustain working pressures upto 50 psi without any leakage. The rated heat capacity of all the heating equipment in terms of BTU per hour or kW shall be such as to raise temperature of volume of water equal to the specified capacity of heater, by 55 degree centigrade, in one hour.

The heaters shall be furnished with temperature indicator, thermostat to control switch ON/OFF operation and pressure relief valve.

The Contractor shall submit following information about heating equipment, before installation.

- a. Manufacturer's technical Bulletin
- b. Storage capacity (gallons), rated heat input capacity (BTU per hr/kW), Thermal efficiency etc.

2.1.5.2 Thermostatic Control Water Mixer Unit

Wherever indicated on plans, thermostatic control water mixer unit shall be installed on hot and cold water pipes, near outlet of water heater to control the temperature of supply at source. The mixer unit shall be of import quality and made of stainless steel. The mixer unit shall operate satisfactorily for the following ranges of temperature.

Output	temperature	41 - 45	degree centigrade
Input	temperature		
	Hot water	55 - 60	degree centigrade
	Cold water	10 - 20	degree centigrade

The Contractor shall submit manufacturers technical bulletins, for the suggested mixer unit, for approval.

2.1.6 Hose Reel Cabinet

The hose cabinet shall be of 18 gauge heavy stock steel with joint. The face of cabinet metered, welded, ground finish and smooth with no visible seems or joints on face of cabinets. All joints shall be electrically welded. Doors to be furnished with full face wired plate glass panel, removable and secured with extruded vinyl glazing finish hinges shall be special alloy forged bronze, finished to exterior of cabinet. Knobs shall be semi recessed, cam action latch, forged bronze with chrome plate finish set in stainless steel cup. No screw or bolts heads shall be used on face of cabinet. All concealed surface of cabinet shall be prime coated after fabrication to prevent corrosion. All interior exposed surface shall be finished in baked enamel to be confirmed by the Architect through Engineer for colour scheme. the exterior shall be prime coated and left in condition for finished painting. Cabinet shall be surface mounted as indicated or approved. The cabinet includes Hose-pipe 100 feet length with brass nozzle and coupling complete in all respects. The Cabinet includes

2-1/2" dia canvas hose pipe of 100 feet length, properly joined with hydrant on supply end and with 1" dia brass nozzle on discharge end. The hole assembly including hose pipe shall be tested for a minimum test pressure of 140 p.s.i.

2.2 CONSTRUCTION REQUIREMENTS

2.2.1 Water Closets

The work shall consist of providing and fixing in position European type water closet of an approved manufacturer white/light coloured Kohler, Roca or Equivalent. The squatting type pan shall be of white vitreous China, glazed fire, fire clay, or any other approved non-absorbent material with specified diameter trap of the same material and foot rest. The surface shall have a glazed finish with minimum of fouling area and a seal depth greater than 50 mm. The outlet shall be placed well back and the pan shall be sufficiently long to meet the design requirement. The flushing water connection shall be from the rear end.

The European type water closet shall also be made of an approved manufacturer with low level flushing cistern and with double seat cover. The W.C. shall be of symphonic type with large water area and deep seal, the cleaning being effected by symphonic action. It shall have a low trap at the floor line so that the closet cannot be untrapped by the emptying water.

The low level flushing cistern shall be of 13.6 litres capacity of Ceramic as specified in the BOQ. The Cistern shall be provided with a corrosion resistant alloy or plastic ball valve with float of dia not smaller than 100mm and an additional 13mm cock and shall be provided with an over-flow pipe at least one size larger than the supply pipe, with a minimum internal diameter of 18mm and it shall be fixed on mild steel or cast iron cantilever brackets, if required and as shown on the Plans.

The flush pipe shall be 'plastic' PVC or chromium plated steel pipe. the holes for inlet, outlet and overflow in the cistern shall be made water tight by inserting rubber washes or other means of providing a water tight joint. The position of water closet shall be so arranged that it shall not face Qibla.

Every water closet shall be provided with a water supply bib tap for filling the small water cans in the site down position. A chromium plated toilet paper holder close to each water closet shall also be installed.

2.2.2 Sink

Sink shall be of enamelled iron or 18 gauge stainless steel of size as specified in the BOQ with self-contained drain boards of approved manufacturers. The sink shall be fitted with rubber plug and washers, 38mm dia chromium plated bottle or S trap with waste pie with all necessary accessories for making the sink a complete units. The internal angles shall be of a design to facilitate cleaning with a fall towards outlet to drain the contents completely.

2.2.3 Service Sink: if required shall be made of stainless steel of 16 gauge as approved by Engineer. The sink shall be used for drawing water for scrubbing and cleaning and to dispose off the contents of scrub buckets and vessels containing slops. The edge of the sink shall be placed about 600 mm above the floor to minimize lifting and to leave room for the trap beneath.

The water supply and drainage equipment for such sinks shall be similar to that for kitchen sinks, except that no hot water supply or mixer will be installed.

2.2.4 Water Pump

Pumps for Domestic Water, Fire Fighting, Drainage and Sewage Lift Station

The centrifugal pump-motor sets shall be heavy duty industrial type suitable for continuous and quiet operation.

The centrifugal pumps shall be single stage, small size of vertically split casting and large sizes of horizontally split casing as specified in the Schedule of Equipment.

The pumps to be volute type, cast iron body, fully bronze fitted, bronze impeller of radial type with double curvature vanes, stainless steel shaft or shaft sleeve, properly lubricated bearings, readily accessible stuffing box with packing and seal cage, flanged suction for the pump and the motor and the pump shafts covered with approved guard, pump casing to be complete to be completed with drain and vent plugs and designed, tested and proven tight for a test pressure at-least equal to 1.5 times the maximum working pressure.

The pumps to have the gate valves and strainers on the suction side, globe valves on the discharge side and pressure gauges on suction and discharge sides. If pumps are operating in parallel then a check valve to be installed on the discharge side of each pump.

The pumps shall be direct driven by a constant speed motor and provided with a suitable starter. The pump motor HP has been given for each system for guidance but it is intended that motor of higher HP shall be provided if required to ensure that it is not overloaded under any possible operating conditions of the pump.

Each pump shall be guaranteed for circulating the specified water quantity against specified net discharge head under the specified conditions of operation when operating continuously without overheating the motor, bearings, etc. However, the CONTRACTOR will check and confirm the actual discharge head required before placing orders for the pumps. The pump shall be selected for quiet operation so that pump noise is not audible outside the plant room. The pump sound shall not be transmitted to the Building Structure.

The pumps installed for one system should be suitable for parallel operation in all respects. The pump impeller and motor should be so selected that these are not overloaded when only one pump is operating and increased water flow is to be handled due to reduced system head.

The CONTRACTOR shall supply anti-vibration foundation material (Both pads for isolator of main foundation and spring mountings for inertia mass) for isolating the pump foundations from the Building structure.

The number, size and conditions of operation for pumps required for different systems are specified in the Scheduled of Equipment and the pumps location shown in the drawings.

Certified performance data and curves shall be submitted by the CONTRACTOR for approval to confirming the purchase order on the manufacturer/supplier.

The Tenderer to give following information for the pump:

- a) Pump capacity in Usgpm against net discharge head, RPM, HP of motor, and pump maximum HP requirement.
- b) Construction and other technical details.
- c) Overall dimensions and operating weight.
- d) Manufacturer's Performance Guarantee Certificate and performance data and curves and technical bulletin.

The sewage ejector submersible centrifugal pump motor sets shall be vertical heavy duty Industrial type with non-clogging impeller suitable for continuous operation.

The pump capacity rating shall be as specified in the Schedule of Equipment.

The pump shall be vertical single entry single stage non self-priming. The pump casting shall be radially split open towards the discharge end sealed off by a cover, suction end with a renewable wear plate and nozzle, impeller suitable for mixture of contaminated fluids, solid particles and sludges. The shaft length shall suit the installation depth shown in the drawings and shaft pieces joined together by threaded shaft coupling. The weight of the rotor and axial thrust will be absorbed by deep groove ball bearing in the vertical hollow shaft motor. A grease pump mounted on the pump mounting plate shall continuously feed grease individually to every bearing during pump operation. The pump shall be fitted with soft packed stuffing box fed with sealing grease. the pump base plate shall be sized large enough to enable the pump to be pulled out/lowered into the pit without the necessity of enlarged pit roof opening. The pump discharge line will be terminated above the base plate. The wear plate shall be of cast iron, shaft protecting sleeve of stainless steel, shaft of carbon steel, base plate of steel, motor stool of steel/cast iron and bearing of lead bronze.

The pump motor sets to be of local manufacture, KSB type KVP or approved equal.

Level Controllers

Each group of the above pumps shall have a control system as detailed below :-

A three position level controller shall automatically control the pump operation. The level controller shall start the pump at high level and stop the same at low level. A highest level, the level controller shall energise an audio-video alarm.

2.2.5 Unions

Provide accessible unions in supply and return connections at all equipment fixtures, fixtures, specialists automatic valves, screwed end valves and at all other points in the system where required, in order to facilitate removal of specialities or equipment for repairs.

2.2.6 Expansion Joints for C.I. Soil or Waste Pipe

Expansion joint in C.I. soil or waste pipe shall be provided as pre plans, where the pipe crosses building expansion joint. These will be of non- pressure type, similar to imported Jossam Series.

2.3 MEASUREMENT

Measurement shall be made for the number of fixtures and toilet accessories acceptably provided and fixed in position.

2.4 RATE AND PAYMENT

Payment shall be made for the number measured as provided above at the contract unit rate for the respective items in the Bill of Quantities and shall constitute full compensation for all labour, material, use of equipment and tools required for work related to the item including providing and fixing all other work to complete. The item in all respects as specified or as directed by the Engineer.

SECTION - 3 SEWERAGE/DRAINAGE WORK

3.1 DESCRIPTION

3.1.1 Sewerage Pipes

All sewerage/drainage pipe work inside the houses and buildings and upto the connection to the trunk sewer shall be covered under this section. The pipes shall be RCC or C.I. as specified including soil, waste, vent and anti-syphonic pipes.

3.2 MATERIAL REQUIREMENTS

All RCC/C.I./UPVC pipes shall conform to the specifications referred to in Section "

Materials " and as specified in this section. UPVC water piping shall conform to ISO 3633 & PS 3214 or other equivalent specifications with solvent cement or rubber ring joints as specified.

For Cast Iron Pipes, the joints shall be lead caulked. The packing material shall be pure jute, hemp or hemp yarn. All exposed C.I. pipes and fittings shall be painted with 2 coats of black enamel over one prime coat.

For RCC pipes the cement mortar to be used on joints shall be of 1:1 ratio or as per Plans alongwith rubber ring. Material specifications for sewerage and drainage shall be as follows:-

- a) Cast Iron spun Pipe, socket and spigot (6' length)
 - o Minimum Weights

Dia (in)	2	3	4	6
Weight (Lb.)	24.9	37	48	72.9
 - o Test Pressure against leakage = 20 psi.
- b) Cast Iron Fittings
 - o Minimum Weights (Lb.)

TABLE - 1 (BENDS)

Fittings (Inches)	2	3	4	5
87-1/2 degree and 45 degree Bend with out access	6.8	11	15	24.9
87-1/2 degree and 45 degree bend with Access	7	11.9	18	29.9

TABLE (WYES & REDUCERS)

Fittings (inches)	2x2	2x3	3x3	2x4	3x4	4x4
87-1/2 degree and 45 degree without access	9	15	16	17	20	24
87-1/2 degree and 45 degree Wye with access	11	16	18	20	24	26
Eccentric Reducer with smaller side socketted -	-	7.9	-	11	11	-

- c) R.C.C Pipe
 - o BSS 556 : Class-M < 9"
 - o 6" dia pipe with collar
 - o 9" pipe, spigot and socket
 - o ASTM C76-72-a > 12"

3.2.1 **Cast Iron Floor Trap, Manhole Frames and Cover, Grating**

These shall be cast from a mixture of cast iron scrap and suitable grade of pig-iron, and resultant metal shall be of strong grey structure, free from chips, air bubbles and sand holes and shall be smooth and even both inside and outside.

3.2.2 **Grease Trap**

Grease Trap shall be made of cast iron, for specified flow capacity and inlet/outlet dia and provided where shown on plans. Grease trap shall be embedded in raised floor and inlet shall be submerged.

3.2.3 **Glazed Earthen Ware**

Shall be of best and approved quality and the water seal shall not be less than 63.5 mm (2-1/2") deep.

3.3 **CONSTRUCTION REQUIREMENTS**

3.3.1 **Laying of RCC Pipe**

Pipes and accessories shall be carefully examined before being laid and defective damaged pipes shall not be used. The pipes shall be brushed clean inside and outside to remove any soil or foreign matter that may have accumulated, including inside of the sockets and outside of spigots, before being lowered into the trench, and shall be kept clean during laying operation by plugging or other approved method.

The bottom of the trench shall be shaped to give substantially uniform circumferential support to the lower fourth of each pipe. Pipe laying shall proceed upgrade with the spigot ends of bell and spigot pipe pointing in the direction of flow. Each pipe shall be laid true to line and grade and in such manner as to form close concentric joint with the adjoining pipe. If the width of the trench at the pipe is exceeded than necessary, due to any reason other than under direction from Engineer, the Contractor shall install at no additional cost to the Owner, such concrete cradling pipe encasement or other bedding as may be required to satisfactorily support the added load of the backfill.

Trenches shall be kept free from water until the pipe jointing material has set, and pie shall not be laid when the condition of the trench or the weather condition is unsuitable for such work. At times when work is not in progress, open ends of pipe and fittings shall be securely and satisfactorily closed so that no trench water, earth, or other substance will enter the pipe and fittings.

As the work progresses, the interior of the sewer shall be cleaned of all dirt and superfluous materials of every description. Where cleaning after laying is difficult because of small pipe size, a suitable swab or drag shall be kept in the pipe and pulled forward past each joint immediately after the jointing has been completed. Where sewers cross above water line the sewer pipe for a distance of 3 meter (10 feet) each side of the crossing shall be of cast iron steel or other acceptable pressure pipe and with no joint closer than 3 feet (900 mm) to the crossing, or shall be fully encased in concrete of min. 15 cm. (6 ") thickness.

Any section of the pipe found to be defective before and after laying, shall be replaced with sound pipe without additional expense to the Owner. The jointing or pipes with collars shall be done first with spun yarn rope (dipped in hot maxphalt composition) fitted in between the ends of pipes and pressed together. The dia of rope shall not exceed 19mm (3/1") or as directed by Engineer.

The collar shall then be brought in the middle of the joint. Wooden wedges shall be placed at two or three places around the pipe so that the collar may have uniform gap all round the pipe for pressing pipes together. At a time five or six pipes shall be jointed together. After putting bitumen soaked hemp rope, suitable jacks and wedges or any other approved method shall be used. The inside of the collar and outside portion of the pipe shall be cleaned with brush and cement mortar of 1:1 proportion shall then be inserted from both ends of the collar. The mortar containing as little quantity of water as possible shall be carefully inserted by hand into the joints and tightly pressed with caulking tool. The mortar shall be finished off on the outside at an angle of 45 degree. The wooden wedges shall be carefully removed and mortar filled in the cavity before finishing. The joints shall be protected from weather and maintained wet for at least ten days and shall not be covered with backfill until the joints have been tested and approval given by the Engineers.

For jointing of pipes with spigot and socket joints, the first pipe shall be bedded with the socket end upstream. The interior surface of the socket shall be carefully cleaned with a wet brush and its lower portion filled with mortar to such a depth as to bring together the inner surfaces of the abutting pipes flush and even. All further joints shall be made in this manner. The remainder of the socket joint shall be filled in with mortar and well pressed with the help of caulking tool. The mortar shall be finished smooth on the outside at an angle of 85 degree. The joints shall be protected and cured as for collar joints.

3.4 **SOIL, WASTE, VENT AND ANTI-SYPHONIC PIPES**

Examination and preparation of pipes shall be as for RCC pipes. The pipes shall run exposed or embedded in walls and floors as specified or shown on drawings. Where embedding in walls or floors is required, the necessary instruction and route of pipe work shall be approved by the Engineer. Pipes running exposed on walls and ceiling shall be properly clamped with Hangers, supports and clamps. For passage of pipes through masonry wall and RCC beams, slab and walls, pipe sleeves shall be embedded and properly caulked and water proofed.

Horizontal soil and waste pipes unless otherwise specified shall be given a grade of 6.4 mm (1/4") and 3.2 mm (1/3" 1/ft. respectively. All main vertical soil stacks shall extend full size to above the roof line, except where otherwise indicated. The part of the soil stacks carried up as vent pipe shall not have any bend or angle except when unavoidable, in which case, the angle shall be as obtuse as possible. The vent stack shall joint the soil stack at a point not less than 3 feet (900 mm) above the highest connection to the soil stack. Horizontal waste lines receiving the discharge from two or more fixtures on the first floor shall be provided with end vents, unless separate venting of fixtures is called for.

Changes in pipe size on soil, waste and drain lines shall be made with reducing fittings or recessed reducers. All changes in direction shall be made by the appropriate use of 45 degree Wyes, long or short sweep 3 mm to 1.5 mm bends etc. or equivalent fittings as approved. Single and double sanitary tees and quarter bends may be used in drainage lines only where the direction of flow is from horizontal to vertical. Short sweep not less than 75 mm (3") in diameter may be used where the change in direction of flow is either in plan or vertical to horizontal and may be used for making necessary offsets between the ceiling and the next floor above. The use of short sweep bends or fittings, where deemed necessary because of installation conditions, shall be subject to the approval of the Engineer.

Contractor shall provide offsets in the piping where required or directed by the Engineer to avoid interference with other work, or to increase the headroom under piping, or to improve the appearance of the pipe work. Piping shall be installed in such a manner that will permit freedom of movement during expansion and contraction without causing the pipes to be warped and adequately insulated against noise transmission through pipe work in habitable rooms.

All piping shall be installed in such a manner as to prevent delay or interference with the work of others working in the same area. All openings in pipes shall be kept closed during construction work with plugs.

Slip joints shall be permitted only in trap seals or on the inlet side of the traps. Tucker or hub drainage fittings shall be used for mating union connections wherever practicable. The use of long screws and bushing is prohibited.

Clean-out shall be of the same size as the pipe except that clean-out plugs larger than 100 mm (4") will not be required. Clean-outs installed in connection with cast iron spigot and socket pipe shall consist of a long sweep 1/4" bend or one or two 1/8" bends extended to any easily accessible place, or where indicated on the drawings. An extra heavy castbrass ferrule with outersunk trap screw cover shall be caulked into the hub of the fitting and shall be flush with the floor. Where clean-outs in connection with threaded pipe are indicated and are acceptable, they shall be cast iron drainage T-pattern 90 degree branch fittings with extra-heavy brass screws plugs of the same size as the pipe upto and including 100 mm (4"). Test tees with cast iron clean-out plugs shall be installed at the footing of all soil, waste, and drain stacks and on each building drain outside the building. In addition, clean-outs shall be provided at all changes of direction in excess of 45 degree, and at distance not exceeding 15 meter (50 feet) in horizontal drain line 100mm (4") and smaller size, and not exceeding 30.480 mm (100 feet) in drain lines larger than 100 mm (4"). Underground clean-outs shall be extended to an accessible location, to the surface of the floor above, or to grade, subject to approval of the Engineer. Panels and plates for access to clean-outs shall be provided.

Each fixture and piece of equipment, including floor drain, requiring connections to the drainage system shall be equipped with a trap. Traps are to be supplied with the fixtures. Each trap shall be placed as near to the fixtures as possible, and no fixture shall be double-trapped. Except as otherwise indicated traps installed on bell and spigot pipe shall be cast iron. Traps installed on threaded pipe shall be recess drainage pattern.

3.5 **FLOOR TRAPS**

Floor traps with gratings shall be made of high grade, strong, tough, and even grained metals, Castings shall be free from blow holes porosity, hard spots, excessive shrinkage cracks, or other defects, shall be smooth and well cleaned both inside and outside. Castings shall not be repaired, plugged, brazed, or burned. The wall thickness of iron casting shall be not less than 6.4 mm (1/4").

Joints for Cast Iron soil, waste and vent pipes shall be made with lead, jute, hemp or hempen spun yarn. The packing material shall be well placed into the annular space so as to prevent the entrance of lead into the pipe. Run lead joints shall be applied to perfectly dry pipes. Under wet condition lead fibre joints shall be made both with quantities and depth of jointing materials and by method as per B.S. Code C.P. 301 (1950). The remainder of the space shall be filled with molten lead that is hot enough to show a rapid change in colour when stirred. The lead shall be caulked to form a tight joint without over straining the bell.

3.6 TESTING OF PIPELINES

No work shall be covered over or surrounded with concrete until it has been inspected, tested and approved by the Engineer.

3.7 INSPECTION AND TESTING OF DISCHARGE PIPES

Work should be inspected and tested during installation, care being taken that all work which is to be concealed is tested before it is finally enclosed. Final tests should be applied on completion of the installation both for soundness and performance. Normally, the air test is used for soundness, but if the water test is applied, it should be used only up to the level of the lowest sanitary appliance connected to the system, and then only in new system.

When testing old systems, it may be necessary to limit the pressure applied because of shallow trap seals; the water test should not be used. Any defects revealed by the test should be made good and the test repeated until a satisfactory result is obtained.

Reference should be made to Local Authority and other enforcing authority requirements, particularly where pipe work passes through areas where blockages and leaks cannot be detected. In general, sufficient access should be provided to enable complete systems to be tested.

Access points should be carefully sited to allow the entry of cleaning and testing equipment and consideration also be given to adjacent services. Traps and joints that are easily disconnected can be an advantage so additional access is required only under exceptional circumstances.

The discharge from urinals can give rise to heavy deposits, especially in hard water areas. Regular maintenance is therefore required and access should be provided so that all parts of the stack, branch, discharge pipe and trap can be readily cleaned. Where the vertical discharge pipe has a long connection to a manhole, access should be provided at ground floor near the foot of the stack.

In multi-storey domestic buildings, access should be provided at 3 storey intervals or less. In public and commercial buildings and more complex, drainage systems, access should be provided at each floor level.

The discharge from appliance produces pressure fluctuations and the system must be designed to retain adequate water seal in all traps under excessive working conditions. Pressure effects that occur may be due to self siphonage or positive pressure. It may be necessary to use a ventilating pipe to limit the pressure fluctuations in the system within the acceptable limits.

The effect of the flow of water from an appliance into a branch discharge pipe must be considered taking account of:

- a) The design of the appliance (funnel shaped appliances increase the possibility of self siphonage)
- b) The length, slope and diameter of the branch discharge pipe.

Seal losses produced by effluent flow down the discharge stack depend on:

- a) The flow load which in turn depends on the number of appliances connected and frequency of use.
- b) The diameter of the discharge stack.

Air Test

An air test should apply a pressure equal to 3.8 mbar (38 mm) (50 mbar (50 mm) Scotland) water gauge and should remain constant for a period of not less than three minutes (five minutes Scotland). The water seals of all sanitary appliances which are installed should be fully charged and a test plug inserted into open ends of the pipework to be tested, each plug being sealed with a small quantity of water. One testing plug should be fitted with a tee-piece, with a cock on each branch, one branch being connected by a flexible tube to a manometer.

To apply the test, air or smoke is introduced into the system through the other branch of the tee-piece until the desired pressure is shown on the manometer scale. Alternatively, the pressure may be applied by passing a flexible tube from a tee-piece attached to a manometer through the water seal of the trap of a sanitary appliance, the test then being carried out as previously described. Defects revealed by an air test may be located by the following:

- a) A smoke producing machine may be used which will introduce smoke under pressure into the defective pipe work. Leakage can be observed as the smoke escapes.
- b) Soap solution can be applied to the pipes and joints, under test, leakage can be detected by the formation of bubbles.

Performance of Testing Systems

In addition to a test for air or water-tightness, every discharge pipe installation should be tested for stability of the trap seals on the system. When subjected to the appropriate discharge tests, every trap must retain not less than 25 mm of water seal. Each test should be repeated three times, traps being recharged before each test and the maximum loss of seal in any one test should be taken as the significant result.

The number of appliances to be discharged simultaneously for the test depends upon the number of appliances installed and the use and occupancy of the building. Suitable figures are given in Table C9 for dwellings. For other types

of buildings, e.g. hotels and hospitals, the service conditions lie somewhere between these two. The number of appliances to be discharged simultaneously to simulate these conditions should be estimated from the figures given in Table C9 the expected service conditions.

Dwellings

To test for the effect of self siphonage, waste appliances should be filled to over flowing level and discharged in the normal way. The seal remaining in the trap should be measured when the discharge is finished.

To test for the effects of probable maximum simultaneous discharges of sanitary appliances, the number of appliances to be discharged together is given in Table C9. For the purpose of this test, baths are ignored as their use is spread over a period and they do not normally add materially to the peak flow.

Where a stack services baths only, the number to be discharged simultaneously in a test should be the same as for sinks. The worst conditions occur when appliances on the upper floors are discharged. A reasonable test therefore is to discharge up to one WC, one basin and one sink from the top floor of the building with any other appliances to be discharged on the floor immediately below.

Table: C9 Number of appliances to be discharged simultaneously for testing stability of seals; Dwellings

Number of appliances of each kind on the stack	Number of appliances discharged simultaneously		
	WC 9 litres	Wash Basin	Kitchen sink
1 – 9	1	1	1
10-24	1	1	2
25-35	1	2	3
36-50	2	2	3
51-65	2	2	4

RCC pipes below 300 mm dia shall conform to B.S. 5911 Class-C and dia 300 mm or above to ASTM C76-88.

3.8 MEASUREMENT

All pipe work shall be measured in running foot of finished length. No wastage or length consumed in joints shall be measured for payment. Sockets, spigot and RCC collars shall not be measured separately.

For cast iron pipe line the length consumed in valves, fittings and specials shall be measured alongwith pipe line.

Cast Iron specials and fittings such as Tees, Tapers, Bends, Shoes, Crosses, Offsets, flanged sockets and spigot, plugs and caps etc. shall be measured alongwith the pipeline.

3.9 RATE AND PAYMENT

The rate for all items under this section shall cover the cost of all materials, labour, tools, equipment and appliance and performing all operations for laying, fixing and jointing and all work as specified in accordance with drawings, bill of Quantities and as directed by the Engineer. Rate for pipe work shall also include making and repairing cut holes and chases in walls, floors and slabs etc. painting pipes, supports and accessories cleaning and clearing pipe lines and testing till approved by the Engineer.

SECTION - 4 CONSTRUCTIONS OF MANHOLES

4.1 DESCRIPTION

The work consists of constructing manholes for sewerage of positions shown on the plans or where otherwise directed by the Engineer and in accordance with the detailed drawings supplied from time to time, complete in all respects.

4.2 MATERIAL REQUIREMENTS

Brick masonry, portland cement concrete, and other materials shall materials shall meet the specified requirement of the relevant sections of the specifications for RCC given Section- "Portland Cement Concrete" Manhole steps shall be of mild steel as shown on the drawings.

4.3 CONSTRUCTION REQUIREMENTS

Manholes shall be constructed with brick masonry of specified wall thickness laid in 1:4 sand cement mortar and R.C.C. concrete slab. The cover slab shall be Class-C reinforced cement concrete, fitted with cast iron frame which shall have weight 1/2 CWT 18" (450 mm) diameter cast iron cover as shown in the plan. The inside of the walls shall be plastered with 1:4 sand cement mortar. At the bottom of manholes for sewers a proper channel as per drawings, shall be constructed in the whole length of the manhole along the centreline of the sewers, to lead the sewage from one sewer to the other. Mild Steel bar steps shall be installed inside the manhole, during the construction of the manhole walls. Cutting holes into the wall for the steps after construction will not be permitted. Top rung shall be 18" (450 mm) below the manhole cover and the lowest not more than 12" (300 mm) above the benching (Floor). Manholes shall have cement concrete Class-C benching as per drawings/specs. Manholes shall be connected with the nearby sewerage manholes

through a reinforced cement concrete pipe as per details provided. Manholes along the central and primary drains shall also act as over-flow structures. The existing over-flow pipes shall be securely connected with these manholes.

4.4 **MEASUREMENT**

Measurement shall be made for the actual number of manholes as shown in BOQs of the appropriate type constructed at site as per drawings and specifications laid down in this section and to the approval of the Engineer.

4.5 **RATE AND PAYMENT**

The unit rate quoted in the priced Bill of Quantities for the construction of manholes shall be considered full compensation to cover the cost of all materials including framework and concrete, brick masonry, excavation, backfilling, steps frame and cover, and connecting pipe with the manhole, and all labour including curing, plastering, trenching, etc. and all incidentals to completely construct them at site, as per drawings and specifications laid down in this section.

SECTION - 5 STORM WATER DRAINAGE

5.1 **DESCRIPTION**

The work under this section consists of all drainage work and related items necessary to complete the work indicated on the drawings and described in the specifications. The work includes but is not limited to the following :-

- 1- All storm water drainage piping shall be C.I. or PVC within and RCC outside buildings as shown on the plans with connections to catch pits and open drains plus all related items to complete the work.
- 2- Provide all catch pits wherever shown on the drawings with C.I. Grating and hinged grating (if required).
- 3- Provide C.I. grating at the roof inlet of all vertical rain water drop pipes, as shown on the plans.
- 4- Gravel bedding shall be provided wherever called for on the drawings or directed by the Engineer.
- 5- Testing cleaning, adjusting and placing in operation all piping installed.
- 6- Pipe culverts of sizes indicated on the drawings.

5.2 **MATERIALS**

Materials for C.I. and RCC pipe shall conform to the respective specifications specified under Section 3.2. The PVC pipe shall conform to the requirements of BSS 3505, Class- B, for which the working pressure shall be 87 psi minimum. The PVC pipes used shall be with integral parallel socket and shall be joined by solvent welding method.

5.3 **CONSTRUCTION REQUIREMENTS**

Construction Requirements of pipe work shall meet the relevant specifications appearing else-where in the documents.

5.3.1 **Protection of Works**

The installation shall be adequately protected against damage and deterioration particular care must be taken during the course of construction of seal all open ends of pipe work with a temporary cover. Wood shavings or paper will not be accepted for this purpose.

5.3.2 **Concreting of Pipes**

Where pipes are laid below a building, roads or near the surface etc. they shall be in cased in or protected with concrete as shown on the drawings. No pipe shall be concreted until the pipe has been tested to the satisfaction of the Engineer.

5.3.3 **Catch Pits**

Catch Pits shall be constructed of brick masonry with Plain Cement Concrete Class-D base of 4" thick. Catch pit shall be of the dimensions indicated on the drawings. Cast iron frame and grating shall be provided as indicated on the drawing directed by the Engineer.

5.3.4 **Drains**

Drains shall be provided in accordance with drawings. Brick drains shall be constructed of block masonry with a Plain Cement Concrete Class-E base. Internal walls of the drain shall be plastered in a (1:4) cement sand mortar of thickness, shown on the plans. Drains in concrete shall be constructed of Class-D concrete and shall be provided at positions and sizes shown on the drawings.

The drains shall be laid in straight lines and to slopes indicated on the drawings. They shall be kept free from mud debris, superfluous cement or other obstructions.

5.4 **MEASUREMENT**

All pipe work shall be measured in Running M/Ft. of finished length. No wastage or length consumed in joints shall be measured for payment. Sockets, spigot and RCC collars shall not be measured separately. Holder bats/sleeve pipes required for pipes attached to walls and ceilings going through walls shall not be measured separately. Measurement for drains shall be in Running M/Ft. Catch pits shall be measured for the number of catch pits acceptably provided.

5.5 **RATE AND PAYMENT**

The rate for all items under this section shall cover the cost of all materials, labour, tools, equipment and appliance and performing all operations for laying, fixing and jointing and all work as specified in accordance with drawings, bill of quantities and as directed by the Engineer. Rate for pipe work shall also include making and repairing cut holes and chases in walls, floors and slabs etc. painting pipes, supports and accessories cleaning and clearing pipe lines and testing till approval by the Engineer. Rate for catchpits, drains and piping shall include excavation backfilling masonry/concrete work, frame and hinges wherever called for, complete as per plans or directed by the Engineer.

SECTION – 6 EXCAVATION FOR WATER SUPPLY LINES AND APPURTENANCES

6.1 **DESCRIPTION**

The work covered by this section of the specifications consists of furnishing all plant, labour, equipment, appliances, and materials and performing all operations in connection with excavation, trenching and back filling for water lines and appurtenances in strict accordance with this section of the specifications and the applicable drawings, and subject to the terms and conditions of the contract.

6.2 **CLEARING AND GRUBBING**

The sites of all excavations shall be cleared of all shrubs, plants, bushes, large roots, rubbish and other surface materials. All such materials shall be removed and disposed off in a manner satisfactory to the Engineer. All trees and shrubbery that are designated by the Engineer to remain shall be adequately protected and preserved in an approved manner.

6.3 **EXCAVATION**

6.3.1 **General**

All excavation of whatever substance encountered shall be performed to the depths indicated or as otherwise specified. During excavation, material suitable for backfilling shall be stockpiled in an orderly manner at a sufficient distance from the banks of the excavation to avoid overloading and to prevent sides from caving. All excavated material unsuitable or not required for backfill shall be removed and wasted at a location approved by the Engineer. Excavation in the streets shall be done in such a manner that street passage is not blocked by excavated material. Grading shall be done as may be necessary to prevent surface water from flowing into trenches or other excavations, and any water accumulated therein shall be removed by pumping or by other approved methods. Unless otherwise indicated or approved by the Engineer, excavation shall be open cut.

6.3.2 **Trench Excavation**

Unless otherwise directed or permitted by the Engineer not more than 500 ft. of any trench in advance of the end of the pipeline already laid shall be opened at any time, unless otherwise directed or permitted by the Engineer not more than 1000 ft. of any one trench shall be worked on at a time from removal of pavement bottom, not exceeding 6 feet in depth shall be a maximum of 20 inches plus the external diameter of the pipe barrel and the width of the trench exceeding 6 feet in depth shall be maximum 30" plus external diameter of the pipe barrel). The banks of the pipe trench shall be as nearly vertical as practicable. Bell holes and depressions for joints shall be dug after the trench bottom has been prepared. The pipe, except for joints, shall rest on the prepared bottom for its full length. Bell holes and depressions shall be only of such length, depth, and width as required for properly making the particular type of joints. Stones shall be removed to avoid point bearing. Whenever wet or otherwise unstable material that is incapable of properly supporting the pipe as determined by the Engineer is encountered in the bottom of the trench, such material shall be removed to the depth required and the trench backfilled to the proper grade with coarse sand, or other suitable approved granular material. Such replacement of unsuitable material shall be paid for at the contract unit price for that item of work. Trenches shall be of a depth to provide a maximum cover, over the top of the pipe, of 30" from the existing ground surface or finished grade whichever is closer except that trenches for pipe laid in lanes and alleys of narrow travelled way (average width of 8 feet) or less between structures) shall be of a depth to provide a minimum cover, over the top of the pipe, of 18" from the existing ground surface or finished grade whichever is closer.

6.3.3 **Excavation for Appurtenances**

Excavation for appurtenances shall be sufficient to leave at least 12" but not more than 24" between the outer surface and the embankment or timber that may be used to hold and protect the banks. any over-depth excavation below such appurtenances that has not been directed by the Engineer will be considered unauthorized and shall be refilled with compacted sand, gravel or concrete, as directed by the Engineer at no additional cost to the Owner.

6.3.4 **Maintenance of Excavation**

All excavation shall be properly maintained while they are open and exposed. Sufficient suitable barricades, warning lights, flood lights, signs, and similar items shall be provided by the Contractor. The Contractor shall be responsible for any damage due to this negligence.

6.3.5 **Removal of Water**

The Contractor shall build all drains and do ditching, pumping, well pointing, bailing, and all other work necessary to keep the excavation clear of ground water, sewage and storm water during the progress of the work and until the finished work is safe from injury. All water pumped or drained from the work shall be disposed of in a manner satisfactory to the Engineer and necessary precautions against flooding shall be taken.

6.3.6 **Sheeting and Bracing**

If ordinary open-cut excavation is not possible or advisable, sheeting and bracing shall be finished to the work and to provide working conditions which are safe. The Contractor shall furnish and place all sheeting, shoring, wall braces, timbers and similar items, necessary for the safety of the work, the general public and adjacent property. Sheeting shoring and bracing shall be removed as the working progresses and in such a manner as to prevent damage to finished work and adjacent structures and property. As soon as withdrawn, all voids left by the sheeting and bracing shall be carefully filled with sand and compacted. The Contractor shall be fully responsible for the safety of work in progress, for the finished work, the workmen, the public and adjacent property.

6.3.7 **Protection of Facilities**

Existing subsurface facilities likely to be encountered during the execution of work require special precaution for the protection, such as sewers, drain pipes, water main, conduits and electric cables and the foundations of adjacent structures. The Contractor shall be responsible for the damage of any such facility and shall repair the same at his expense whether or not this facility has been shown on the drawings

6.3.8 **Surplus Materials**

All surplus materials shall be disposed off at locations approved by the Engineer disposal of surplus material shall not interfere with other works and shall not damage or spoil other material. When it is necessary to haul earth or the material over street or pavement, the Contractor shall prevent such material from filling on the street or pavement.

6.3.9 **Cutting Pavement**

In cutting or breaking street surfacing, the contractor shall not use equipment which will damage the adjacent pavement. Existing paved surfaces shall be cut back beyond the edges of the trenches to form neat square cuts. The road ballast, brick pavement, and other materials shall be placed on one side and shall be preserved for reinstalment when the trench is filled. Wherever necessary or required for the convenience of the public or individual residents, at street crossings and at private driveways, the Contractor shall provide suitable temporary bridges over unfilled excavations. All such bridges shall be maintained in service until backfilling has been completed. The Contractor shall keep the road crossings manned 24 hours per day. During night time, enough red lights shall be provided to warn traffic. If detour is necessary, the Contractor shall make proper detour for the traffic and shall install signs 3 feet by 4 feet in size indicated the detour.

6.4 **BACKFILLING**

The trenches shall not be completely backfilled until all required pressure tests are performed and until the water lines as installed conform to the requirements of specifications. Where in the opinion of the Engineer, damage is likely to result from withdrawing sheeting, shoring, the same shall be left in place and cut off at a level 12" below ground surface. Trenches shall be backfilled to the ground surface with selected excavated material or other material that is suitable for proper compaction. Trenches improperly backfilled shall be reopened to the depth required for proper compaction, then refilled and compacted to the specified density. The surface shall be restored to its original or better condition. Pavement and base course disturbed by trenching operations shall be required.

6.4.1 **Lower Portion of Trench**

Backfill material shall be deposited in 6" maximum thickness layers and compacted with suitable and hand tampers to ninety five percent of maximum density until there is a cover of not less than 12" over the water lines. The backfill material in this portion of trench shall consist of sandy clay or other approved materials free from stones and lumps.

6.4.2 **Remaining of Trench**

The remainder of the trench shall be backfilled with material that is free from stones larger than 6" in any dimension. Backfill material shall be compacted to 90 percent of maximum density for cohesive soils and 95 percent of maximum density for others.

6.5 **BORROW**

Where suitable material for backfill is not available in sufficient quantity from required excavations, suitable material shall be obtained from approved sources at the contractor's responsibility. The necessary clearing and grubbing or borrow areas, disposal and burning of debris therefrom, the developing of sources including any access roads for hauling and the necessary right-of-way, and the satisfactory drainage of the borrow shall be considered as incidental items to be borrow excavation.

6.6 **GRADING**

After completion of all backfilling operations, the Contractor shall grade the work areas to the lines, grades and elevation shown on the drawings. Finished grading shall not be done until the installation of all water lines has been completed and tested. The top surface after completion shall be "in level" to the adjacent existing surface. Prior to final acceptance, all damage due to settlement shall be repaired by and at the expense of the Contractor.

6.7 **TESTING DENSITY OF SOIL IN PLACE**

The Engineer may make tests using the calibrated sand cone method/core cutter method to determine the density of soil in place. If soil in place fails to meet the specified degree of compaction the areas represented by the failing tests shall be removed, replaced and compacted to the specified density in the manner directed by the Engineer and at no additional cost to the Owner.

6.8 **MEASUREMENT**

The measurement shall be made for the actual quantity of the work done in cubic feet. The maximum width of the trenches allowed for payment for various pipe sizes will be asunder:-

- a) Upto 2" diameter pipe, the trench width will be 15"
- b) Upto 3" diameter pipe, the trench width will be 18"
- c) Upto 4" diameter pipe, the trench width will be 18"
- d) Upto 6" diameter pipe, the trench width will be 21"
- e) Upto 8" diameter pipe, the trench width will be 24"
- f) Upto 10" diameter pipe, the trench width will be 26"
- g) Upto 12" diameter pipe, the trench width will be 28"
- h) Upto 16" diameter pipe, the trench width will be 32"

6.9 **RATE**

The unit rate tendered in the priced Bill of Quantities for excavation of trenches for water supply lines shall be considered as full compensation for the work specified in this section and shall include constructing and removing of all temporary arrangements pumping and dewatering, removal of soft soil from bottom of trenches, removing the surface material and all incidentals to complete this work.

6.10 **PAYMENT**

Payment shall be made for this item of work at the unit rate quoted in the priced Bill of Quantities.

SECTION - 7 EARTH WORK FOR SEWERS

7.1 **DESCRIPTION**

Work under this section shall consist of furnishing all materials, equipment and labour for excavation, trenching and backfilling for sewers, drainage facilities, structures and all other appurtenances of sewage collection system, in accordance with drawings to proper line and grade refilling the trenches and dressing them to proper surface.

7.2 **CLEARING AND GRUBBING**

The sites of all excavations shall be cleared of all shrubs, plants, bushes, large roots, rubbish and other surface materials. All such materials shall be removed and disposed of in a manner, satisfactory to the Engineer. All trees and shrubbery, that are designated by the preserved in an approved manner.

7.3 **EXCAVATION**

7.3.1 **General**

The Contractor shall do all excavation of whatever substance encountered to the depth shown on the drawings or as otherwise specified. Excavation shall include without classification the removal and disposal of all material of whatever nature that would interfere with the proper construction and completion of the work and shall include the furnishing, placing and maintenance of supports for the sides of the excavations. The work shall also include all pumping, ditching, dewatering and other measures required for the removal and exclusion of water. During excavation, material suitable for backfilling shall be stock-piled in an orderly manner at a sufficient distance from the bank of the excavation to avoid overloading and to prevent sides from caving. Top soil should be stockpiled separately for subsequent reuse as necessary. All excavated material unsuitable or not required for backfilling shall be removed and disposed of at a location approved by the Engineer.

For contract purposes hereunder, the earth excavation work has been classified into two categories, earth excavation in trenches, and earth excavation for structures.

7.3.2 **Earth Excavation in Trenches**

Except as otherwise provided herein, excavation for a sewer line shall be open cut trenches with vertical side and not more than 150 feet of any trench in advance of the end of the built sewer shall be opened at any time and unless written permission to the Contractor is given by the Engineer. The trench shall be excavated to its full depth for a distance permitted for the sewer to be laid. Trenches for sewer-lines and appurtenances shall be to the lines and grades shown on the drawing or as ordered in writing by the Engineer as necessary for the proper completion of the work. Bell holes and depressions for joints shall be dug after the trench bottom has been graded. The pipe except for joints shall rest on the prepared bottom for its full length. Bell holes and depressions shall be only of such length, depth and width as required for properly making the particular type of joint. Stones shall be removed to avoid point bearing.

Where the bottom of the excavation is in material which in the judgment of the Engineer by reason of its hardness cannot be excavated to provide a uniform bearing for the pipe, said material shall be removed to minimum of 6 inches below the grade of the bottom of the pipe, and the trench backfilled to the required pipe sub-grade with river sand or other material acceptable to the required depth with concrete grade if so ordered. In no case material removed from such excavation shall be used as backfill material unless approved by the Engineer. All instruction shall be in writing by the Engineer.

7.3.3 **Earth Excavation for Structures**

All earth excavation under this contract, which is not included under the classification of " Earth Excavation in Trenches " shall be classified and paid for as earth excavation for structures.

The Contractor shall provide adequate timbering or shoring for excavations. Should the sides and ends of any excavations give way the contractor shall, at no extra cost, remove all disturbed ground. Any excavation carried outside the limits shown or drawings and specified herein as the payment limits, shall not be treated as excavation and shall not be paid for.

When foundation level is reached, the Engineer representative will inspect the exposed ground and give directions as to what further excavation, if any, be considers necessary. The excavation should be done in such a manner, as to ensure that the work rests in a solid and perfectly clean foundations. If the Contractor allows any portion of such foundations to deteriorate due to exposure, he shall make good the foundation to the satisfaction of the Engineer without extra cost.

7.3.4 **Alignment and Grade**

The sewers are to be laid to the alignment and gradient shown on the drawings, but subject to such modifications as shall be ordered by the Engineer from time to time to meet the requirements of the works. No deviations from the lines, depths of cutting or gradients of the sewers shown on the drawings and sections shall be permitted except by express directions in writing of the Engineer.

7.3.5 **Setting of Sight Rails**

The sewers shall be constructed and laid to a true grade and in straight liens between curves as shown on the plan. The sewer shall be laid and constructed to their proper levels with the aid of suitable boning rods and sight rails which shall be fixed according to the requirements of the Engineer at intervals not exceeding 10 feet and also by leveling along the invert with leveling instruments. The sight rails and boning rods shall be provided, fixed and maintained by the Contractor who shall also provide and maintain suitable leveling instruments and equipment and shall set the positions and levels of the sewers and other work according to the drawings and any instructions which he may receive from the Engineer. All sight rails and posts shall be well seasoned deodar timber or ample size and strength. The rails and boning rods shall be suitably and accurately planned and no warped or otherwise defective or damaged sight rails or boning rods shall be used. Sight rails shall be secured to the posts by strong steel clamps to the approval of the Engineer and in such a manner that they shall be fixed as immovable, in relation to the correct liens and levels. All boning rods and sight rails shall have the centre line accurately marked thereon by a fine saw cut and shall be painted black and white to the requirements of the Engineer. All boning rods shall suitably be showed with iron. At least four separate sight rails shaft always be maintained in correct level and alignment along the line of sewer at every place where construction work is proceeding

and the alignment and level of the sight rails shall be checked by the level and line at least twice every day to ensure that no disturbance or interference of the alignment and level have taken place. Whenever required the Contractor shall erect and maintain such additional sight rails as the Engineer shall direct. The Contractor shall, at all times, see that his workmen or other unauthorized persons are not allowed, accidentally or otherwise, to tamper or interfere with sight rails or other alignment or level marks.

All bends and curves shall be set out mathematically in a manner approved by the Engineer and the Contractor shall provide and maintain for the purpose such additional sight rail posts and other wrought and rough timber work, steel wire and other articles as the Engineer shall require from time to time.

7.3.6 **Sheeting and Bracing**

If ordinary open-cut excavation is not possible or advisable, sheeting and bracing shall be furnished and installed in excavations to prevent damage and delay to the work and to provide working conditions which are safe. The Contractor shall furnish and place all shoring, sheeting, walls braces, timbers and similar items necessary for the safety of work, the general public and adjacent property. Sheeting, shoring and wall bracing shall be removed as the work progresses and in such manner as to prevent damage to the finished work and adjacent structures and property. As soon as it is withdrawn all voids left by the sheeting and bracing shall be carefully filled with selected material and compacted. The Contractor shall be fully responsible for the safety of work in progress, for the finished work, the workmen, the public expenses, as part of the work under the excavation items and at no extra cost.

7.3.7 **Dewatering of Trenches**

As part of the work under the excavation items and at no extra cost, the Contractor shall build drains and do ditching, pumping, well-pointing, hailing and all other work necessary to keep the excavation clear of ground water, sewage and storm water during the progress of the work and until the finished work is safe from injury, the Contractor shall provide all necessary pumping equipment for the dewatering work, as well as operating personnel, maintenance, power etc. all at no extra cost. All water pumped or drained from the work shall be disposed of in a manner satisfactory to the Engineer. Necessary precautions against flooding shall be taken.

7.3.8 **Maintenance of Excavations**

All excavation made hereunder shall be properly maintained while these are open and exposed. Sufficient suitable barricades, warning lights, signs and similar items shall be provided by the Contractor. The Contractor shall be responsible for any personal injury or property damage due to his negligence.

7.3.9 **Protection of Existing Facilities**

The Contractor shall take special care of existing sub-surface facilities likely to be countered during the excavation for their protection, such as sewers, drain pipes water main conduits, electric cables, communication cables and the foundations of adjacent structures. The Contractor shall be responsible for any damage to any such facility and shall repair the same at his expense whether or not the facility has been shown on the drawing.

7.3.10 **Disposal of Surplus Excavated Material**

All surplus material excavated by the Contractor shall be disposed of at locations approved by the Engineer. The disposal of surplus material shall not interfere with other works and shall not damage or spoil other materials. When it is necessary to haul earth material over streets or pavements, the Contractor shall prevent such material from falling on the streets or pavements.

7.4 **BACKFILLING**

7.4.1 **General**

After the completion of sewer line, drainage facilities foundations, walls and other structures below the elevation of the final grade all voids shall be backfilled with suitable materials specified below.

7.4.2 **Backfilling for Structures**

Backfilling operations for structures shall be performed as part of the Contractor's work under the payment items for earth excavation and at no extra cost. Backfilling material for foundations, walls and other structures shall consist of excavated soil which is free from stones and hard clods not larger than 3 inches in any dimension, and also free from trash, lumber and other debris. Backfill material shall have enough moisture for proper compaction and shall be compacted in an approved manner to 90 percent of maximum density for cohesive soils and 95 percent of maximum density for cohesion less soils. Backfill shall not be placed against foundation walls earlier than 4 days after placing of concrete or brick masonry.

7.4.3 **Backfilling for Trenches**

After the sewers have been constructed and proved to be water tight as per direction of the Engineer the trench shall be backfilled. Utmost care shall be taken in doing this so that no damage shall be caused to the sewer and other underground utilities. After this has been laid the trench and other excavation shall be backfilled carefully in 6" layers with earth as approved by the Engineer, each layer being watered to assist in the compaction unless the Engineer shall otherwise direct.

7.5 **MAXIMUM DENSITY DETERMINATION FOR COMPACTED SOIL**

The maximum density of the soil shall be determined in accordance with the latest revision of " American Society for Testing Materials (ASTM) Standard D 1557 Density Relations of Soils, using 15 lbs. Rammer and 18 inches Drop".

7.5.1 **Testing Density of Soil**

The Engineer may make tests using the calibrated sand cone method/core cutter method to determine the density of soil in place in accordance with ASTM Designation D 2558, latest revision. If soil in place fails to meet the specified degree of

compaction the areas represented by the falling tests shall be re-excavated and compacted to the specified density in the manner directed by the Engineer at no extra cost.

7.5.2 **Top Soil**

Top soil which has been stockpiled during excavation shall be used for the top 6" of backfill, in locations as ordered by the Engineer. Top soil shall be saturated with water and after it has dried, shall be spread to the required final grade and of required density. The work shall be performed at no extra cost.

7.5.3 **Proximity to Buildings**

Where buildings in the opinion of the Engineer near excavation are likely to be affected, the Contractor shall provide proper shoring to protect such buildings in addition to timbering of trenches. The Contractor shall be required to leave timbering inside trenches if so required by the Engineer for protection of these buildings at no extra cost.

7.6 **LENGTH OF TRENCHES IN ADVANCE OF CONSTRUCTION**

Unless otherwise directed in writing by the Engineer of the work not more than 200 feet in advance of constructed or laid sewer shall be left open at any time. The trench shall, however, be excavated to full width to minimum length of 16 feet in advance of the constructed laid sewer unless otherwise directed by the Engineer.

7.7 **DISPOSAL OF FILTH AND GARBAGE**

No night soil filth and garbage met with during the excavation shall be allowed to be deposited on side of road/street so as to cause nuisance or obstruction to traffic. The same shall be disposed of by the Contractor to a place to the satisfaction of the Engineer.

7.8 **DISPOSAL OF SURPLUS EARTH**

The Contractor shall dispose of all surplus excavated materials not required to be used on the work. This shall include surplus earth after refilling and compaction.

7.9 **TUNNELLING**

7.9.1 **Formation of Soil**

Tunneling shall only be permitted in strong hard and homogeneous, clay formation which are not likely to collapse under normal working conditions. The work shall not be permitted in running sand. In weaker formation such as mixture of clay and sand which are liable to collapse when exposed to atmosphere. The roof shall be protected by adequate timbering and shoring of roof and the walls, irrespective of any type of alluvial strata. If the tunnel is subject to any sort of traffic, it shall be provided with adequate timbering and shoring for its roof and walls.

7.9.2 **Length of Tunnel**

Normally the length of tunnel without adequate support shall not exceed 3'. This length shall, however, may be exceeded under the directions of the Engineer, where depth of tunnel below ground level is considerable to avoid any danger of collapse. The tunnel, however, shall be driven in longer lengths up to 150 feet, if drive casing is provided as the tunnel is being excavated.

7.9.3 **Horizontal Boring Machines**

When considered necessary by the Engineer, horizontal boring machines shall be employed for crossing sewers underneath highways and canals. Whenever such machinery is used, drive casing of steel pipes shall be drive to avoid any collapse of the tunnel.

7.9.4 **Backfilling of Tunnels**

Tunnels shall be filled in with sand or selected material as directed by the Project Manager.

7.10 **MEASUREMENT**

Measurement shall be made for the actual quantity in 3' of excavated trenches. The maximum width of trenches allowed for payment will be as follows :-

- a) Trenches not exceeding 6 feet in depth 24" plus external diameter of the barrel for pipe sewers.
- b) Trenches exceeding 6 feet and not exceeding 12' in depth, 30" plus external diameter of the barrel for pipe sewers.
- c) Trenches exceeding 12' in depth, 36" plus external diameter of the barrel for pipe sewers.

7.11 **RATE**

The unit rate tendered in the priced Bill of Quantities for excavation and back filling of trenches for sewer lines, shall be the full compensation for the cost of materials, labour, equipment, tools and all incidentals necessary completely to execute this item of work strictly as per specifications laid down in this section.

7.12 **PAYMENT**

Payment shall be made at the unit rate quoted in the priced Bill of Quantities.

SECTION - 8 BEDDING

8.1 **GENERAL**

Wherever specifically called for by means of notes on the contract drawings or by written order of the Engineer the Contractor shall furnish and place sand or pea gravel bedding under water lines, sewer lines, drain pipes and other structures as a separate item of payment.

8.2 **SOURCE OF BEDDING MATERIAL**

Sand or pea gravel for bedding shall be from a source and of specifications approved by the Engineer.

8.3 **PURITY AND STACKING**

The sand and gravel shall be free from clay, salt, alkali, organic matter, shale, loam, soft flaky particles and other deleterious substance. It shall be stacked at the place designated by the Engineer and kept free from the admixture of deleterious materials mentioned herein.

8.4 **PLACING OF BEDDING MATERIAL**

The material for bedding shall be placed to the specified thickness and compacted by rammers of approved weight.

8.5 **MEASUREMENT**

The measurement shall be made by volume for the actual quantity of the work done and the unit of measurement shall be one cubic feet.

8.6 **PAYMENT**

Payment for this item of work shall be made for the actual quantity of work done as specified in this section, at the unit rate quoted in the priced Bill of Quantities.

SECTION - 9 DISMANTLING & RESTORATION OF PAVEMENT

9.1 **DESCRIPTION**

The work covered by this section of the specifications consists in furnishing all labour, equipment, appliances and materials and in performing all operations in connection with cutting and restoration of road/street surface and pavement, cut or damaged as a result of work accomplished under this contract, in strict accordance with this section of the Specifications and the applicable drawings, and to the satisfaction of the Engineer.

9.2 **CUTTING OF ROAD/STREET SURFACE AND PAVEMENT**

In cutting and breaking road or street surface and pavement, the contractor shall not use such equipment and appliances which shall damage the adjacent surface. Existing paved surface shall be cut back beyond the edges of the trenches to form neat square cuts. The dismantled materials shall be placed on one side of the trench for reuse after backfilling, for the restoration of the road surface. Not more than 500 feet of continuous road/street surface shall be cut or disrupted at a time for laying the drains. The Contractor shall take all safety measures against traffic hazards and shall provide proper diversion for the traffic where necessary. The diversion shall be indicated by suitable street signs 3 feet by 4 feet in size. During night enough red lights shall be provided to warn the traffic.

9.3 **CUTTING IN EXCESS OF THE WIDTH OF TRENCH**

The cutting of the road/street surfaces and pavement shall be limited to the width of the trench. Where the contractor has cut the road surface or pavement in excess of the width of the trench, he shall not be paid for the excess cutting and the excess cutting shall be restored by the contractor at his own expenses.

9.4 **RESTORATION OF ROADS/STREET SURFACE AND PAVEMENT**

After backfilling of trenches the cut road/street surface and pavement shall be restored as quickly as possible to original foundations and grade and line in such a manner as to acceptable surface for traffic. Intersections shall be restored within 24 hours after being cut.

SECTION - 10 MISCELLANEOUS WORK

10.1 **DESCRIPTION**

The work covered by this section of the specifications consists in furnishing all labour equipment, appliances and materials and in performing all operation in connection with providing water, sewerage and drainage and gas connections to the existing lines. This Section of the Specifications is intended to cover all miscellaneous items which are not specifically called for in other sections of these Specifications, Items shown or called for on the drawing, but not itemized herein, shall be furnished under the Conditions of this section and shall generally conform, as closely as possible to these Specifications unless otherwise directed by the Engineer.

10.2 **MATERIAL REQUIREMENTS**

10.2.1 **Structural Steel**

For screen, grating, & I beam steel shall be carbon grade 0ASTM A-36), minimum strength of which shall be 36,000 psi. Except where otherwise shown all structural steel shapes and sizes shall be shown on the Plans.

The bar steps in sewage lift station O/H, U/G Reservoir manholes shall be malleable iron steps (galvanized), designed with non-solid tread and shall comply with BS 1247/75. The steps shall be hot dipped galvanized with overall length, width, tread length and minimum weight of 10,6,5 inches and 4.6 lbs. respectively.

10.3 **CONSTRUCTION REQUIREMENTS**

10.3.1 **Fabrication of Screen**

Screen and gratings for sewage lift station shall be constructed in accordance with the details as shown on the Plans.

Metal shall be well formed to shape and size, with sharp line or angles. Shearing and punching shall leave clean, true lines and surfaces. Permanent connections shall be welded. The use of screws or bolts shall be avoided but where used, heads shall be counter sunk screwed on tight, and the threads nicked to prevent loosening. Necessary rabbits, lugs and brackets shall be provided so that work can be assembled in a neat and substantial manner. Thickness of metal and details of assembly and supports shall give ample strength and stiffness. All the work shall be installed in an approved and rigid manner, and where possible, shall be secured with galvanized bolts or welded where shown.

10.3.2 **Painting**

Screen surface shall receive one coat of rust inhibitive metal primer to red lead paint for which no separate payment shall be made to the Contractor.

10.3.3 **Welding**

Welding shall be continuous along entire line of Contract, except where spot welding is indicated on the drawings or is authorized by the Engineer. Exposed welds shall be ground smooth except otherwise directed by the Engineer.

10.3.4 **Bolting**

Bolting where permitted shall be done with proper size bolts. Nuts shall be drawn tight and threads nicked.

10.4 **MEASUREMENT**

Measurement for Screen will be made for the actual work executed at the unit rate entered in the Bill of Quantities. Bar steps shall be measured per unit acceptably placed in the wall completed and approved. All connections to the specified lines (i.e. water, sewerage and drainage) shall be Lump sum.

10.5 **RATE AND PAYMENT**

Payment shall be made at the unit rate stated in the Bill of Quantities. Such payment shall constitute full compensation for furnishing all materials equipment and labour including testing and all other incidentals necessary to complete the work according to the applicable drawings and directions of the Engineer.

SECTION - 11 WATER RETAINING STRUCTURE

11.1 **DESCRIPTION**

The work covered by this Section of specification & consist of Construction of Overhead, Underground Water Tanks and Swimming Pool.

11.2 **MATERIAL REQUIREMENTS**

All materials such as cement, sand, aggregate & steel etc. shall conform to the specifications given in respective Section (Material) or given elsewhere.

11.3 **CONSTRUCTION REQUIREMENTS**

The Contractor shall carry out the work according to design/drawing/instructions of Engineer Incharge. Work shall include the following:

1- Columns/pillar raised/constructed upto required height in RCC 1:1-1/2:3.

2- Bed and side walls of tanks shall be constructed in RCC 1:1-1/2:3 mixed with pudlo as per manufacturer's directions.

3- inside of the tank shall be finished with 1/2" thick terrazzo over 1/2" thick 1:2 cement sand mortar, ceramic tiles as specified on drawings.

4- Roof slab shall be in RCC 1:2:4 with manhole cover with frame and vent pipes.

5- In joint water stopper 9" wide will be used.

6- For pipes, Rising mains, delivery, overflow & washout, puddle collars of specified size will be fixed during pouring of side wall concrete.

7- Necessary gauge and float valve shall be provided.

8- Stairs shall be provided inside & outside the tanks as per plans.

9- Inside of the tank will be lime washed for dis-infection.

10- If any plaster is done that will be in cement sand mortar 1:3 with pudlo.

11- External sides of walls of underground water tank will be provided vertical DPC as per specifications in Section DPC.

11.4 **MEASUREMENT**

Measurement will be taken in capacity of water tank. For calculating capacity. Free board will not be accounted for i.e. height. From bottom to water level will be taken.

11.5 **RATE AND PAYMENT**

Rate shall include all material form work & labour etc. complete in all respect as per design / drawing / instructions of Engineer In charge.

Bill Of Quantities (BOQs) EXAMINATION HALL (Covered Area 11072 Sft)					
Civil Works		Unit	Quantity	Unit Rate	Amount
S.No.	Description			Rs.	Rs.
A	RCC & EARTH WORK				
1	Dismantling R.C.C. including separating reinforcement from concrete including stacking at site and disposing of unserviceable material complete and as per instructions of Engineer in charge.	Cft	9809.01155		
2	Dismantling Block masonry including disposing of surplus material and Providing & laying pre-cast solid blocks masonry using 6"x8"x12" size pre-cast blocks of min 1000 psi compressive strength set in cement mortar 1:5 in any floor superstructure including scaffolding, raking out joints & curing and plastering with 1/2" (13 mm) thick cement plaster 1:6 complete. complete and as per instructions of engineer in charge	Cft	387.975		
3	Clearing and grubbing the site by cutting, uprooting and removing all rubbish and shrubs including disposal to (outside limits) designated places.	Sft	2290.7535		
4	Providing and laying Ready mix Reinforced concrete 4000 Psi cylindrical strength using stationary or any other pumps, as in roof, slabs, walls, landings, plinth beams,rafts and bands etc as specified requiring steel shuttering etc complete & as per instructions of engineer in charge. Reinforcement to be measured and paid separately.	Cft	9291.24556		
5	Providing and laying deformed (minimum yield point 60,000 psi) reinforcement bars with & including the cost of straightening, cutting, bending, binding, placing in position in all kinds of RCC work in foundation, basement, plinth and any floor of building and as per direction of engineer in charge.	Kg	16857.9254		
6	Providing loose concrete near the Corroded Exposed Rebars and adjacent to the corroded area, wire brushing of rebars,applying zinc Rich on Rebars,nailling the treated surface by concrete nails if 8 BWG, applying SBR all around the surface, placing 20 BWG Expanded Metal and laying with installed nails and plastering with 1:3 cement sand Mortar mixed with plasticizer and finishing the surface to fine and level the surrounding surface.	Sft	948.3264		

7	Rehabilitation of Columns By cutting the damaged surface and brushing of existing steel bars to remove the rust, and coating the bars with zinc rich primer to protect from rust, add new bars where required by drilling holes and filling the holes with chemical grout and concreting the column with 5000PSI Concrete as per drawings, site requirement and direction of engineer incharge.	Sft	722.4		
8	Rehabilitation of Plinth Beams by Cutting the damaged surface and brushing of existing steel bars to remove the rust, and coating the bars with zinc rich primer, excavate the area to add lean 1:2:4 below plinth beam, add new bars and concreting the beam with 5000 PSI concrete as per drawings, site requirement and direction of engineer incharge.	Rft	42		
B	Cement Plaster				
1	1/2" (13 mm) thick cement plaster 1:4 on walls and columns etc. making edges, comers, and curing etc., complete. (Internal Plaster)	Sft	927.15		
2	3/8" (10 mm) thick cement plaster 1:4 including making edges, corners, and curing etc. (Ceiling Plaster)	Sft	11972.5053		
3	3/4" (19 mm) thick cement plaster 1:4 including making edges, corners, and curing etc. (External Plaster)	Sft	4347.7938		
C	Paint				
1	Removal of old Paint and Painting three coats with weather shield paint (Each coat will be applied after 5 Days)	Sft	5296.1202		
2	Removal of old Paint and Distempering three coats with poly vinyl distemper (Each coat will be applied after 5 Days)	Sft	11972.5053		
3	Removal of old Paint and Preparing the surface and painting three coats with matt finish (Each coat will be applied after 5 Days)	Sft	1843.4514		
4	Providing and fixing angle section of L 6"x6"x1/4" for supporting of Existing Beam and making its connections with Rawal Bolts and using Welding work to attach Angle iron with another Angle iron	Each	51		
D	Flooring				
1	Providing & laying floor of mosaic marble chips tile 1" (25mm) thick of approved quality and shade laid in white cement and pigment over 3/4" (20mm) thick bedding in cement sand mortar 1:2 including finishing and polishing complete as per Approval of Client	Sft	11509.8132		
2	Laying floor of approved with glazed tiles 1/4" thick dado of approved color & size jointing in white cement and laid over 1:2 cement sand mortar 3/4" thick including grouting with matching color and finishing	Sft	675		

E	ROOF TREATMENT				
1	Providing water proofing roof treatment by Dismantling old Screeding and providing hot bitumen layer with Insulation Board and sand as slope after screeding provided for water drainage.	Sft	11963.0334		
2	Providing and laying 3" thick topping of cement concrete (1:2:4) including Surface finishing and dividing into panels:	Sft	11963.0334		
F	DOOR & WINDOWS				
1	Providing and fixing Aluminium windows & Ventilator box section including the cost of glass pan, aluminium fittings, with all accessories cutting hole etc. and making good damages to walls etc. complete as required in any floor as per direction of engineer-in-charge	Sft	558		
2	First Class deodar wood wrought joinery in doors and windows etc. panelled or panelled or glazed or fully glazed fixed in position including chowkhat, holdfast, hinges, tower bolt rubber stop cleats/G I clamp, handles and chord with hooks etc. complete (excluding sliding bolts or lock).	Sft	460		
3	Supplying & fixing in position iron/steel grill of 3/4" x 1/4" size flat iron of approved design including painting 3 coats etc. complete (weight not to be less than 3.7 Lbs./Sq . Foot of finished grill)	Sft	558		
G	PLINTH PROTECTION				
1	Excavation for Plinth Protection about 1.5ft wide & 1.5ft Deep and Providing CC 1:4:8 Below Foundation with 6" Thick Block Masonry and laying 50mm Pavers, 2" Thick Sand Cushion, 4" Thk Gravel Layer and 4" Thk 1:3:6 as Per Direction of Engineer-in-Charge.	Rft	482.1507		
H	PLUMBING				
1	Rehabilitation of Internal Plumbing by Repair Or Dismantling & providing new Plumbing Fixtures Where required.				
a	25mm 1" --PPRC pipe PN-20	Rft	66		
b	50mm 2" --PPRC pipe PN-20	Rft	20		
c	1 inches (25mm) dia Ball Valve	Each	2		
d	1-1/2 inches (40mm) dia Ball Valve	Each	3		
e	2 inches (50mm) dia Ball Valve	Each	2		
g	4 inches (100 mm) dia pipe. --(U.P.V.C) "E" class	Rft	40		
2	Supplying & fixing Fiber glass tank of approved quality and design and wall thickness as specified including cost of nuts, bolts and fixing in plat form of cement concrete 1:3:6 and making connection for inlet, outlet and over flow pipes etc. complete 350 gallons tank with wall thickness 4.0mm	Each	2		

3	Providing and fixing squatting type white glazed earthen ware W.C pan with front flush inlet & complete with including the cost of flushing cistern with internal fitting and flush pipe with bend and requisite number of holes in walls plinth & floor for pipe connection & making good in cement concrete 1:2:4 Far.(23 inch	Each	2		
4	Providing and fixing European type white glazed earthen ware wash down W.C. pan complete with & including the cost of white / black plastic seat (Best quality) and lid with C.P. brass hinges best quality and buffers 3 gallons white glazed earthen ware low level flushing cistem with siphon fitting 1½ " dia white porcelain enameled flush bend dia and making requisite number of holes in walls , plinth & floor for pipe connection & making good in cement concrete 1:2:4	Each	2		
5	Providing and fixing 24x18" lavatory basin in white glazed earthen ware complete with & including the cost of W.I. or C.I. cantilever bracket 6 inches built into wall, painted white in two coats after a primary coat of red lead paint, a pair of ½" dia chrome plated pillar taps, 1-1/2" rubber plug & chrome plated brass chain 1-1/4" dia malleable iron or C.P. brass traps malleable iron or brass unions and making requisite number of holes in walls, plinth & floor for pipe connection & making good in cement concrete 1:2:4	Each	2		
6	Supplying & Fixing wash basin mixture of superior quality with C.P head 1/2" dia with swan type pillar cock of Superior quality single c.p. head 1/2" dia. and Providing & fixing in position nylon connection complete with 1/2" dia brass stop cock with pair of brass nuts and lining joints to nylon connection .	Each	2		
7	Upvc rain water down pipe 4"	Rft	75		
I	MISCELLANEOUS				
1	Installation of ON Grid Solar System 50 KW (Grade- I)	KW	1		
2	Providing & Fixing appropriate numbers of Air Conditioners of 4 Ton	Ton	8		
3	Providing "Expansion Joint" in concrete work of 9" wide corrugated PVC waterstop (with bulb) i.e soldering cost of material and labour etc complete.	Rft	68		
J	SEWERAGE				
1	Rehabilitation of External Sewerage by Repair Or Dismantling R.C.C / pipe & providing and laying New Manhole or Gully Trap where required.	Rft	532.1507		

K	ELECTRICAL				
a	PVC Conduit:-				
1	Providing & laying 20mm dia PVC Conduit recessed / surface (For light & Fan point wiring)	Rft	1400		
2	Providing & laying 25mm dia PVC Conduit recessed / surface (For power plug & circuit wiring)	Rft	2800		
b	GI Conduit:-				
1	Providing & fixing 12mm dia GI Conduit (For light & Fan extension rod)	Rft	350		
c	Wiring:-				
1	Providing & laying 1.5sq mm PVC wire single core stranded copper conductor in given PVC Conduit recessed / surface (For light & Fan point wiring)	Rft	17500		
2	Providing & laying 2.5sq mm PVC wire single core stranded copper conductor in given PVC Conduit recessed / surface (For power plug, circuit and highbay light wiring)	Rft	5000		
3	Providing & laying 4sq mm PVC wire single core stranded copper conductor in given PVC Conduit recessed / surface (For industrial socket wiring)	Rft	2200		
4	Providing & laying 6sq mm PVC wire single core stranded copper conductor in given PVC Conduit recessed / surface (For SPlit AC wiring)	Rft	150		
5	Providing & laying 25sq mm PVC wire single core stranded copper conductor in given PVC Conduit recessed / surface (For DB wiring)	Rft	700		
d	Fitting & Fixtures:-				
1	Providing & fixing PVC box recessed / surface size 3"x3" (For gang switch and socket)	Nos	60		
2	Providing & fixing PVC box recessed / surface size 6"x3" (For gang switch and socket)	Nos	12		
3	Providing & fixing PVC box recessed / surface size 8"x6" (For gang switch and socket)	Nos	15		
4	Providing & fixing 4 gang switch on given junction box good quality	Nos	8		
5	Providing & fixing 6 gang switch on given junction box good quality	Nos	12		
6	Providing & fixing 10A three pin switch and socket on given junction box good quality	Nos	22		
7	Providing & fixing 15A three pin switch and socket on given junction box good quality	Nos	16		
8	Providing & fixing 20A industrial socket on given junction box good quality	Nos	15		
9	Providing & fixing fan clamp box good quality	Nos	64		

10	Providing & fixing ceiling fan 56" sweep good quality	Nos	64		
11	Providing & fixing Industrial Exhaust Fan 36" dia	Nos			
12	Providing & fixing fan dimmer good quality	Nos	64		
13	Providing and fixing 18" sweep metallic body exhaust fan complete with blades, motor, shutter etc including making hole in the wall & connection with 14.0076 flexible wire complete as required.	Nos	9		
14	Providing & fixing PVC batten holder good quality	Nos	107		
15	Providing & fixing PVC ceiling rose good quality	Nos	9		
16	Providing & fixing LED bulb 30w good quality	Nos	107		
17	Providing & fixing LED down light 9w good quality	Nos	40		
18	Providing & fixing LED High bay light 60-100w good quality	Nos	18		
e	CCTV Works				
1	providing and Installation of CCTV System with Complete Accessories	Rft	11500		
f	Distribution Board:-				
1	Providing & Fixing, testing, commissioning cubical type metal sheet distribution board flush / surface type with locking arrangement duly powder coated paint including all fastening material including wiring with suitable gauge PVC wire complete in all respect.	Sft	6		
g	Circuit Breakers:-				
1	Providing & fixing 10A to 32A SP MCB circuit breaker in given DB Terasaki or Equivalent	Nos	90		
2	Providing & fixing 20A to 32A DP MCCB circuit breaker in given DB Terasaki or Equivalent	Nos	8		
3	Providing & fixing 100A TP MCCB circuit breaker in given DB Terasaki or Equivalent	Nos	4		
4	Providing & fixing 200A TP MCCB circuit breaker in given DB Terasaki or Equivalent	Nos	1		
5	Providing & fixing pilot lamp in given DB good quality	Nos	9		
6	Providing & fixing Ampere meter in given DB good quality	Nos	2		
7	Providing & fixing Volt meter in given DB good quality	Nos	2		
h	Earthing System:-				
1	Providing and fixing Earthing set with 2'x2'x1/8" copper plate buried in the ground at a depth of 12 feet or less if water comes out from the ground level (salt & charcoal, or earthing chemical powder) etc. making the pit 12 feet deep by excavation of all type of soil (except soft or hard rock) including fixing of 2x8 SWG copper wire in 1/2" dia GI conduit complete in all respect as required.	Job	2		

2	Providing & fixing earth connecting strip size 150mmx20mmx6mm as required.	Each	4		
i	Cable Work:-				
1	P/Laying (Main or Sub Main) Pvc insulated / Pvc sheathed with size 4 core 95sq mm ug cable copper conductor (From Supply Point to M.DB)	Rft	100		
L	FURNITURE				
1	Examination Hall Seats Good Quality	Nos	220		
	GRAND TOTAL				

Bill Of Quantities (BOQs) Admin Block, Medical Center, Parade Ground, Sports Complex and Swimming Pool

Civil Works		Unit	Quantity	Unit Rate	Amount
S.No.	Description			Rs.	Rs.
A	RCC & EARTH WORK				
1	Dismantling Block masonry including disposing of surplus material and Providing & laying pre-cast solid blocks masonry using 6"x8"x12" size pre-cast blocks of min 1000 psi compressive strength set in cement mortar 1:5 in any floor superstructure including scaffolding, raking out joints & curing and plastering with 1/2" (13 mm) thick cement plaster 1:6 complete. complete and as per instructions of engineer in charge	Cft	1460		
2	Clearing and grubbing the site by cutting, uprooting and removing all rubbish and shrubs including disposal to (outside limits) designated places.	Sft	9429.75		
3	Providing loose concrete near the Corroded Exposed Rebars and adjacent to the corroded area, wire brushing of rebars, applying zinc Rich on Rebars, nailing the treated surface by concrete nails if 8 BWG, applying SBR all around the surface, placing 20 BWG Expanded Metal and laying with installed nails and plastering with 1:3 cement sand Mortar mixed with plasticizer and finishing the surface to fine and level the surrounding surface.	Sft	953.0625		
4	Rehabilitation of Columns By cutting the damaged surface and brushing of existing steel bars to remove the rust, and coating the bars with zinc rich primer to protect from rust, add new bars where required by drilling holes and filling the holes with chemical grout and concreting the column with 5000PSI Concrete as per drawings, site requirement and direction of engineer incharge.	Sft	69.5625		
B	Cement Plaster				
1	3/4" (19 mm) thick cement plaster 1:4 including making edges, corners, and curing etc. (External Plaster)	Sft	1200		
C	Paint				

1	Removal of old Paint and Painting three coats with weather shield paint (Each coat will be applied after 5 Days)	Sft	20		
2	Removal of old Paint and Distempering three coats with poly vinyl distemper (Each coat will be applied after 5 Days)	Sft	97.9125		
3	Removal of old Paint and Preparing the surface and painting three coats with matt finish (Each coat will be applied after 5 Days)	Sft	247.5375		
D	Flooring				
1	Providing & laying floor of mosaic marble chips tile 1" (25mm) thick of approved quality and shade laid in white cement and pigment over 3/4" (20mm) thick bedding in cement sand mortar 1:2 including finishing and polishing complete as per Approval of Client	Sft	4451.25		
2	Laying Verona marble flooring Size 24"x12"x1"/12"x12"x1" fine dressed on the surface without winding set in lime mortar 1:2 including rubbing and polishing of the joints b) 1" thick marble	Sft	2806		
3	Laying floor of approved with glazed tiles 1/4" thick dado of approved color & size jointing in white cement and laid over 1:2 cement sand mortar 3/4" thick including grouting with matching color and finishing	Sft	1301.75		
4	P/F Granite Strips (5"x1"x1") thick fixed over stair steps of required width set in cement sand mortar 1:2 in gray cement 1"thick in/c washing and filling etc complete.	Sft	612		
5	Providing & Laying Full Body Porcelain Tile in Flooring or Facing of Approved Design Set in Gry Cement Motor 1:2 or of 3/4" Thickness 1/C Washing & Joints With White Cement Slurry Using Colour Pigment for matching complete as per Spacification 16"x16"x5/16" thick flooring	Sft	6696.5814		
6	Providing and laying, CC Paving stone, 50 mm thick in natural colour, as in floors, ramps etc, any Reference and any shape, are fixed using 1:4 motar 3/4" thick and slurry of cement as the practice adopted in tiles ,granite or marble as per drawing and instruction engineer in charge.	Sft	2670		
7	Stone cladding of required size on wall facing of approved design shape and pattern set in cement sand mortar ratio 1:2 in gray cement 3/4" thick in/c washing of joints with net white cement salary and pigment in desire shape in/c cutting and dressing the stone tile to proper profile in/c labour etc complete as per specification as directed by the Engineer / Incharge.	Sft	1920		
E	ROOF TREATMENT				

1	Providing water proofing roof treatment by Dismantling old Screeding and providing hot bitumen layer with Insulation Board and sand as slope after screeding provided for water drainage.	Sft	45710.5814		
2	Providing and laying 3" thick topping of cement concrete (1:2:4) including Surface finishing and dividiing into panels:	Sft	45710.5814		
F	DOOR & WINDOWS				
1	Providing and fixing fully glazed aluminium Sliding windows & Ventilator box section including the cost of glass pan, aluminium fittings, with all accessories cutting hole etc. and making good damages to walls etc. complete as required in any floor as per direction of engineer-in-charge	Sft	20		
2	First class deodar wood wrought joinery in doors and windows etc. panelled or glazed or fully glazed fixed in position including chowkhat, holdfast, hinges, tower bolt rubber stop cleats/G I clamp, handles and chord with hooks etc. complete (excluding sliding bolts or lock).	Sft	124		
3	Supplying & fixing in position iron/steel grill of 3/4" x 1/4" size flat iron of approved design including painting 3 coats etc. complete (weight not to be less than 3.7 Lbs./Sq . Foot of finished grill)	Sft	24		
G	PLINTH PROTECTION				
1	Excavation for Plinth Protection about 1.5ft wide & 1.5ft Deep and Providing CC 1:4:8 Below Foundation with 6" Thick Block Masonry and laying 50mm Pavers, 2" Thick Sand Cushion, 4" Thk Gravel Layer and 4" Thk 1:3:6 as Per Direction of Engineer-in-Charge.	Rft	1957.95		
H	PLUMBING				
1	Rehabilitation of Internal Plumbing by Repair Or Dismantling & providing new Plumbing Fixtures Where required.				
a	25mm 1" --PPRC pipe PN-20	Rft	110		
b	50mm 2" --PPRC pipe PN-20	Rft	70		
c	1 inches (25mm) dia Ball Valve	Each	9		
d	1-1/2 inches (40mm) dia Ball Valve	Each	8		
e	2 inches (50mm) dia Ball Valve	Each	5		
g	4 inches (100 mm) dia pipe. --(U.P.V.C) "E" class	Rft	60		
2	Supplying & fixing Fiber glass tank of approved quality and design and wall thickness as specified including cost of nuts, bolts and fixing in plat form of cement concrete 1:3:6 and making connection for inlet, outlet and over flow pipes etc. complete 350 gallons tank with wall thickness 4.0mm	Each	3		

3	Providing and fixing squatting type white glazed earthen ware W.C pan with front flush inlet & complete with including the cost of flushing cistern with internal fitting and flush pipe with bend and requisite number of holes in walls plinth & floor for pipe connection & making good in cement concrete 1:2:4 Far.(23 inch	Each	9		
4	Providing and fixing 24x18" lavatory basin in white glazed earthen ware complete with & including the cost of W.I. or C.I. cantilever bracket 6 inches built into wall, painted white in two coats after a primary coat of red lead paint, a pair of ½" dia chrome plated pillar taps, 1-1/2" rubber plug & chrome plated brass chain 1-1/4" dia malleable iron or C.P. brass traps malleable iron or brass unions and making requisite number of holes in walls, plinth & floor for pipe connection & making good in cement concrete 1:2:4	Each	9		
5	Supplying & Fixing wash basin mixture of superior quality with C.P head 1/2" dia with swan type pillar cock of Superior quality single c.p. head 1/2" dia. and Providing & fixing in position nylon connection complete with 1/2" dia brass stop cock with pair of brass nuts and lining joints to nylon connection .	Each	9		
6	Providing and fixing flat black lipped front urinal basin (of not less than 17 " in height) of white glazed earthen ware complete with & including the cost of ½ " dia gun metal gate valve with standard flush pipe , waste pipe (enameled iron) complete with fitting and making requisite number of holes in walls , plinth & floor for pipe connection & making good in cement concrete 1:2:4 . (Standard pattern)	Each	5		
7	Upvc rain water down pipe 4"	Rft	320		
I	MISCELLANEOUS				
1	2" Thick Asphalt Concrete Wearing Course Mix Laying mechanically to proper Asphalt Concrete incharge rolling and finishing to design Proper grade line level and comber etc	Sft	161900		
2	Providing & Fixing appropriate numbers of Air Conditioners of 4 Ton	Ton	2		
3	making and fixing fiber glass sun shade standard size 3mm sheet (02 layer) molded in panel in/c M.S Pipe 6" dia 20' height at 20' center fixing C.C foundation with M.S Square pipe 1-1/2" x 1-1/2" double kanchi around from with internal M.S Square pipe 2x2 center to center in/c welding assembling etc complete in all respect	Each	2400		
4	Deodar wood counter including shutters and shelves complete with iron fitting.	Sft	692		

5	Providing "Expansiomn Joint" in concrete work of 9" wide corugated PVC waterstop (with bulb) i.c soldering cost of material and labour etc complete.	Rft	805		
J	SEWERAGE				
1	Rehabilitation of External Sewerage by Repair Or Dismantling R.C.C / pipe & providing and laying New Manhole or Gully Trap where required.	Rft	1793.95		
2	Supplying and fixing Centrifugal Pumping set complete with AC, electric motor driven, 400 volts, 3 phase, 50 cycles, 1 hp, mounted on a common channel base, total head 25/30 M	Each	1		
K	ELECTRICAL				
a	PVC Conduit:-				
1	Providing & laying 20mm dia PVC Conduit recessed / surface (For light & Fan point wiring)	Rft	40		
2	Providing & laying 25mm dia PVC Conduit recessed / surface (For power plug & circuit wiring)	Rft	15		
c	Wiring:-				
3	Providing & laying 1.5sq mm PVC wire single core stranded copper conductor in given PVC Conduit recessed / surface (For light & Fan point wiring)	Rft	100		
4	Providing & laying 2.5sq mm PVC wire single core stranded copper conductor in given PVC Conduit recessed / surface (For power plug, circuit and highbay light wiring)	Rft	40		
d	Fitting & Fixtures:-				
1	Providing & fixing PVC box recessed / surface size 3"x3" (For gang switch and socket)	Nos	2		
2	Providing & fixing 4 gang switch on given junction box good quality	Nos	1		
3	Providing & fixing 10A three pin switch and socket on given junction box good quality	Nos	1		
4	Providing & fixing fan clamp box good quality	Nos	1		
5	Providing & fixing ceiling fan 56" sweep good quality	Nos	1		
6	Providing & fixing fan dimmer good quality	Nos	1		
7	Providing & fixing PVC batten holder good quality	Nos	4		
8	Providing & fixing LED bulb 30w good quality	Nos	29		
9	Distribution Board:-				
10	Providing & Fixing, testing,commissioning cubical type metal sheet distribution board flush / surface type with locking arrangement duly powder quoted paint including all fastening material including wiring with suitable gauge PVC wire complete in all respect.	Sft	4		
g	Circuit Breakers:-				

1	Providing & fixing 10A to 32A SP MCB circuit breaker in given DB Terasaki or Equalent	Nos	38		
2	Providing & fixing 20A to 32A DP MCCB circuit breaker in given DB Terasaki or Equalent	Nos	2		
3	Providing & fixing 100A TP MCCB circuit breaker in given DB Terasaki or Equalent	Nos	1		
4	Providing & fixing 200A TP MCCB circuit breaker in given DB Terasaki or Equalent	Nos	1		
5	Providing & fixing pilot lamp in given DB good quality	Nos	3		
6	Providing & fixing Ampere meter in given DB good quality	Nos	1		
7	Providing & fixing Volt meter in given DB good quality	Nos	1		
GRAND TOTAL					
FURNITURE (ADMIN BLOCK)					
S.No	Description	Unit	Quantity	Unit Rate	Amount
1	Chart Table	Nos	80		
2	Table	Nos	2		
Grand Total					
FURNITURE (MEDICAL CENTER)					
S.No	Description	Unit	Quantity	Unit Rate	Amount
1	Clinical Couch	Nos	6		
2	Examination Trolley	Nos	6		
3	Bed	Nos	15		
4	Sofa Set	Nos	25		
5	Chairs	Nos	25		
6	Staff Table	Nos	5		
7	Office Table	Nos	4		
8	Bed, Patient, Electric	Nos	2		
9	Cabinet (Fixed/ Display Cabinet)	Nos	4		
10	Wheel Chair	Nos	4		
11	Workstation	Nos	2		
12	Waiting Chairs	Nos	14		
13	Ward Screen	Nos	15		
Grand Total					

Past Experience / Contracts

Contracts over *[insert amount]* during the last three years:

Procuring Agency	Value	Year	Goods/Services Supplied	Country of Destination

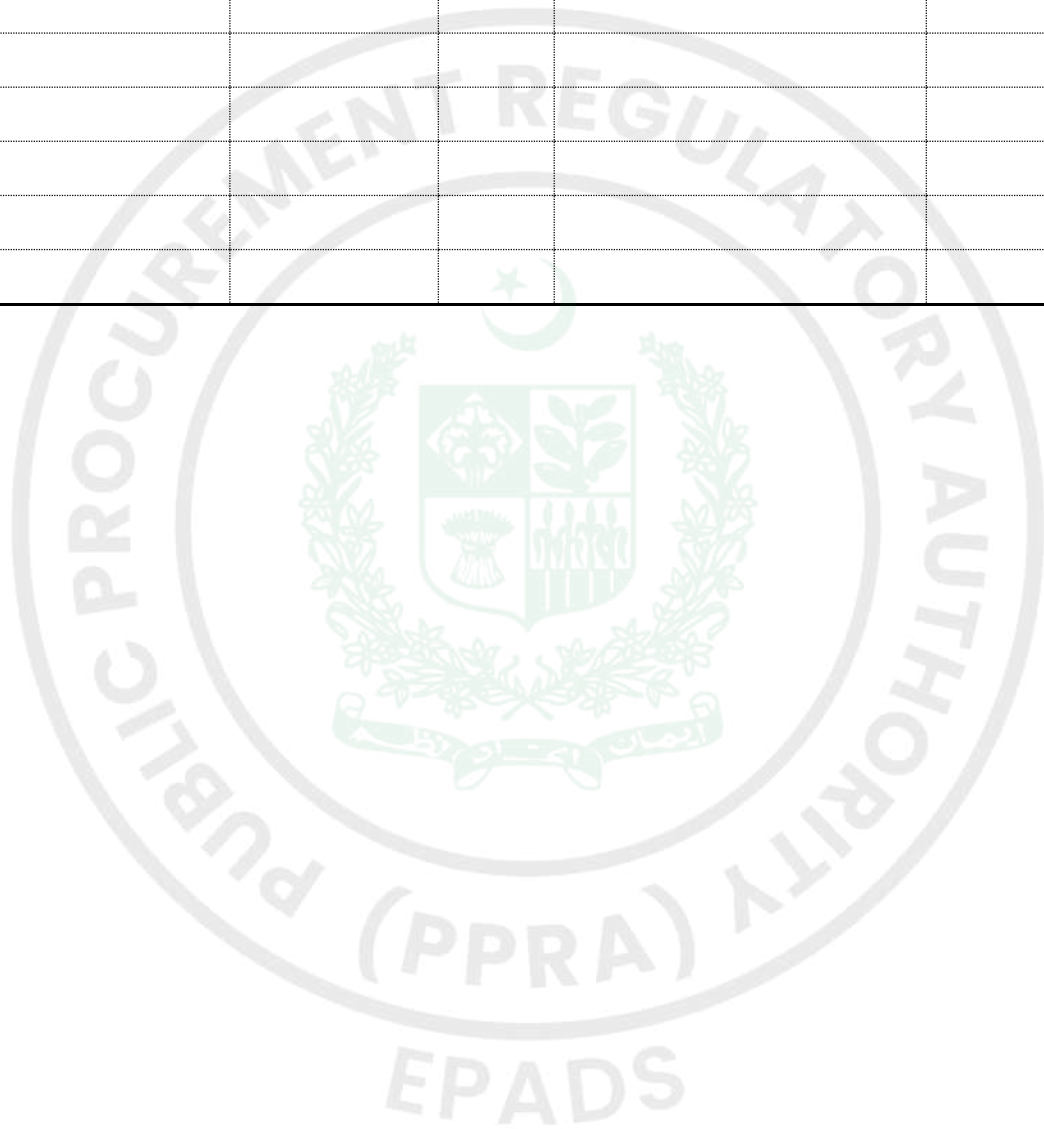

Historical Contract Non-Performance, and Pending Litigation and Litigation History

[The following table shall be filled in for the Applicant and for each member of a Joint Venture]

Applicant's Name: *[insert full name]*

Date: *[insert day, month, year]*

Joint Venture Member Name: *[insert full name]*

IFP No. and title: *[insert IFP number and title]*

Page *[insert page number]* of *[insert total number]* pages

<input type="checkbox"/> Not debarred due to deviation from commitment of Bid Securing Declaration- <input type="checkbox"/> Not debarred due to non-performance			
Year	Non-performed portion of contract	Contract Identification	Total Contract Amount (current value, currency, exchange rate and PKR equivalent)
<i>[insert year]</i>	<i>[insert amount and percentage]</i>	Contract Identification: <i>[indicate complete contract name/ number, and any other identification]</i> Name of Procuring Agency: <i>[insert full name]</i> Address of Procuring Agency: <i>[insert street/city/country]</i> Reason(s) for nonperformance: <i>[indicate main reason(s)]</i>	<i>[insert amount]</i>
Pending Litigation, in accordance with Section III, Qualification Criteria and Requirements			
<input type="checkbox"/> Pending litigation in accordance with Section III, Qualification Criteria and Requirements, Sub-Factor 2.3 as indicated below.			
Year of dispute	Amount in dispute (currency)	Contract Identification	Total Contract Amount (currency), US\$ PKR Equivalent (exchange rate)

<i>[insert year]</i>	<i>[insert amount]</i>	Contract Identification: [indicate complete contract name, number, and any other identification] Name of Procuring Agency: <i>[insert full name]</i> Address of Procuring Agency: <i>[insert street/city/country]</i> Matter in dispute: <i>[indicate main issues in dispute]</i> Party who initiated the dispute: <i>[indicate "Procuring Agency" or "Supplier"]</i> Status of dispute: <i>[Indicate if it is being treated by the Adjudicator, under Arbitration or being dealt with by the Judiciary]</i>	<i>[insert amount]</i>
<input type="checkbox"/> No consistent history of court/arbitral award decisions in accordance with Section III, Qualification Criteria and Requirements, Sub-Factor 2.4. <input type="checkbox"/> Consistent history of court/arbitral award decisions in accordance with Section III, Qualification Criteria and Requirements, Sub-Factor 2.4 as indicated below.			
Year of award	Outcome as percentage of Net Worth	Contract Identification	Total Contract Amount (currency), PKR Equivalent (exchange rate)
<i>[insert year]</i>	<i>[insert percentage]</i>	Contract Identification: [indicate complete contract name, number, and any other identification] Name of Procuring Agency: <i>[insert full name]</i> Address of Procuring Agency: <i>[insert street/city/country]</i> Matter in dispute: <i>[indicate main issues in dispute]</i> Party who initiated the dispute: <i>[indicate "Procuring Agency" or "Supplier"]</i> Court/ arbitral award decision: <i>[Indicate if the award decision was against the Applicant or any member of a joint venture.]y]</i>	<i>[insert amount]</i>

Current Contract Commitments / Contracts in Progress Form

1. Name of Contract(s)
2. Procuring Agency Contact Information [insert address, telephone, fax, e-mail address]
3. Value of outstanding contracts [current PKR equivalent]
4. Estimated Delivery Date
5. Average monthly invoices over the last six months (PKR/mon.)

Financial Situation and Performance

[The following table shall be filled in for the Applicant and for each member of a Joint Venture]

Applicant's Name: *[insert full name]*

Date: *[insert day, month, year]*

Joint Venture Member Name: *[insert full name]*

IFP No. and title: *[insert IFP number and title]*

Page *[insert page number]* of *[insert total number]* pages

1. Financial data

Type of Financial information in (currency)	Historic information for previous <i>[insert number]</i> years, <i>[insert in words]</i> (amount in currency, currency, exchange rate*, PKR equivalent)				
	Year 1	Year 2	Year 3		
Statement of Financial Position (Information from Balance Sheet)					
Total Assets (TA)					
Total Liabilities (TL)					
Total Equity/Net Worth (NW)					
Current Assets (CA)					
Current Liabilities (CL)					
Working Capital (WC)					
Information from Income Statement					
Total Revenue (TR)					
Profits Before Taxes (PBT)					
Cash Flow Information					
Cash Flow from Operating Activities					

* Refer ITA 14 for the exchange rate

3. Financial documents

The Applicant and in case of JV, members of JV shall provide copies of financial statements for *[number]* years pursuant Section III, Qualifications Criteria and Requirements. The financial statements shall:

- (a) reflect the financial situation of the Applicant or in case of JV member, and not an affiliated entity (such as parent company or group member).
 - (b) be independently audited or certified in accordance with local legislation.
 - (c) be complete, including all notes to the financial statements.
 - (d) correspond to accounting periods already completed and audited.
- Attached are copies of financial statements¹ for the *[number]* years required above; and complying with the requirements.

¹ If the most recent set of financial statements is for a period earlier than 12 months from the date of Application, the reason for this should be justified.

Average Annual Turnover (Annual Sales Value)

[The following table shall be filled in for the Applicant and for each member of a Joint Venture]

Applicant's Name: *[insert full name]*

Date: *[insert day, month, year]*

Joint Venture Member Name: *[insert full name]*

IFP No. and title: *[insert IFP number and title]*

Page *[insert page number]* of *[insert total number]* pages

Annual Turnover Data			
Year	Amount Currency	Exchange rate* (If applicable)	PKR equivalent
<i>[indicate calendar year]</i>	<i>[insert amount and indicate currency]</i>		
		Average Annual Turnover **	

* Refer ITA for date and source of exchange rate.

** Total PKR equivalent for all years divided by the total number of years. See Section III, Qualification Criteria and Requirements, ITA.